



General Catalogue

Vogl Deckensysteme

Ceiling Diversity in Form, Colour and Performance

2015



Vogl Deckensysteme GmbH

Industriestrasse 10
D-91448 Emskirchen

Phone +49 (0) 9104 - 825 - 0
Fax +49 (0) 9104 - 825 - 250

info@vogl-ceilingystems.de
www.vogl-ceilingystems.com

Subject to technical changes. Consumption, quantity and design details are based on empirical values. The details contained in this text correspond to the current state of technology. Any relevant valid building technology regulations, standards and guidelines must be observed in addition to our processing instructions. All rights reserved. Reprints as well as electronic reproduction, even extracts, require the express approval of Vogl Deckensysteme GmbH, Industriestrasse 10, 91448 Emskirchen, Germany. 01/15

Chapter Overview

Page

About Us	05
Product Range	13
Your Contact Partners	14
Framework	15
Acoustic Design Ceilings	26
Cooling and Heating Ceilings	31
Ceiling Tiles	36
Acoustic Plaster Ceilings	40
Acoustic Floating Ceilings	41
Moulded Components	42
3D Design	49
Integrated Ceiling Components	50
Stretch Ceilings.....	53
Working Methods	54
Services	58
Acoustic Design Ceilings	59
VoglFuge®	59
Visible Chamfer.....	71
GSG4 Joint.....	79
Compound Seam	91
Ball-impact Resistant Ceiling	101
Ceiling Tiles	109
Acoustic Plaster Ceilings	117
VoglToptec®	117
Cooling and Heating Ceilings	129
VoglThermotop®	129
Moulded Components, 3D Design	141
Moulded Components	141
3D Design	145
Integrated Ceiling Components	147
Access Panels	147
VoglModu® QuadRound	150
Stretch Ceilings.....	151
Working Methods	153
Vogl Double Layer Fleece	153
VoglFriestape-Set®	157
Sound Absorption Values	161
Index	177

Picture Gallery

Pictures fascinate – pictures emotionalise – a picture is worth a thousand words.

The picture gallery shows you the manifold possible applications of our products. Our ceiling systems, such as acoustic design ceilings, light and climate control ceilings, ceiling tiles or customised moulded elements, to name just a few examples from our comprehensive portfolio, have been used for many years in numerous public, office and administration buildings, schools, theatres, medical facilities, hotels and restaurants, shopping malls, etc. in Germany and abroad.



Find more pictures under:

www.vogl-deckensysteme.de/en/gallery/index.php



Making a Difference *at the Top*

Ceiling diversity in form, colour and performance



Erich R. Vogl
Managing Director
Vogl Deckensysteme GmbH

Dear reader,

I am happy to see you are interested in our company – you will find it worthwhile!

As an owner-run business, Vogl Deckensysteme GmbH is committed to precision and innovation. I have been running the company since 1985 in second generation and I am sure that it is owed, above all, to our origin in tool and machine construction that we were able to gain lots of helpful skills regarding precision production techniques and a consistently high level of product quality. This wealth of experience gives us an inimitable competitive edge. The perfectly crafted design ceiling is our benchmark. Its focus is on quality, fitting accuracy and reliability of application.

Plasterboard ceiling systems, our basic product, are equipped with a variety of functions so as to fulfil all requirements of modern ceiling design – particularly in highly frequented areas. Acoustic, design, climate control and illuminated ceilings are among our core competencies. Customised moulded components are our specialty.

But in spite of all technical orientation, the customer is always at the centre of our activities! Our approach is result- and practice-oriented, and we offer our customers a large portfolio of services. This is not only to save you time by doing many steps of the work for you, but also to achieve together the best possible result in terms of aesthetics and functionality.

We wish you many more successful projects and hope to have a chance to realise them together with you in the future.

Sincerely yours



Erich R. Vogl
Owner and Managing Director



The modern production plant is situated in the Middle-Franconian town of Emskirchen.



The Vogl Competence Centre is well attended – product training for building material traders, contractors and architects take place there on a regular basis.



Form

Our ceiling elements come in many shapes, so there are virtually no limits to the freedom of design.

Form



"It is our goal to turn buildings into eye-catchers with our ceiling solutions through **form, colour and performance**, and to enhance their **value durably**."

Colour

Creative, coloured ceiling design with factory-tinted ceiling elements in a variety of combinations of finishing coat, inner perforation and fleece.

Colour



Performance

Vogl ceiling systems permit manifold additional functions by integrating illumination and technical installations.

Performance



Contractors/installers

Working overhead is exhausting enough. Therefore, we provide optimum working conditions with well thought-out, practice-oriented products and systems. Our application engineers offer active support in the installation phase of your projects. With additional information and intensive training, we help you achieve more reliable results. We round off our commitment by opening opportunities for new business through intensive project acquisition.

- Practice-oriented products from our in-house manufacture
- Technical support in proper planning and preparation
- Mounting instructions on the job site
- Opening opportunities for new business



Project owners

Vogl ceiling systems provide project owners with aesthetic solutions regarding the interplay of design, light and colours. Besides improved room acoustics, a pleasant room climate can also be achieved by installing climate control ceilings, or air purification through adsorption. This contributes to durably increasing usefulness and real estate value.

- Customised ceiling solutions
- Integration of light and climate
- Top quality
- Assistance to those involved in the project
- Assurance of sustainability

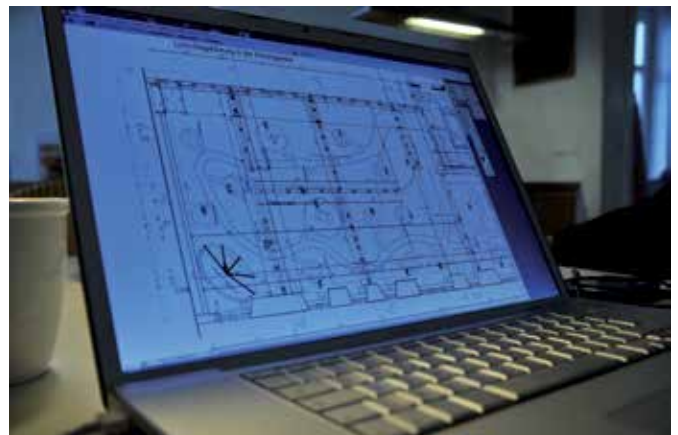

Building material trader

We create market demand for sophisticated ceiling solutions and consequently a significant added value for all compared to the common standard. Through consistent market development and joint campaigns, we introduce installers to the trade who work the market in the high-end contract business with our support.

- Comprehensive product portfolio
- Products from in-house manufacture
- Manufacturer with a sense of service
- Short-term availability
- Training for building material dealers' staff and customers
- Joint market development



Architects/designers

To facilitate your work, we offer any conceivable kind of help, starting with the initial consultation by our project consultant on the wide range of services regarding support in the design, tendering and execution process, all the way to the complete ceiling design.

- Working out and implementing design solutions
- Competent replies to inquiries
- Planning support
- Clarification of details, in particular at interfaces with adjacent disciplines
- Tested system solutions
- Specialist installer companies



Acoustics

Whether seamless acoustic design ceilings with integrated air purification effect or our acoustic plaster system VoglToptec® – our ceiling systems, which are tested for harmful substances, serve as sound absorbers in highly frequented zones and thus create an agreeable room atmosphere.

Acoustics



Design

Modern ceiling design focuses on the interplay between form and colour. Whether floating ceiling, 3D-element or customised moulded components – Vogl Deckensysteme can also implement your idea, and with a high degree of pre-fabrication into the bargain. The components are disassembled to suit site requirements and then simply re-assembled at the job site like a big puzzle.

Design

Light

The dream of many architects and designers comes true: Light sources and ceilings form an optically inseparable unit. Vogl ceiling systems offer, in addition to stretch ceilings, also individually prefabricated moulded gypsum elements, coved lighting and light channels and the perfectly matching light elements.

Light



Climate

Leading in terms of energy efficiency and functionality – conserving energy resources and reducing operating costs should be the objective of sustainable construction. Both aspects can be implemented with the VoglThermotop® heating and cooling ceiling system. Compared to conventional air handling systems, operating costs can be reduced by up to 40 per cent.

Climate

Comprehensive support in every phase of the project





Framework

- Profiles, straight/curved CD/UD
- Suspended brackets/connectors for UA/CD, secondary profile, clamping profile
- Screws

Acoustic ceilings

- VoglFuge
- Compound seam
- GSG4 joint
- Visible chamfer
- Adhesive seam
- Thermotec panels
- Colour panels
- Acoustic plaster ceilings
- Acoustic floating ceilings

Ceiling tiles

- Exposed grid
- Rebated grid
- Concealed grid

Finish

- Acoustic plaster white and tinted
- Ceiling colours white and tinted
- Working methods
- Tools

Moulded components

- Moulded components
- 3D elements

Cooling and heating ceilings

- System with copper meanders
- System with capillary tubes

Illuminated and stretch ceilings

- Illuminated ceilings with stretched material
- Illuminated ceilings with acrylics
- Illuminated ceilings with glass inlays

Integrated components

- Access panels
- Light modules





- Framework
- Acoustic design ceilings
- Ceiling tiles
- Acoustic plaster ceilings
- Acoustic floating ceilings
- Moulded components, 3D design
- Integrated ceiling components
- Stretch ceilings
- Working methods
- Services

Do you have any questions regarding our products, logistics or an offer, or perhaps wish to make a simple enquiry? We are always glad to assist you! Contact us!

Costing & Quotes

- Phone +49(0)9104-825-191 or
Phone +49(0)9104-825-310
- Fax +49(0)9104-825-250

Logistics & Order Processing

- Phone +49(0)9104-825-130 or
Phone +49(0)9104-825-121
- Fax +49(0)9104-825-250

Product Management

- Phone +49(0)9104-825-270
- Fax +49(0)9104-825-240

Marketing & Service

- Phone +49(0)9104-825-105
- Fax +49(0)9104-825-280

or e-mail to:









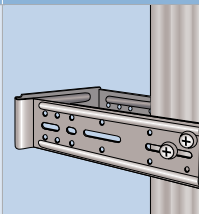

kundencenter@vogl-deckensysteme.de

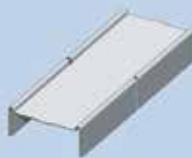

Illustration	Item number	Description	PU PU/large bundle
	10011000	CD profile 60/27/0.6 rK, 1190 mm	12 pcs. (14.28 m) 180 pcs. (214.20 m)
	10026000	CD profile 60/27/0.6 rK, 2600 mm	12 pcs. (31.20 m) 180 pcs. (468.00 m)
	10031000	CD profile 60/27/0.6 rK, 3100 mm	12 pcs. (37.20 m) 180 pcs. (558.00 m)
	10036000	CD profile 60/27/0.6 rK, 3600 mm	12 pcs. (43.20 m) 180 pcs. (648.00 m)
	10040000	CD profile 60/27/0.6 rK, 4000 mm	12 pcs. (48.00 m) 180 pcs. (720.00 m)
	10046000	CD profile 60/27/0.6 rK, 4600 mm	12 pcs. (55.20 m) 180 pcs. (828.00 m)
	10099000	CD profile 60/27/0.6 rK, custom lengths on request	
			Manufactured according to EN 14195
	10230000	UD profile 28/27/0.6, 3000 mm Wall connection profile for CD profiles	16 pcs. (48.00 m) 288 pcs. (864.00 m)
	10068100	CD profile 60/27/0.6 rK, concave, 4000 mm Bend radius min. 500 mm - 1000 mm	
	10068200	CD profile 60/27/0.6 rK, concave, 4000 mm Bend radius > 1001 mm - 2000 mm	
	10068300	CD profile 60/27/0.6 rK, concave, 4000 mm Bend radius > 2001 mm - 4000 mm	
	10068400	CD profile 60/27/0.6 rK, concave, 4000 mm Bend radius > 4000 mm	
	10068500	CD profile 60/27/0.6 rK, concave, special lengths	
		<p>The minimum order quantity per curved radius is 20 linear metres.</p> <p>For production reasons, curved CD profiles come with 150 mm straight sections on each end.</p> <p>Product realisation details: radius (r) + chord (s) or radius (r) + rise (h) or chord (s) + rise (h) or radius (r) + fixed length (b)</p>	 <p style="text-align: right;">concave</p>
	10069100	CD profile 60/27/0.6 rK, convex, 4000 mm Bend radius min. 500 mm - 1000 mm	
	10069200	CD profile 60/27/0.6 rK, convex, 4000 mm Bend radius > 1001 mm - 2000 mm	
	10069300	CD profile 60/27/0.6 rK, convex, 4000 mm Bend radius > 2001 mm - 4000 mm	
	10069400	CD profile 60/27/0.6 rK, convex, 4000 mm Bend radius > 4000 mm	
	10069500	CD profile 60/27/0.6 rK, convex, special lengths Bend radius > 4000 mm	
		<p>The minimum order quantity per curved radius is 20 linear metres.</p> <p>For production reasons, curved CD profiles come with 150 mm straight sections on each end.</p> <p>Product realisation details: radius (r) + chord (s) or radius (r) + rise (h) or chord (s) + rise (h) or radius (r) + fixed length (b)</p>	 <p style="text-align: right;">convex</p>

Illustration	Item number	Description	Application	PU PU/pallet
	20107000	Anchor fast suspension with compression spring, CD 60/27 Initial testing according to EN 13964, 0.25 kN		100 pcs./PU 84 PU/pallet
	20115000	Anchor fast suspension, CD 60/27 Initial testing according to EN 13964, 0.25 kN		100 pcs./PU 84 PU/pallet
	20116000	Anchor suspension, 80 mm, CD 60/27 Initial testing according to EN 13964, 0.25 kN		100 pcs./PU 96 PU/pallet
	20108000	Anchor suspension, 170 mm, CD 60/27 Initial testing according to EN 13964, 0.25 kN		100 pcs./PU 144 PU/pallet
	20127000	Fastening clip, CD 60/27 Initial testing according to EN 13964, 0.15 kN Tolerance compensation up to 20 mm possible		100 pcs./PU 32 PU/pallet
	20534000	Direct mounting clip, CD 60/27 Straps without screws Initial testing according to EN 13964, 0.25 kN Straps with screws with 2 screws LN 3.5 x 9.5 mm Initial testing according to EN 13964, 0.40 kN		100 pcs./PU 32 PU/pallet
	20161000	Direct suspended bracket, 50 mm, 4-hole, CD 60/27		100 pcs./PU 72 PU/pallet
	20162000	Direct suspended bracket, 120 mm, 4-hole, CD 60/27		100 pcs./PU 96 PU/pallet
	20163000	Direct suspended bracket, 200 mm, 4-hole, CD 60/27 Initial testing according to EN 13964, 0.40 kN Delivery includes unbent product		100 pcs./PU 72 PU/pallet
	20261000	Direct suspended bracket, 50 mm, 4-hole, wood 50/30		100 pcs./PU 72 PU/pallet
	20262000	Direct suspended bracket, 120 mm, 4-hole, wood 50/30		100 pcs./PU 96 PU/pallet
	20263000	Direct suspended bracket, 200 mm, 4-hole, wood 50/30 Initial testing according to EN 13964, 0.40 kN Delivery includes unbent product		100 pcs./PU 72 PU/pallet

Illustration	Item number	Description	Application	PU PU/pallet
	20167000	Direct suspended bracket, adjustment 40-70 mm, CD 60/27 Including locking pins Initial testing according to EN 13964, 0.47 kN		50 pcs./PU 66 PU/pallet
	20168000	Direct suspended bracket, adjustment 59-108 mm, CD 60/27 Including locking pins Initial testing according to EN 13964, 0.58 kN		50 pcs./PU 48 PU/pallet
	20135000	Cross connector, CD 60/27 Initial testing according to EN 13964, 0.40 kN Delivery includes unbent product		100 pcs./PU 148 PU/pallet
	20139000	UA cross connector, UA 50/CD 60/27 Initial testing according to EN 13964, 0.40 kN Delivery includes unbent product		100 pcs./PU 148 PU/pallet
	20133000	Anchor bracket, CD 60/27 Initial testing according to EN 13964, 0.25 kN		100 pcs./PU 96 PU/pallet
	20136000	Twisting anchor bracket, CD 60/27 Initial testing according to EN 13964, 0.25 kN  On-site angle adjustment from 30 °- 150 °		100 pcs./PU 96 PU/pallet
	20131000	Support clip, CD 60/27 Clamping width up to 17 mm		50 pcs./PU 136 PU/pallet
	20137300	Adjustable vibration bracket, 30 mm, CD 60/27		100 pcs./PU
	20137400	Adjustable vibration bracket, 45 mm, CD 60/27		102 PU/pallet
	20137600	Adjustable vibration bracket, 60 mm, CD 60/27		100 pcs./PU
	20137900	Adjustable vibration bracket, 90 mm, CD 60/27 Range of applications: wall structures		66 PU/pallet 100 pcs./PU 48 PU/pallet

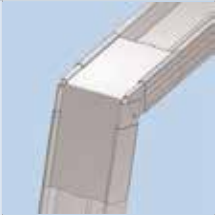
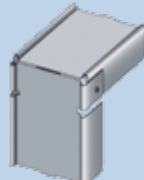
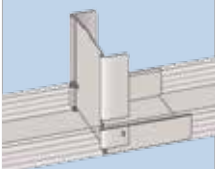
Illustration	Item number	Description	Application	PU PU/pallet
	20137000	Adjustable vibration bracket, G-90 mm, CD 60/27 Delivery includes unbent product Range of applications: wall structures		100 pcs./PU 68 PU/pallet
	20153000	Universal connector, unbent, CD 60/27 Delivery includes unbent product		100 pcs./PU 84 PU/pallet
	20141000	Connector, 80 mm, CD 60/27		100 pcs./PU 32 PU/pallet
	20159000	Connector, lengthwise, CD 60/27		100 pcs./PU 48 PU/pallet
	20140000	Angled connector, flat, CD 60/27 For on-site angle adjustment		100 pcs./PU 24 PU/pallet
	20140100	Angled connector 90°, CD 60/27 Angle default setting is 90°		100 pcs./PU 24 PU/pallet
	20140600	Angled connector 45° - 179°, CD 60/27 Angle default setting according to customer specifications		100 pcs./PU 24 PU/pallet
	20142000	Vertical connector, T-connector, CD 60/27 T-connector movable within the CD profile, suitable, for example, for the installation of luminaire boxes		100 pcs./PU 24 PU/pallet

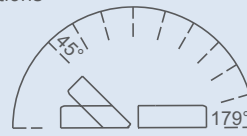
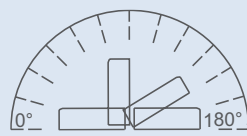











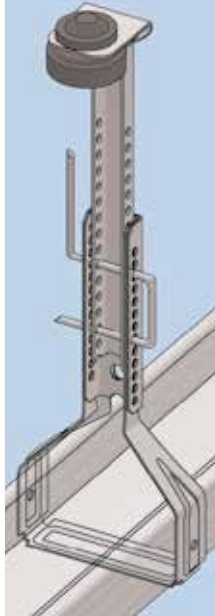

Illustration	Item number	Description	Application	PU PU/pallet
	25501000	Vernier safety bolt Initial testing according to EN 13964, 0.40 kN		100 pcs./PU 288 PU/pallet
	21012000 21025000 21037000 21050000 21075000 21100000 21125000 21150000 21175000 21200000 21250000 21300000 21400000	Eyelet wire , 125 mm Eyelet wire , 250 mm Eyelet wire , 375 mm Eyelet wire , 500 mm Eyelet wire , 750 mm Eyelet wire , 1000 mm Eyelet wire , 1250 mm Eyelet wire , 1500 mm Eyelet wire , 1750 mm Eyelet wire , 2000 mm Eyelet wire , 2500 mm Eyelet wire , 3000 mm Eyelet wire , special lengths upon request Eyelet wire according to EN 13964		100 pcs./PU 300 PU/pallet 200 PU/pallet 150 PU/pallet 100 PU/pallet 100 PU/pallet 100 PU/pallet 100 PU/pallet 100 PU/pallet 50 PU/pallet 50 PU/pallet 50 PU/pallet 50 PU/pallet
	25020000 25030000 25040000 25050000 25060000 25070000 25080000 25090000 25100000 25110000 25120000 25130000 25140000 25150000 25160000 25170000 25180000 25190000 25200000 25400000	Vernier top part , 200 mm, X = 130 Vernier top part , 300 mm, X = 230 Vernier top part , 400 mm, X = 330 Vernier top part , 500 mm, X = 430 Vernier top part , 600 mm, X = 530 Vernier top part , 700 mm, X = 630 Vernier top part , 800 mm, X = 730 Vernier top part , 900 mm, X = 830 Vernier top part , 1000 mm, X = 930 Vernier top part , 1100 mm, X = 1030 Vernier top part , 1200 mm, X = 1130 Vernier top part , 1300 mm, X = 1230 Vernier top part , 1400 mm, X = 1330 Vernier top part , 1500 mm, X = 1430 Vernier top part , 1600 mm, X = 1530 Vernier top part , 1700 mm, X = 1630 Vernier top part , 1800 mm, X = 1730 Vernier top part , 1900 mm, X = 1830 Vernier top part , 2000 mm, X = 1930 Vernier top part , custom lengths on request Initial testing according to EN 13964, 0.40 kN Continuous perforation		100 pcs./PU 60 PU/pallet 60 PU/pallet 60 PU/pallet 56 PU/pallet 56 PU/pallet 48 PU/pallet 48 PU/pallet 28 PU/pallet 28 PU/pallet 25 pcs./PU 25 pcs./PU 25 pcs./PU 25 pcs./PU 25 pcs./PU 25 pcs./PU 25 pcs./PU 25 pcs./PU 25 pcs./PU 25 pcs./PU 25 pcs./PU Pallet units on request from 25 pcs./PU
	25005000	Vernier connector , 90 mm Initial testing according to EN 13964, 0.40 kN		100 pcs./PU 96 PU/pallet

Product Range

Illustration	Item number	Description	Application	PU PU/pallet
	25006000	Vernier rod, 3000 mm Initial testing according to EN 13964, 0.40 kN		25 pcs./PU
	25004000	Vernier coupling Extension max. 170 mm		100 pcs./PU
	20128000	Vernier hanger, CD 60/27 Initial testing according to EN 13964, 0.40 kN		100 pcs./PU 32 PU/pallet
	20128100	Vernier hanger, CD 60/27, incl. security pin Initial testing according to EN 13964, 0.40 kN		100 pcs./PU 32 PU/pallet
	20129000	Vernier hanger, UA 50 Initial testing according to EN 13964, 0.40 kN		100 pcs./PU 32 PU/pallet
	20129100	Vernier hanger, UA 50, incl. security pin Initial testing according to EN 13964, 0.40 kN		100 pcs./PU 32 PU/pallet
	20151000	Vernier bottom part, CD 60/27 Initial testing according to EN 13964, 0.25 kN		100 pcs./PU 108 PU/pallet
	20537000	Vernier bottom part, transverse suspension, rotating, CD 60/27 Initial testing according to EN 13964, 0.25 kN Excellently suited for multiple diagonal suspension, e.g. in staircases, fully rotating (due to diagonal suspension, always use tapping screws LN 9.5 for fixing)		100 pcs./PU 32 PU/pallet
	20536000	Direct mounting vibration clip, 4 mm, CD 60/27 Straps without screws Initial testing according to EN 13964, 0.25 kN Straps with screws with 2 screws LN 3.5 x 9.5 mm Initial testing according to EN 13964, 0.40 kN		100 pcs./PU 32 PU/pallet
	20164000	Direct vibration hanger, 50 mm, 4-hole, CD 60/27		100 pcs./PU 24 PU/pallet
	20165000	Direct vibration hanger, 120 mm, 4-hole, CD 60/27		100 pcs./PU 32 PU/pallet
	20166000	Direct vibration hanger, 200 mm, 4-hole, CD 60/27 Initial testing according to EN 13964, 0.40 kN Delivery includes unbent product		100 pcs./PU 15 PU/pallet

Illustration	Item number	Description	Application	PU PU/pallet
	21012100 21025100 21037100 21050100 21075100 21100100 21400100	Eyelet wire, 125 mm Eyelet wire, 250 mm Eyelet wire, 375 mm Eyelet wire, 500 mm Eyelet wire, 750 mm Eyelet wire, 1000 mm Eyelet wire, special lengths on request Eyelet wire according to EN 13964 With vibration element 4 mm		100 pcs./PU 180 PU/pallet 96 PU/pallet 42 PU/pallet 28 PU/pallet 24 PU/pallet 24 PU/pallet
	25020100 25030100 25040100 25050100 25060100 25070100 25080100 25090100 25100100 25400100	Vernier top part, 200 mm, X = 130 Vernier top part, 300 mm, X = 230 Vernier top part, 400 mm, X = 330 Vernier top part, 500 mm, X = 430 Vernier top part, 600 mm, X = 530 Vernier top part, 700 mm, X = 630 Vernier top part, 800 mm, X = 730 Vernier top part, 900 mm, X = 830 Vernier top part, 1000 mm, X = 930 Vernier top part, custom lengths on request Initial testing according to EN 13964, 0.40 kN Continuous perforation With vibration element 4 mm		100 pcs./PU 36 PU/pallet 36 PU/pallet 36 PU/pallet 24 PU/pallet 24 PU/pallet 24 PU/pallet 18 PU/pallet 18 PU/pallet 18 PU/pallet

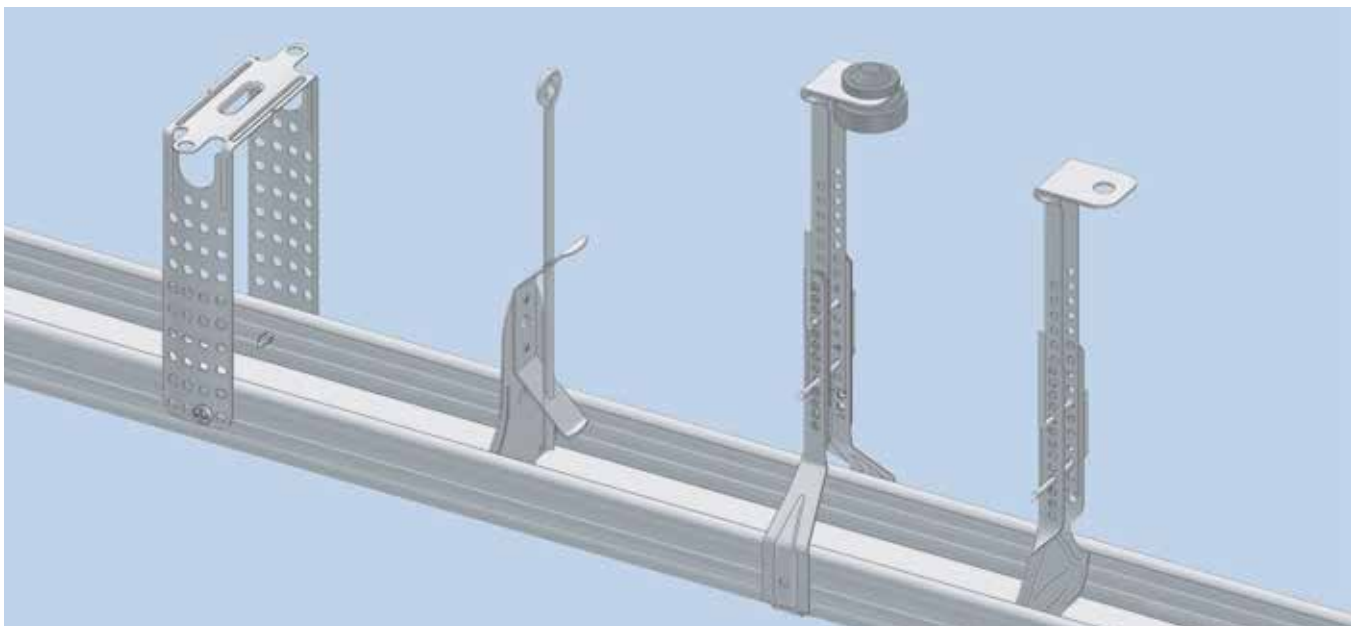















Illustration	Item number	Description	Application	PU PU/pallet
	22012000 22025000 22037000 22050000 22075000 22100000 22125000 22150000 22175000 22200000 22250000 22300000 22400000	Hooked wire, 125 mm Hooked wire, 250 mm Hooked wire, 375 mm Hooked wire, 500 mm Hooked wire, 750 mm Hooked wire, 1000 mm Hooked wire, 1250 mm Hooked wire, 1500 mm Hooked wire, 1750 mm Hooked wire, 2000 mm Hooked wire, 2500 mm Hooked wire, 3000 mm Hooked wire, special lengths on request Hooked wire according to EN 13964		100 pcs./PU 300 PU/pallet 200 PU/pallet 150 PU/pallet 100 PU/pallet 100 PU/pallet 100 PU/pallet 100 PU/pallet 100 PU/pallet 50 PU/pallet 50 PU/pallet 50 PU/pallet 50 PU/pallet
	23100000	Double spring clip, equilateral		100 pcs./PU 105 PU/pallet
	23110100 23110200 23110300 23110400	Easy-span hanger, hooked wire/hooked wire Easy-span hanger, HH, ~ 200 - 300 mm Easy-span hanger, HH, ~ 300 - 600 mm Easy-span hanger, HH, ~ 500 - 1000 mm Easy-span hanger, HH, ~1000-2000 mm		100 pcs./PU 50 PU/pallet 30 PU/pallet 20 PU/pallet 10 PU/pallet
	23120100 23120200 23120300 23120400	Easy-span hanger, hooked wire/eyelet wire Easy-span hanger, HE, ~ 200 - 300 mm Easy-span hanger, HE, ~ 300 - 600 mm Easy-span hanger, HE, ~ 500 - 1000 mm Easy-span hanger, HE, ~1000 - 2000 mm		100 pcs./PU 50 PU/pallet 30 PU/pallet 20 PU/pallet 10 PU/pallet
	22412500 22425000	Hooked wire with double spring clip, 125 mm, bottom part U-1 Hooked wire with double spring clip, 250 mm, bottom part U-2		100 pcs./PU 96 PU/pallet 100 pcs./PU 50 PU/pallet
	20311000	Quick hanger for T-profile Initial testing according to EN 13964, 0.25 kN		100 pcs./PU 84 PU/pallet
	20312000	Quick hanger for T-profile, Klick Fix II with mounted safety plate Initial testing according to EN 13964, 0.32 kN		100 pcs./PU 170 PU/pallet



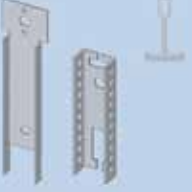



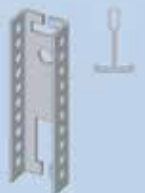

Illustration	Item number	Description	Application	PU PU/pallet
	25003000	Vernier suspended bracket, bottom part for T-profile Initial testing according to EN 13964, 0.42 kN		100 pcs./PU 220 PU/pallet
	25001000	Vernier short hanger, set 40 - 80 mm for T-profile and double-T-profile		100 pcs./PU 220 PU/pallet
	25001300	Vernier short hanger, set 60 - 100 mm for T-profile and double-T-profile		100 pcs./PU 220 PU/pallet
	25001500	Vernier short hanger, set 80 - 120 mm for T-profile and double-T-profile		100 pcs./PU 220 PU/pallet
	25002000	Vernier short hanger, top part 47 mm		100 pcs./PU
	25002300	Vernier short hanger, top part 72 mm		100 pcs./PU
	25002500	Vernier short hanger, top part 100 mm		100 pcs./PU
	25005100	Vernier short hanger, bottom part for T-profile and double-T-profile		100 pcs./PU



Illustration	Item number	Description	Application	PU PU/pallet
	20333000	Connector, CD 60/27, clamping profile Initial testing according to EN 13964, 0.57 kN		100 pcs./PU 96 PU/pallet
	20316000	Quick hanger for clamping profile Initial testing according to EN 13964, 0.51 kN		100 pcs./PU 170 PU/pallet
	25003500	Vernier suspended bracket, bottom part for clamping profile		100 pcs./PU 220 PU/pallet
	25005500	Vernier short hanger, bottom part, clamping profile Initial testing according to EN 13964, 0.38 kN		100 pcs./PU 220 PU/pallet
	20334000	Connector, longitudinal, clamping profile		100 pcs./PU 96 PU/pallet

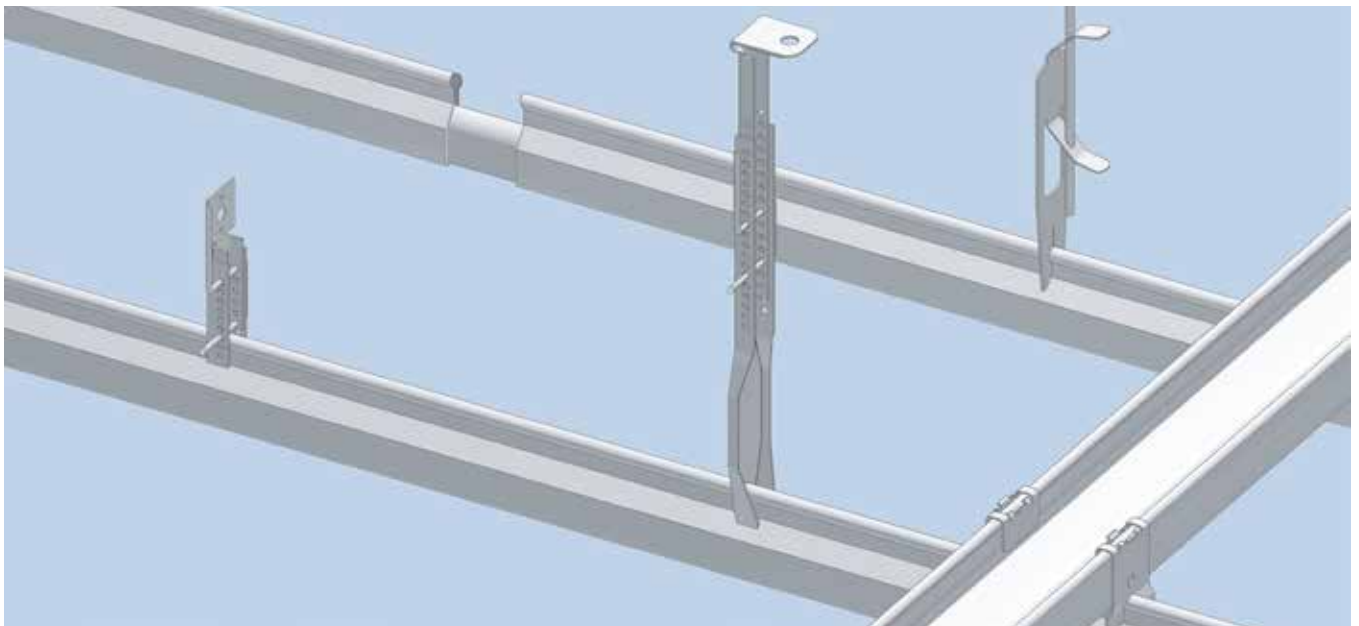
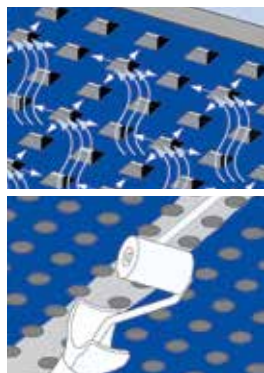

Illustration	Item number	Description	Dimensions	PU PU/pallet
	50435000	Wafer head screw FN 35 with needle point To connect hangers to wooden elements	5.1 x 35 mm	100 pcs./PU
	50525000	Drywall screw SBS TN 25 with countersunk head and needle point	3.5 x 25 mm	1000 pcs./PU 540 PU/pallet
	50535000	Drywall screw SBS TN 35 with countersunk head and needle point To mount plasterboards to metal framework (up to max. 0.7 mm without pre-drilling)	3.5 x 35 mm	1000 pcs./PU 438 PU/pallet
	50735000	Drywall screw SBS TB 35 with countersunk head and drill bit To mount plasterboards to metal framework from 0.7 mm to 2.25 mm sheet metal thickness	3.5 x 35 mm	1000 pcs./PU 438 PU/pallet
	50809000	LN 9.5 tapping screw with needle point To fasten suspended brackets and sheet steel profiles up to max. 0.7 mm sheet thickness	3.5 x 9.5 mm	1000 pcs./PU 612 PU/pallet
	52130000	Perforated panel screw SN 30 with needle point Phosphated special screw with pressed-on small countersunk head (cross slot PH2).	3.5 x 30 mm	1000 pcs./PU 468 PU/pallet
	52160000	Perforated panel screw SN 40 Phosphated special screw with pressed-on small countersunk head (cross slot PH2)	3.5 x 40 mm	1000 pcs./PU
	52150000	Perforated panel screw, gold, TB 23 Corrosion-resistant special screw with countersunk head (cross slot PH2) Recommended for VoglThermotec panels and VoglThermotec panels PLUS (containing graphite)	3.5 x 23 mm	1000 pcs./PU



The Voglfuge® System of Vogl acoustic design ceilings is represented by perforated ceiling panels with high acoustic performance and air purification effect (adsorption).

Black or white acoustic fleece backing (other fleece colours on request), all sides sharp-edged with undercut for installation using the quickest and most secure edge to edge laying principle.

Other available options: Vogl acoustic design panels with non-perforated edges, block perforation, applications, manufacture in accordance with customer designs and ceiling plans.

Delivery including Voglfuge® System Kit (incl. perforated panel screws SN 3.5x30).

Standards: EN 14190 "Gypsum plasterboard products from reprocessing"
Material class: A2-s1, d0 (non-flammable) according to EN 13501
Long edge: SK (sharp-edged)
Short edge: SK (sharp-edged)

with air purification effect as standard



Product Range

Illustration	Item number	Description	Details	m ² /pallet Panels/pallet
	7061101110	Acoustic design panel VF 6/18R Acoustic fleece, black	1188 x 1998 x 12.5 mm	59.3 m ²
	7061101120	Acoustic design panel VF 6/18R Acoustic fleece, white	Perforated area: 8.7 % Mass: 9.1 kg/m ²	25 pcs.
	7061102110	Acoustic design panel VF 8/18R Acoustic fleece, black	1188 x 1998 x 12.5 mm	59.3 m ²
	7061102120	Acoustic design panel VF 8/18R Acoustic fleece, white	Perforated area: 15.5 % Mass: 8.5 kg/m ²	25 pcs.
	7061103110	Acoustic design panel VF 10/23R Acoustic fleece, black	1196 x 2001 x 12.5 mm	59.8 m ²
	7061103120	Acoustic design panel VF 10/23R Acoustic fleece, white	Perforated area: 14.8 % Mass: 8.5 kg/m ²	25 pcs.
	7061104110	Acoustic design panel VF 12/25R Acoustic fleece, black	1200 x 2000 x 12.5 mm	60.0 m ²
	7061104120	Acoustic design panel VF 12/25R Acoustic fleece, white	Perforated area: 18.1 % Mass: 8.2 kg/m ²	25 pcs.
	7061105110	Acoustic design panel VF 15/30R Acoustic fleece, black	1200 x 1980 x 12.5 mm	59.4 m ²
	7061105120	Acoustic design panel VF 15/30R Acoustic fleece, white	Perforated area: 19.6 % Mass: 8.0 kg/m ²	25 pcs.
	7061106110	Acoustic design panel VF 8/12/50R Acoustic fleece, black	1200 x 2000 x 12.5 mm	60.0 m ²
	7061106120	Acoustic design panel VF 8/12/50R Acoustic fleece, white	Perforated area: 13.1 % Mass: 8.7 kg/m ²	25 pcs.
	7061107110	Acoustic design panel VF 12/20/66R Acoustic fleece, black	1188 x 1980 x 12.5 mm	58.8 m ²
	7061107120	Acoustic design panel VF 12/20/66R Acoustic fleece, white	Perforated area: 19.6 % Mass: 8.0 kg/m ²	25 pcs.
	7061108110	Acoustic design panel VF 8/18Q Acoustic fleece, black	1188 x 1998 x 12.5 mm	59.3 m ²
	7061108120	Acoustic design panel VF 8/18Q Acoustic fleece, white	Perforated area: 19.8 % Mass: 8.0 kg/m ²	25 pcs.
	7061109110	Acoustic design panel VF 12/25Q Acoustic fleece, black	1200 x 2000 x 12.5 mm	60.0 m ²
	7061109120	Acoustic design panel VF 12/25Q Acoustic fleece, white	Perforated area: 23.0 % Mass: 7.7 kg/m ²	25 pcs.
	7061110110	Acoustic design panel VF 8/15/20R Acoustic fleece, black	1200 x 2000 x 12.5 mm	60.0 m ² *
	7061110120	Acoustic design panel VF 8/15/20R Acoustic fleece, white	Perforated area: 9.5 % Mass: 9.1 kg/m ²	25 pcs.
	7061111110	Acoustic design panel VF 12/20/35R Acoustic fleece, black	1200 x 2000 x 12.5 mm	60.0 m ² *
	7061111120	Acoustic design panel VF 12/20/35R Acoustic fleece, white	Perforated area: 11.0 % Mass: 8.9 kg/m ²	25 pcs.
	7061112110	Acoustic design panel VF 5/82/15.4SL Acoustic fleece, black	1186 x 1984 x 12.5 mm	58.8 m ²
	7061112120	Acoustic design panel VF 5/82/15.4SL Acoustic fleece, white	Perforated area: 21.5 % Mass: 7.9 kg/m ²	25 pcs.

*Note: Despite being perforated irregularly, random perforation panels still yield a certain linear layout as the abutting panel edges must be non-perforated in any case. This is unavoidable and independent of the workmanship of the specialist contractor.

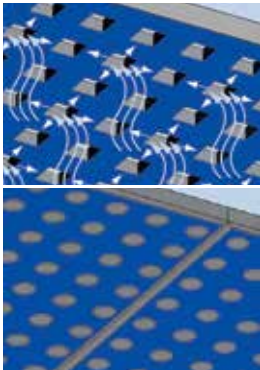

Vogl acoustic design panels compound seam system are perforated ceiling panels with high acoustic performance and air purification effect (adsorption).

Black or white acoustic fleece backing (other fleece colours on request).







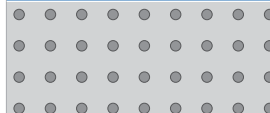
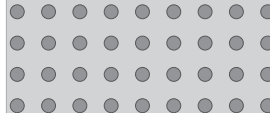
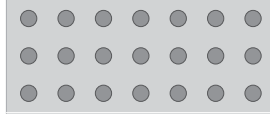

Other available options: Vogl acoustic design panels with non-perforated edges, block perforation, applications, manufacture in accordance with customer designs and ceiling plans.

Other available options: Vogl acoustic design panels with non-perforated edges, block perforation, applications, manufactured in accordance with customer designs and ceiling plans.

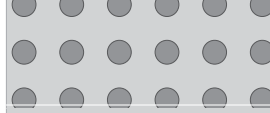
Standards: EN 14190 "Gypsum plasterboard products from reprocessing"
Material class: A2-s1, d0 (non-combustible) according to EN 13501
Long edge: SK (sharp-edged)
Short edge: SK (sharp-edge)

with air purification
 effect as standard

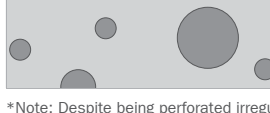

Illustration	Item number	Description	Details	m ² /pallet Panels/pallet
	7071101110	Acoustic design panel SF 6/18R Acoustic fleece, black	1188 x 1998 x 12.5 mm Perforated area: 8.7 % Mass: 9.1 kg/m ²	59.3 m ² 25 pcs.
	7071101120	Acoustic design panel SF 6/18R Acoustic fleece, white		
	7071102110	Acoustic design panel SF 8/18R Acoustic fleece, black	1188 x 1998 x 12.5 mm Perforated area: 15.5 % Mass: 8.5 kg/m ²	59.3 m ² 25 pcs.
	7071102120	Acoustic design panel SF 8/18R Acoustic fleece, white		
	7071103110	Acoustic design panel SF 10/23R Acoustic fleece, black	1196 x 2001 x 12.5 mm Perforated area: 14.8 % Mass: 8.5 kg/m ²	59.8 m ² 25 pcs.
	7071103120	Acoustic design panel SF 10/23R Acoustic fleece, white		
	7071104110	Acoustic design panel SF 12/25R Acoustic fleece, black	1200 x 2000 x 12.5 mm Perforated area: 18.1 % Mass: 8.2 kg/m ²	60.0 m ² 25 pcs.
	7071104120	Acoustic design panel SF 12/25R Acoustic fleece, white		
	7071105110	Acoustic design panel SF 15/30R Acoustic fleece, black	1200 x 1980 x 12.5 mm Perforated area: 19.6 % Mass: 8.0 kg/m ²	59.4 m ² 25 pcs.
	7071105120	Acoustic design panel SF 15/30R Acoustic fleece, white		
	7071106110	Acoustic design panel SF 8/12/50R Acoustic fleece, black	1200 x 2000 x 12.5 mm Perforated area: 13.1 % Mass: 8.7 kg/m ²	60.0 m ² 25 pcs.
	7071106120	Acoustic design panel SF 8/12/50R Acoustic fleece, white		
	7071107110	Acoustic design panel SF 12/20/66R Acoustic fleece, black	1188 x 1980 x 12.5 mm Perforated area: 19.6 % Mass: 8.0 kg/m ²	58.8 m ² 25 pcs.
	7071107120	Acoustic design panel SF 12/20/66R Acoustic fleece, white		
	7071108110	Acoustic design panel SF 8/18Q Acoustic fleece, black	1188 x 1998 x 12.5 mm Perforated area: 19.8 % Mass: 8.0 kg/m ²	59.3 m ² 25 pcs.
	7071108120	Acoustic design panel SF 8/18Q Acoustic fleece, white		
	7071109110	Acoustic design panel SF 12/25Q Acoustic fleece, black	1200 x 2000 x 12.5 mm Perforated area: 23.0 % Mass: 7.7 kg/m ²	60.0 m ² 25 pcs.
	7071109120	Acoustic design panel SF 12/25Q Acoustic fleece, white		
	7071110110	Acoustic design panel SF 8/15/20R Acoustic fleece, black	1200 x 2000 x 12.5 mm Perforated area: 9.5 % Mass: 9.1 kg/m ²	60.0 m ² * 25 pcs.
	7071110120	Acoustic design panel SF 8/15/20R Acoustic fleece, white		
	7071111110	Acoustic design panel SF 12/20/35R Acoustic fleece, black	1200 x 2000 x 12.5 mm Perforated area: 11.0 % Mass: 8.9 kg/m ²	60.0 m ² 25 pcs.
	7071111120	Acoustic design panel SF 12/20/35R Acoustic fleece, white		

*Note: Despite being perforated irregularly, random perforation panels still yield a certain linear layout as the abutting panel edges must be non-perforated in any case. This is unavoidable and independent of the workmanship of the specialist contractor.

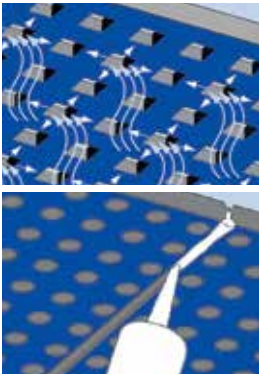

Vogl acoustic design panels GSG4 system are perforated ceiling panels with high acoustic performance and air purification effect (adsorption).

Black or white acoustic fleece backing (other fleece colours on request).

Other available options: Vogl acoustic design panels with non-perforated edges, block perforation, applications, manufacture in accordance with customer designs and ceiling plans.

Standards: EN 14190 "Gypsum plasterboard products from reprocessing"
Material class: A2-s1, d0 (non-flammable) according to EN 13501
Long edge: GSG4 edge
Short edge: GSG4 edge



Illustration	Item number	Description	Details	m ² /pallet Panels/pallet
	7081101110	Acoustic design panel GSG4 6/18R Acoustic fleece, black	1188 x 1998 x 12.5 mm	59.3 m ²
	7081101120	Acoustic design panel GSG4 6/18R Acoustic fleece, white	Perforated area: 8.7 % Mass: 9.1 kg/m ²	25 pcs.
	7081102110	Acoustic design panel GSG4 8/18R Acoustic fleece, black	1188 x 1998 x 12.5 mm	59.3 m ²
	7081102120	Acoustic design panel GSG4 8/18R Acoustic fleece, white	Perforated area: 15.5 % Mass: 8.5 kg/m ²	25 pcs.
	7081103110	Acoustic design panel GSG4 10/23R Acoustic fleece, black	1196 x 2001 x 12.5 mm	59.8 m ²
	7081103120	Acoustic design panel GSG4 10/23R Acoustic fleece, white	Perforated area: 14.8 % Mass: 8.5 kg/m ²	25 pcs.
	7081104110	Acoustic design panel GSG4 12/25R Acoustic fleece, black	1200 x 2000 x 12.5 mm	60.0 m ²
	7081104120	Acoustic design panel GSG4 12/25R Acoustic fleece, white	Perforated area: 18.1 % Mass: 8.2 kg/m ²	25 pcs.
	7081105110	Acoustic design panel GSG4 15/30R Acoustic fleece, black	1200 x 1980 x 12.5 mm	59.4 m ²
	7081105120	Acoustic design panel GSG4 15/30R Acoustic fleece, white	Perforated area: 19.6 % Mass: 8.0 kg/m ²	25 pcs.
	7081106110	Acoustic design panel GSG4 8/12/50R Acoustic fleece, black	1200 x 2000 x 12.5 mm	60.0 m ²
	7081106120	Acoustic design panel GSG4 8/12/50R Acoustic fleece, white	Perforated area: 13.1 % Mass: 8.7 kg/m ²	25 pcs.
	7081107110	Acoustic design panel GSG4 12/20/66R Acoustic fleece, black	1188 x 1980 x 12.5 mm	58.8 m ²
	7081107120	Acoustic design panel GSG4 12/20/66R Acoustic fleece, white	Perforated area: 19.6 % Mass: 8.0 kg/m ²	25 pcs.
	7081108110	Acoustic design panel GSG4 8/18Q Acoustic fleece, black	1188 x 1998 x 12.5 mm	59.3 m ²
	7081108120	Acoustic design panel GSG4 8/18Q Acoustic fleece, white	Perforated area: 19.8 % Mass: 8.0 kg/m ²	25 pcs.
	7081109110	Acoustic design panel GSG4 12/25Q Acoustic fleece, black	1200 x 2000 x 12.5 mm	60.0 m ²
	7081109120	Acoustic design panel GSG4 12/25Q Acoustic fleece, white	Perforated area: 23.0 % Mass: 7.7 kg/m ²	25 pcs.
	7081110110	Acoustic design panel GSG4 8/15/20R Acoustic fleece, black	1200 x 2000 x 12.5 mm	60.0 m ² *
	7081110120	Acoustic design panel GSG4 8/15/20R Acoustic fleece, white	Perforated area: 9.5 % Mass: 9.1 kg/m ²	25 pcs.
	7081111110	Acoustic design panel GSG4 12/20/35R Acoustic fleece, black	1200 x 2000 x 12.5 mm	60.0 m ² *
	7081111120	Acoustic design panel GSG4 12/20/35R Acoustic fleece, white	Perforated area: 11.0 % Mass: 8.9 kg/m ²	25 pcs.

*Note: Despite being perforated irregularly, random perforation panels still yield a certain linear layout as the abutting panel edges must be non-perforated in any case. This is unavoidable and independent of the workmanship of the specialist contractor.

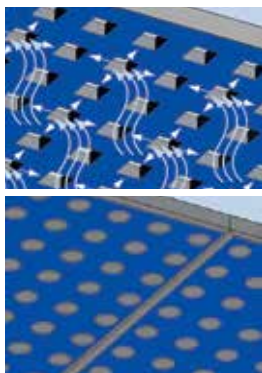

Visible Chamfer acoustic design panels by Vogl are perforated ceiling panels with high acoustic performance and air purification effect (adsorption). Black or white acoustic fleece backing (other fleece colours on request), four-side sharp-edged as a visible chamfer for installation by means of the quickest and most reliable edge to edge installation principle.

Other available options: Vogl acoustic design panels with non-perforated edges, block perforation, applications, manufactured in accordance with customer designs and ceiling plans.

Standards: EN 14190 "Gypsum plasterboard products from reprocessing"
Material class: A2-s1, d0 (non-combustible) according to EN 13501
Long edge: Visible Chamfer 3 x 3 mm
Short edge: Visible Chamfer 3 x 3 mm

with air purification
effect as standard



Illustration	Item number	Description	Details	m ² /pallet Panels/pallet
	7101101110	Acoustic design panel Visible Chamfer 6/18R Acoustic fleece, black	1188 x 1998 x 12.5 mm	59.3 m ²
	7101101120	Acoustic design panel Visible Chamfer 6/18R Acoustic fleece, white	Perforated area: 8.7% Mass: 9.1 kg/m ²	25 pcs.
	7101102110	Acoustic design panel Visible Chamfer 8/18R Acoustic fleece, black	1188 x 1998 x 12.5 mm	59.3 m ²
	7101102120	Acoustic design panel Visible Chamfer 8/18R Acoustic fleece, white	Perforated area: 15.5% Mass: 8.5 kg/m ²	25 pcs.
	7101103110	Acoustic design panel Visible Chamfer 10/23R Acoustic fleece, black	1196 x 2001 x 12.5 mm	59.8 m ²
	7101103120	Acoustic design panel Visible Chamfer 10/23R Acoustic fleece, white	Perforated area: 14.8% Mass: 8.5 kg/m ²	25 pcs.
	7101104110	Acoustic design panel Visible Chamfer 12/25R Acoustic fleece, black	1200 x 2000 x 12.5 mm	60.0 m ²
	7101104120	Acoustic design panel Visible Chamfer 12/25R Acoustic fleece, white	Perforated area: 18.1% Mass: 8.2 kg/m ²	25 pcs.
	7101105110	Acoustic design panel Visible Chamfer 15/30R Acoustic fleece, black	1200 x 1980 x 12.5 mm	59.4 m ²
	7101105120	Acoustic design panel Visible Chamfer 15/30R Acoustic fleece, white	Perforated area: 19.6% Mass: 8.0 kg/m ²	25 pcs.
	7101106110	Acoustic design panel Visible Chamfer 8/12/50R Acoustic fleece, black	1200 x 2000 x 12.5 mm	60.0 m ²
	7101106120	Acoustic design panel Visible Chamfer 8/12/50R Acoustic fleece, white	Perforated area: 13.1% Mass: 8.7 kg/m ²	25 pcs.
	7101107110	Acoustic design panel Visible Chamfer 12/20/66R Acoustic fleece, black	1188 x 1980 x 12.5 mm	58.8 m ²
	7101107120	Acoustic design panel Visible Chamfer 12/20/66R Acoustic fleece, white	Perforated area: 19.6% Mass: 8.0 kg/m ²	25 pcs.
	7101108110	Acoustic design panel Visible Chamfer 8/18Q Acoustic fleece, black	1188 x 1998 x 12.5 mm	59.3 m ²
	7101108120	Acoustic design panel Visible Chamfer 8/18Q Acoustic fleece, white	Perforated area: 19.8% Mass: 8.0 kg/m ²	25 pcs.
	7101109110	Acoustic design panel Visible Chamfer 12/25Q Acoustic fleece, black	1200 x 2000 x 12.5 mm	60.0 m ²
	7101109120	Acoustic design panel Visible Chamfer 12/25Q Acoustic fleece, white	Perforated area: 23.0% Mass: 7.7 kg/m ²	25 pcs.
	7101110110	Acoustic design panel Visible Chamfer 8/15/20R Acoustic fleece, black	1200 x 2000 x 12.5 mm	60.0 m ²
	7101110120	Acoustic design panel Visible Chamfer 8/15/20R Acoustic fleece, white	Perforated area: 9.5% Mass: 9.1 kg/m ²	25 pcs.
	7101111110	Acoustic design panel Visible Chamfer 12/20/35R Acoustic fleece, black	1200 x 2000 x 12.5 mm	60.0 m ²
	7101111120	Acoustic design panel Visible Chamfer 12/20/35R Acoustic fleece, white	Perforated area: 11.0% Mass: 8.9 kg/m ²	25 pcs.

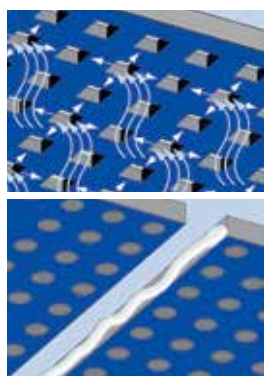

Adhesive Seam system Vogl acoustic design panels are perforated ceiling panels with high acoustic performance and air purification effect (adsorption).

Black or white acoustic fleece backing (other fleece colours on request).

Other available options: Vogl acoustic design panels with non-perforated edges, block perforation, applications, manufacture in accordance with customer designs and ceiling plans.

Standards: EN 14190 "Gypsum plasterboard products from reprocessing"
Material class: A2-s1, d0 (non-flammable) according to EN 13501
Long edge: SK (sharp-edged)
Short edge: SK (sharp-edged)

with air purification
 effect as standard



Illustration	Item number	Description	Details	m ² /pallet Panels/pallet
	7091101110	Acoustic design panel KF 6/18R Acoustic fleece, black	1188 x 1998 x 12.5 mm	59.3 m ²
	7091101120	Acoustic design panel KF 6/18R Acoustic fleece, white	Perforated area: 8.7 % Mass: 9.1 kg/m ²	25 pcs.
	7091102110	Acoustic design panel KF 8/18R Acoustic fleece, black	1188 x 1998 x 12.5 mm	59.3 m ²
	7091102120	Acoustic design panel KF 8/18R Acoustic fleece, white	Perforated area: 15.5 % Mass: 8.5 kg/m ²	25 pcs.
	7091103110	Acoustic design panel KF 10/23R Acoustic fleece, black	1196 x 2001 x 12.5 mm	59.8 m ²
	7091103120	Acoustic design panel KF 10/23R Acoustic fleece, white	Perforated area: 14.8 % Mass: 8.5 kg/m ²	25 pcs.
	7091104110	Acoustic design panel KF 12/25R Acoustic fleece, black	1200 x 2000 x 12.5 mm	60.0 m ²
	7091104120	Acoustic design panel KF 12/25R Acoustic fleece, white	Perforated area: 18.1 % Mass: 8.2 kg/m ²	25 pcs.
	7091105110	Acoustic design panel KF 15/30R Acoustic fleece, black	1200 x 1980 x 12.5 mm	59.4 m ²
	7091105120	Acoustic design panel KF 15/30R Acoustic fleece, white	Perforated area: 19.6 % Mass: 8.0 kg/m ²	25 pcs.
	7091106110	Acoustic design panel KF 8/12/50R Acoustic fleece, black	1200 x 2000 x 12.5 mm	60.0 m ²
	7091106120	Acoustic design panel KF 8/12/50R Acoustic fleece, white	Perforated area: 13.1 % Mass: 8.7 kg/m ²	25 pcs.
	7091107110	Acoustic design panel KF 12/20/66R Acoustic fleece, black	1188 x 1980 x 12.5 mm	58.8 m ²
	7091107120	Acoustic design panel KF 12/20/66R Acoustic fleece, white	Perforated area: 19.6 % Mass: 8.0 kg/m ²	25 pcs.
	7091108110	Acoustic design panel KF 8/18Q Acoustic fleece, black	1188 x 1998 x 12.5 mm	59.3 m ²
	7091108120	Acoustic design panel KF 8/18Q Acoustic fleece, white	Perforated area: 19.8 % Mass: 8.0 kg/m ²	25 pcs.
	7091109110	Acoustic design panel KF 12/25Q Acoustic fleece, black	1200 x 2000 x 12.5 mm	60.0 m ²
	7091109120	Acoustic design panel KF 12/25Q Acoustic fleece, white	Perforated area: 23.0 % Mass: 7.7 kg/m ²	25 pcs.
	7091110110	Acoustic design panel 8/15/20R Acoustic fleece, black	1200 x 2000 x 12.5 mm	60.0 m ² *
	7091110120	Acoustic design panel 8/15/20R Acoustic fleece, white	Perforated area: 9.5 % Mass: 9.1 kg/m ²	25 pcs.
	7091111110	Acoustic design panel KF 12/20/35R Acoustic fleece, black	1200 x 2000 x 12.5 mm	60.0 m ² *
	7091111120	Acoustic design panel KF 12/20/35R Acoustic fleece, white	Perforated area: 11.0 % Mass: 8.9 kg/m ²	25 pcs.

*Note: Despite being perforated irregularly, random perforation panels still yield a certain linear layout as the abutting panel edges must be non-perforated in any case. This is unavoidable and independent of the workmanship of the specialist contractor.

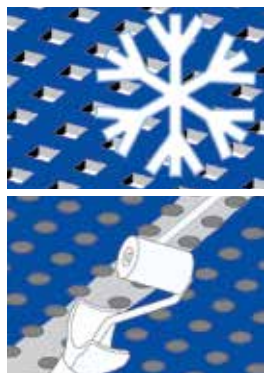

Voglfuge® system VoglThermotecplatten® are perforated ceiling panels with high acoustic performance, defined heat conductivity $\lambda \geq 0.25$ and air purification effect.

Black or white acoustic fleece backing (other fleece colours on request), all sides sharp-edged with undercut for installation using the quickest and most secure edge to edge laying principle.

Other available options: VoglThermotec panels with non-perforated edges, block perforation, applications, manufacture in accordance with customer designs and ceiling plans.

Delivery including Voglfuge® system kit. (without screws).

For the screwing, we recommend art.no. 52150000 "perforated panel screw, gold, TB 23".

Standards: EN 14190 "Gypsum plasterboard products from reprocessing"
Material class: A2-s1, d0 (non-flammable) according to EN 13501
Long edge: SK (sharp-edged)
Short edge: SK (sharp-edged)



Illustration	Item number	Description	Details	m ² /pallet Panels/pallet
	7151101110	Thermotec panel VF 6/18R Acoustic fleece, black	1188 x 1998 x 10.0 mm	75.84 m ²
	7151101120	Thermotec panel VF 6/18R Acoustic fleece, white	Perforated area: 8.7 % Mass: 9.1 kg/m ²	32 pcs.
	7151102110	Thermotec panel VF 8/18R Acoustic fleece, black	1188 x 1998 x 10.0 mm	75.84 m ²
	7151102120	Thermotec panel VF 8/18R Acoustic fleece, white	Perforated area: 15.5 % Mass: 8.5 kg/m ²	32 pcs.
	7151103110	Thermotec panel VF 10/23R Acoustic fleece, black	1196 x 2001 x 10.0 mm	76.48 m ²
	7151103120	Thermotec panel VF 10/23R Acoustic fleece, white	Perforated area: 14.8 % Mass: 8.5 kg/m ²	32 pcs.
	7151104110	Thermotec panel VF 12/25R Acoustic fleece, black	1200 x 2000 x 10.0 mm	76.80 m ²
	7151104120	Thermotec panel VF 12/25R Acoustic fleece, white	Perforated area: 18.1 % Mass: 8.2 kg/m ²	32 pcs.
	7151105110	Thermotec panel VF 15/30R Acoustic fleece, black	1200 x 1980 x 10.0 mm	76.16 m ²
	7151105120	Thermotec panel VF 15/30R Acoustic fleece, white	Perforated area: 19.6 % Mass: 8.0 kg/m ²	32 pcs.
	7151106110	Thermotec panel VF 8/12/50R Acoustic fleece, black	1200 x 2000 x 10.0 mm	76.80 m ²
	7151106120	Thermotec panel VF 8/12/50R Acoustic fleece, white	Perforated area: 13.1 % Mass: 8.7 kg/m ²	32 pcs.
	7151107110	Thermotec panel VF 12/20/66R Acoustic fleece, black	1188 x 1980 x 10.0 mm	75.20 m ²
	7151107120	Thermotec panel VF 12/20/66R Acoustic fleece, white	Perforated area: 19.6 % Mass: 8.0 kg/m ²	32 pcs.
	7151108110	Thermotec panel VF 8/18Q Acoustic fleece, black	1188 x 1998 x 10.0 mm	75.84 m ²
	7151108120	Thermotec panel VF 8/18Q Acoustic fleece, white	Perforated area: 19.8 % Mass: 8.0 kg/m ²	32 pcs.
	7151109110	Thermotec panel VF 12/25Q Acoustic fleece, black	1200 x 2000 x 10.0 mm	76.80 m ²
	7151109120	Thermotec panel VF 12/25Q Acoustic fleece, white	Perforated area: 23.0 % Mass: 7.7 kg/m ²	32 pcs.
	7151110110	Thermotec panel VF 8/15/20R Acoustic fleece, black	1200 x 2000 x 10.0 mm	76.80 m ² *
	7151110120	Thermotec panel VF 8/15/20R Acoustic fleece, white	Perforated area: 9.5 % Mass: 9.1 kg/m ²	32 pcs.
	7151111110	Thermotec panel VF 12/20/35R Acoustic fleece, black	1200 x 2000 x 10.0 mm	76.80 m ² *
	7151111120	Thermotec panel VF 12/20/35R Acoustic fleece, white	Perforated area: 11.0 % Mass: 8.9 kg/m ²	32 pcs.
	7151112110	Thermotec panel VF 5/82/15.4SL Acoustic fleece, black	1186 x 1984 x 10.0 mm	75.20 m ²
	7151112120	Thermotec panel VF 5/82/15.4SL Acoustic fleece, white	Perforated area: 21.5 % Mass: 7.9 kg/m ²	32 pcs.

*Note: Despite being perforated irregularly, random perforation panels still yield a certain linear layout as the abutting panel edges must be non-perforated in any case. This is unavoidable and independent of the workmanship of the specialist contractor.

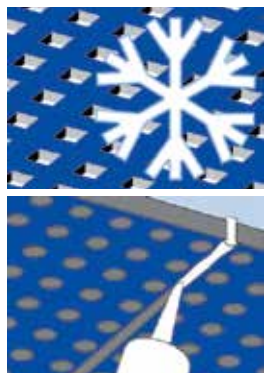

Compound Seam system VoglThermotecplatten® are perforated ceiling panels with high acoustic performance, a defined thermal conductivity of $\lambda \geq 0.25$ and air purification effect.









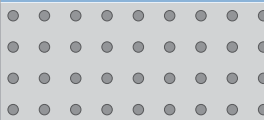
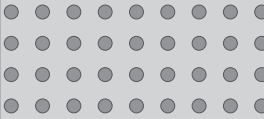

Black or white acoustic fleece backing (other fleece colours on request).

Other available options: VoglThermotec panels with non-perforated edges, block perforation, applications, manufacture in accordance with customer designs and ceiling plans.

For the screwing, we recommend art.no. 52150000 "perforated panel screw gold TB 23".

Standards: EN 14190 "Gypsum plasterboard products from reprocessing"
Material class: A2-s1, d0 (non-flammable) according to EN 13501
Long edge: SK (sharp-edged)
Short edge: SK (sharp-edged)



Illustration	Item number	Description	Details	m ² /pallet Panels/pallet
	7161101110	Thermotec panel SF 6/18R Acoustic fleece, black	1188 x 1998 x 10.0 mm	75.84 m ²
	7161101120	Thermotec panel SF 6/18R Acoustic fleece, white	Perforated area: 8.7 % Mass: 9.1 kg/m ²	32 pcs.
	7161102110	Thermotec panel SF 8/18R Acoustic fleece, black	1188 x 1998 x 10.0 mm	75.84 m ²
	7161102120	Thermotec panel SF 8/18R Acoustic fleece, white	Perforated area: 15.5 % Mass: 8.5 kg/m ²	32 pcs.
	7161103110	Thermotec panel SF 10/23R Acoustic fleece, black	1196 x 2001 x 10.0 mm	76.48 m ²
	7161103120	Thermotec panel SF 10/23R Acoustic fleece, white	Perforated area: 14.8 % Mass: 8.5 kg/m ²	32 pcs.
	7161104110	Thermotec panel SF 12/25R Acoustic fleece, black	1200 x 2000 x 10.0 mm	76.80 m ²
	7161104120	Thermotec panel SF 12/25R Acoustic fleece, white	Perforated area: 18.1 % Mass: 8.2 kg/m ²	32 pcs.
	7161105110	Thermotec panel SF 15/30R Acoustic fleece, black	1200 x 1980 x 10.0 mm	76.16 m ²
	7161105120	Thermotec panel SF 15/30R Acoustic fleece, white	Perforated area: 19.6 % Mass: 8.0 kg/m ²	32 pcs.
	7161106110	Thermotec panel SF 8/12/50R Acoustic fleece, black	1200 x 2000 x 10.0 mm	76.80 m ²
	7161106120	Thermotec panel SF 8/12/50R Acoustic fleece, white	Perforated area: 13.1 % Mass: 8.7 kg/m ²	32 pcs.
	7161107110	Thermotec panel SF 12/20/66R Acoustic fleece, black	1188 x 1980 x 10.0 mm	75.20 m ²
	7161107120	Thermotec panel SF 12/20/66R Acoustic fleece, white	Perforated area: 19.6 % Mass: 8.0 kg/m ²	32 pcs.
	7161108110	Thermotec panel SF 8/18Q Acoustic fleece, black	1188 x 1998 x 10.0 mm	75.84 m ²
	7161108120	Thermotec panel SF 8/18Q Acoustic fleece, white	Perforated area: 19.8 % Mass: 8.0 kg/m ²	32 pcs.
	7161109110	Thermotec panel SF 12/25Q Acoustic fleece, black	1200 x 2000 x 10.0 mm	76.80 m ²
	7161109120	Thermotec panel SF 12/25Q Acoustic fleece, white	Perforated area: 23.0 % Mass: 7.7 kg/m ²	32 pcs.
	7161110110	Thermotec panel SF 8/15/20R Acoustic fleece, black	1200 x 2000 x 10.0 mm	76.80 m ² *
	7161110120	Thermotec panel SF 8/15/20R Acoustic fleece, white	Perforated area: 9.5 % Mass: 9.1 kg/m ²	32 pcs.
	7161111110	Thermotec panel SF 12/20/66R Acoustic fleece, black	1200 x 2000 x 10.0 mm	76.80 m ² *
	7161111120	Thermotec panel SF 12/20/66R Acoustic fleece, white	Perforated area: 11.0 % Mass: 8.9 kg/m ²	32 pcs.

*Note: Despite being perforated irregularly, random perforation panels still yield a certain linear layout as the abutting panel edges must be non-perforated in any case. This is unavoidable and independent of the workmanship of the specialist contractor.

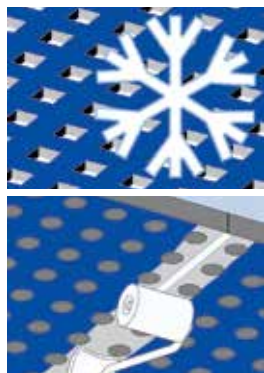

Vog|Fuge® system Vog|Thermotecplatten® PLUS are perforated ceiling panels with high acoustic performance, defined heat conductivity $\lambda \geq 0.52$ and air purification effect.

Black or white acoustic fleece backing (other fleece colours on request), all sides sharp-edged with undercut for installation using the quickest and most secure edge to edge laying principle.









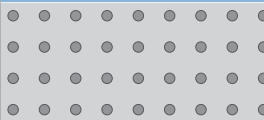
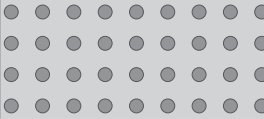

Other available options: Vog|Thermotec panels with non-perforated edges, block perforation, applications, manufacture in accordance with customer designs and ceiling plans.

Delivery includes Vog|Fuge® system kit with liquid glue (without screws).

For the screwing, we recommend art.no. 52150000 "perforated panel screw, gold, TB 23".

Standards: EN 14190 "Gypsum plasterboard products from reprocessing"
Material class: A2-s1, d0 (non-flammable) according to EN 13501
Long edge: SK (sharp-edged)
Short edge: SK (sharp-edged)



Illustration	Item number	Description	Details	m ² /pallet Panels/pallet
	7371101110	Acoustic design panel PLUS VF 6/18R Acoustic fleece, black	1188 x 1998 x 10.0 mm	75.84 m ²
	7371101120	Acoustic design panel PLUS VF 6/18R Acoustic fleece, white	Perforated area: 8.7 % Mass: 9.1 kg/m ²	32 pcs.
	7371102110	Acoustic design panel PLUS VF 8/18R Acoustic fleece, black	1188 x 1998 x 10.0 mm	75.84 m ²
	7371102120	Acoustic design panel PLUS VF 8/18R Acoustic fleece, white	Perforated area: 15.5 % Mass: 8.5 kg/m ²	32 pcs.
	7371103110	Acoustic design panel PLUS VF 10/23R Acoustic fleece, black	1196 x 2001 x 10.0 mm	76.48 m ²
	7371103120	Acoustic design panel PLUS VF 10/23R Acoustic fleece, white	Perforated area: 14.8 % Mass: 8.5 kg/m ²	32 pcs.
	7371104110	Acoustic design panel PLUS VF 12/25R Acoustic fleece, black	1200 x 2000 x 10.0 mm	76.80 m ²
	7371104120	Acoustic design panel PLUS VF 12/25R Acoustic fleece, white	Perforated area: 18.1 % Mass: 8.2 kg/m ²	32 pcs.
	7371105110	Acoustic design panel PLUS VF 15/30R Acoustic fleece, black	1200 x 1980 x 10.0 mm	76.16 m ²
	7371105120	Acoustic design panel PLUS VF 15/30R Acoustic fleece, white	Perforated area: 19.6 % Mass: 8.0 kg/m ²	32 pcs.
	7371106110	Acoustic design panel PLUS VF 8/12/50R Acoustic fleece, black	1200 x 2000 x 10.0 mm	76.80 m ²
	7371106120	Acoustic design panel PLUS VF 8/12/50R Acoustic fleece, white	Perforated area: 13.1 % Mass: 8.7 kg/m ²	32 pcs.
	7371107110	Acoustic design panel PLUS VF 12/20/66R Acoustic fleece, black	1188 x 1980 x 10.0 mm	75.20 m ²
	7371107120	Acoustic design panel PLUS VF 12/20/66R Acoustic fleece, white	Perforated area: 19.6 % Mass: 8.0 kg/m ²	32 pcs.
	7371108110	Acoustic design panel PLUS VF 8/18Q Acoustic fleece, black	1188 x 1998 x 10.0 mm	75.84 m ²
	7371108120	Acoustic design panel PLUS VF 8/18Q Acoustic fleece, white	Perforated area: 19.8 % Mass: 8.0 kg/m ²	32 pcs.
	7371109110	Acoustic design panel PLUS VF 12/25Q Acoustic fleece, black	1200 x 2000 x 10.0 mm	76.80 m ²
	7371109120	Acoustic design panel PLUS VF 12/25Q Acoustic fleece, white	Perforated area: 23.0 % Mass: 7.7 kg/m ²	32 pcs.
	7371110110	Acoustic design panel PLUS VF 8/15/20R Acoustic fleece, black	1200 x 2000 x 10.0 mm	76.80 m ² *
	7371110120	Acoustic design panel PLUS VF 8/15/20R Acoustic fleece, white	Perforated area: 9.5 % Mass: 9.1 kg/m ²	32 pcs.
	7371111110	Acoustic design panel PLUS VF 12/20/35R Acoustic fleece, black	1200 x 2000 x 10.0 mm	76.80 m ² *
	7371111120	Acoustic design panel PLUS VF 12/20/35R Acoustic fleece, white	Perforated area: 11.0 % Mass: 8.9 kg/m ²	32 pcs.

*Note: Despite being perforated irregularly, random perforation panels still yield a certain linear layout as the abutting panel edges must be non-perforated in any case. This is unavoidable and independent of the workmanship of the specialist contractor.

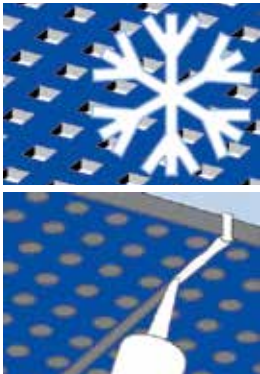

Compound Seam system VoglThermotecplatten® PLUS are perforated ceiling panels containing graphite, with high acoustic performance, a defined thermal conductivity of $\lambda \geq 0.52$ and air purification effect.



Black or white acoustic fleece backing (other fleece colours on request).

Other available options: VoglThermotec panels with non-perforated edges, block perforation, applications, manufacture in accordance with customer designs and ceiling plans.

For the screwing, we recommend art.no. 52150000 "perforated panel screw gold TB 23".

Standards: EN 14190 "Gypsum plasterboard products from reprocessing"
Material class: A2-s1, d0 (non-flammable) according to EN 13501
Long edge: SK (sharp-edged)
Short edge: SK (sharp-edged)

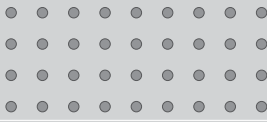
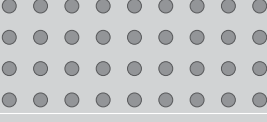
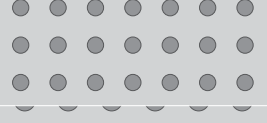
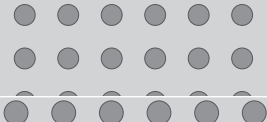
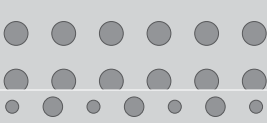
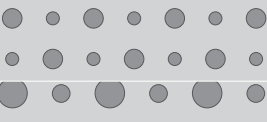
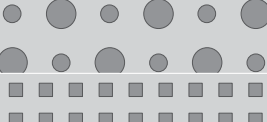

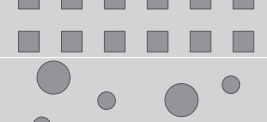
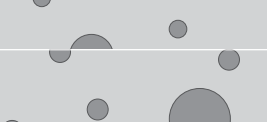
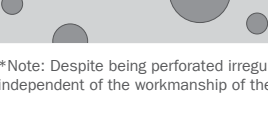
Illustration	Item number	Description	Details	m ² /pallet Panels/pallet
	7381101110	Thermotec panel PLUS SF 6/18R Acoustic fleece, black	1188 x 1998 x 10.0 mm	75.84 m ²
	7381101120	Thermotec panel PLUS SF 6/18R Acoustic fleece, white	Perforated area: 8.7 % Mass: 9.1 kg/m ²	32 pcs.
	7381102110	Thermotec panel PLUS SF 8/18R Acoustic fleece, black	1188 x 1998 x 10.0 mm	75.84 m ²
	7381102120	Thermotec panel PLUS SF 8/18R Acoustic fleece, white	Perforated area: 15.5 % Mass: 8.5 kg/m ²	32 pcs.
	7381103110	Thermotec panel PLUS SF 10/23R Acoustic fleece, black	1196 x 2001 x 10.0 mm	76.48 m ²
	7381103120	Thermotec panel PLUS SF 10/23R Acoustic fleece, white	Perforated area: 14.8 % Mass: 8.5 kg/m ²	32 pcs.
	7381104110	Thermotec panel PLUS SF 12/25R Acoustic fleece, black	1200 x 2000 x 10.0 mm	76.80 m ²
	7381104120	Thermotec panel PLUS SF 12/25R Acoustic fleece, white	Perforated area: 18.1 % Mass: 8.2 kg/m ²	32 pcs.
	7381105110	Thermotec panel PLUS SF 15/30R Acoustic fleece, black	1200 x 1980 x 10.0 mm	76.16 m ²
	7381105120	Thermotec panel PLUS SF 15/30R Acoustic fleece, white	Perforated area: 19.6 % Mass: 8.0 kg/m ²	32 pcs.
	7381106110	Thermotec panel PLUS SF 8/12/50R Acoustic fleece, black	1200 x 2000 x 10.0 mm	76.80 m ²
	7381106120	Thermotec panel PLUS SF 8/12/50R Acoustic fleece, white	Perforated area: 13.1 % Mass: 8.7 kg/m ²	32 pcs.
	7381107110	Thermotec panel PLUS SF 12/20/66R Acoustic fleece, black	1188 x 1980 x 10.0 mm	75.20 m ²
	7381107120	Thermotec panel PLUS SF 12/20/66R Acoustic fleece, white	Perforated area: 19.6 % Mass: 8.0 kg/m ²	32 pcs.
	7381108110	Thermotec panel PLUS SF 8/18Q Acoustic fleece, black	1188 x 1998 x 10.0 mm	75.84 m ²
	7381108120	Thermotec panel PLUS SF 8/18Q Acoustic fleece, white	Perforated area: 19.8 % Mass: 8.0 kg/m ²	32 pcs.
	7381109110	Thermotec panel PLUS SF 12/25Q Acoustic fleece, black	1200 x 2000 x 10.0 mm	76.80 m ²
	7381109120	Thermotec panel PLUS SF 12/25Q Acoustic fleece, white	Perforated area: 23.0 % Mass: 7.7 kg/m ²	32 pcs.
	7381110110	Thermotec panel PLUS SF 8/15/20R Acoustic fleece, black	1200 x 2000 x 10.0 mm	76.80 m ² *
	7381110120	Thermotec panel PLUS SF 8/15/20R Acoustic fleece, white	Perforated area: 9.5 % Mass: 9.1 kg/m ²	32 pcs.
	7381111110	Thermotec panel PLUS SF 12/20/35R Acoustic fleece, black	1200 x 2000 x 10.0 mm	76.80 m ² *
	7381111120	Thermotec panel PLUS SF 12/20/35R Acoustic fleece, white	Perforated area: 11.0 % Mass: 8.9 kg/m ²	32 pcs.

*Note: Despite being perforated irregularly, random perforation panels still yield a certain linear layout as the abutting panel edges must be non-perforated in any case. This is unavoidable and independent of the workmanship of the specialist contractor.

Focused on colour to the very core

Colours influence our perception of rooms and our sense of wellbeing, while texture creates charismatic surfaces. Colour can be used in interior design to significantly improve the living and comfort factor. Vogl Colour Panels allow you to add colourful accents precisely and easily.

Conventional methods for painting perforated ceilings disrupt the texture since the holes become clogged with paint. Refinishing the perforation texture is very time consuming and tedious.

In Vogl Colour Panels, the inner surfaces of the perforation are included in the factory colour treatment. This ensures high-quality and homogenous colouration.

Putting colour into the picture

The unique prefabrication offers decisive advantages:

- Even colouration of the inner surfaces of the perforation
- Available in many shades of colour
- No time-consuming reworking after painting

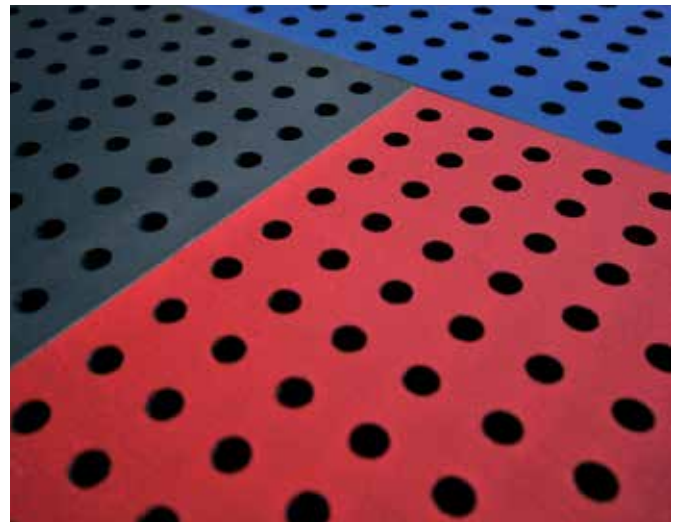
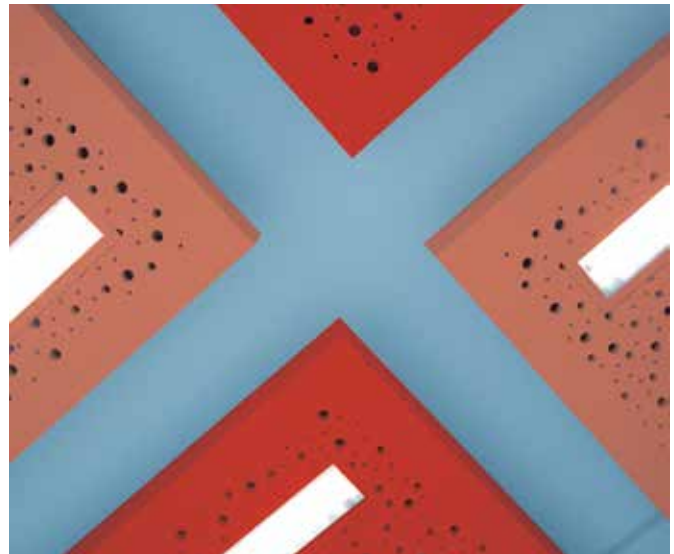

Vogl Colour Panels offer the possibility of factory-applied or on-site colouring with colour combinations for finishing coat, inner perforation and fleece colour.

The finishing coat is always applied by the painter on-site.

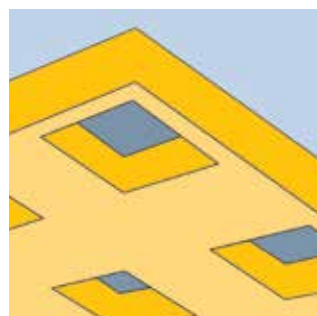

Benefits of the VoglColorplatte®:

- Perfectly sealed surfaces and properly coloured inner perforation surfaces
- Enormous time saving due to elimination of several work steps
- Satisfies highest aesthetic demands

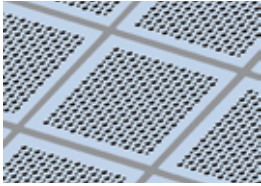

Vogl Ceiling Tiles are accessible, perforated ceiling panels with high acoustic performance for installation into T-profile systems.

The black acoustic fleece lining on the back (other colours on request) satisfies the highest demands on sound absorption.

Vogl Ceiling Tiles come with a pure white finishing coat (similar to RAL 9010).

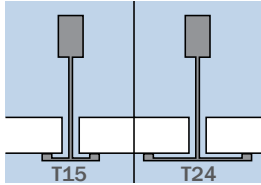

Installation system: Basic (T15/T24) exposed grid
Standards: EN 14190 "Gypsum plasterboard products from reprocessing"
Material class: A2-s1, d0 (non-combustible) according to EN 13501
Long edge: SK (sharp-edged)
Short edge: SK (sharp-edged)



Illustration	Item number	Description	Details	Pcs./PU PU/pallet
	7301100000	GP-K Basic 600 T15/T24 smooth	600 x 600 x 12.5 mm	6 pcs.
	7301200000	GP-K Basic 625 T15/T24 smooth	625 x 625 x 12.5 mm	28 PU
	7301101110	GP-K Basic 600 T15/T24 6/18R AVS Acoustic fleece, black	600 x 600 x 12.5 mm	6 pcs.
	7301201110	GP-K Basic 625 T15/T24 6/18R AVS Acoustic fleece, black	625 x 625 x 12.5 mm	28 PU
	7301102110	GP-K Basic 600 T15/T24 8/18R AVS Acoustic fleece, black	600 x 600 x 12.5 mm	6 pcs.
	7301202110	GP-K Basic 625 T15/T24 8/18R AVS Acoustic fleece, black	625 x 625 x 12.5 mm	28 PU
	7301107110	GP-K Basic 600 T15/T24 12/20/66R AVS Acoustic fleece, black	600 x 600 x 12.5 mm	6 pcs.
	7301207110	GP-K Basic 625 T15/T24 12/20/66R AVS Acoustic fleece, black	625 x 625 x 12.5 mm	28 PU
	7301108110	GP-K Basic 600 T15/T24 8/18Q AVS Acoustic fleece, black	600 x 600 x 12.5 mm	6 pcs.
	7301208110	GP-K Basic 625 T15/T24 8/18Q AVS Acoustic fleece, black	625 x 625 x 12.5 mm	28 PU
	7301109110	GP-K Basic 600 T15/T24 12/25Q AVS Acoustic fleece, black	600 x 600 x 12.5 mm	6 pcs.
	7301209110	GP-K Basic 625 T15/T24 12/25Q AVS Acoustic fleece, black	625 x 625 x 12.5 mm	28 PU
	7301112110	GP-K Basic 600 T15/T24 5/82/15.4SL AVS Acoustic fleece, black	600 x 600 x 12.5 mm	6 pcs.
	7301212110	GP-K Basic 625 T15/T24 5/82/15.4SL AVS Acoustic fleece, black	625 x 625 x 12.5 mm	28 PU
	7301114110	GP-K Basic 600 T15/T24 3.5/9Q AVS Acoustic fleece, black	600 x 600 x 12.5 mm	6 pcs.
	7301214110	GP-K Basic 625 T15/T24 3.5/9Q AVS Acoustic fleece, black	625 x 625 x 12.5 mm	28 PU

Further perforation patterns/dimensions available on request

Product Range

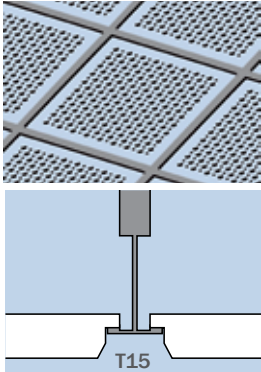

Vogl Ceiling Tiles are accessible, perforated ceiling panels with high acoustic performance for installation into T-profile systems.

The black acoustic fleece lining on the back (other colours on request) satisfies the highest demands on sound absorption.

Vogl Ceiling Tiles come with a pure white finishing coat (similar to RAL 9010).

Installation system: Excellent (T15) partially concealed installation
Standards: EN 14190 "Gypsum plasterboard products from reprocessing"
Material class: A2-s1, d0 (non-combustible) according to EN 13501
Long edge: FK T15 (chamfered), type Excellent
Short edge: FK T15 (chamfered), type Excellent



Illustration	Item number	Description	Details	Pcs./PU PU/pallet
	7311300000	GP-K Excellent 600 T15 smooth	600 x 600 x 12.5 mm	6 pcs.
	7311500000	GP-K Excellent 625 T15 smooth	625 x 625 x 12.5 mm	28 PU
	7311301110	GP-K Excellent 600 T15 6/18R AVS Acoustic fleece, black	600 x 600 x 12.5 mm	6 pcs.
	7311501110	GP-K Excellent 625 T15 6/18R AVS Acoustic fleece, black	625 x 625 x 12.5 mm	28 PU
	7311302110	GP-K Excellent 600 T15 8/18R AVS Acoustic fleece, black	600 x 600 x 12.5 mm	6 pcs.
	7311502110	GP-K Excellent 625 T15 8/18R AVS Acoustic fleece, black	625 x 625 x 12.5 mm	28 PU
	7311307110	GP-K Excellent 600 T15 12/20/66R AVS Acoustic fleece, black	600 x 600 x 12.5 mm	6 pcs.
	7311507110	GP-K Excellent 625 T15 12/20/66R AVS Acoustic fleece, black	625 x 625 x 12.5 mm	28 PU
	7311308110	GP-K Excellent 600 T15 8/18Q AVS Acoustic fleece, black	600 x 600 x 12.5 mm	6 pcs.
	7311508110	GP-K Excellent 625 T15 8/18Q AVS Acoustic fleece, black	625 x 625 x 12.5 mm	28 PU
	7311308110	GP-K Excellent 600 T15 12/25Q AVS Acoustic fleece, black	600 x 600 x 12.5 mm	6 pcs.
	7311508110	GP-K Excellent 625 T15 12/25Q AVS Acoustic fleece, black	625 x 625 x 12.5 mm	28 PU
	7311312110	GP-K Excellent 600 T15 5/82/15.4SL AVS Acoustic fleece, black	600 x 600 x 12.5 mm	6 pcs.
	7311512110	GP-K Excellent 625 T15 5/82/15.4SL AVS Acoustic fleece, black	625 x 625 x 12.5 mm	28 PU
	7311314110	GP-K Excellent 600 T15 3.5/9Q AVS Acoustic fleece, black	600 x 600 x 12.5 mm	6 pcs.
	7311514110	GP-K Excellent 625 T15 3.5/9Q AVS Acoustic fleece, black	625 x 625 x 12.5 mm	28 PU
Further perforation patterns/dimensions available on request				

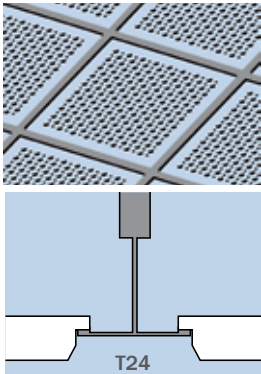

Vogl Ceiling Tiles are accessible, perforated ceiling panels with high acoustic performance for installation into T-profile systems.

The black acoustic fleece lining on the back (other colours on request) satisfies the highest demands on sound absorption.

Vogl Ceiling Tiles come with a pure white finishing coat (similar to RAL 9010).

Installation system: Excellent (T24) partially concealed installation
Standards: EN 14190 "Gypsum plasterboard products from reprocessing"
Material class: A2-s1, d0 (non-combustible) according to EN 13501
Long edge: FK T24 (chamfered), type Excellent
Short edge: FK T24 (chamfered), type Excellent



Illustration	Item number	Description	Details	Pcs./PU PU/pallet
	7311400000	GP-K Excellent 600 T24 smooth	600 x 600 x 12.5 mm	6 pcs.
	7311600000	GP-K Excellent 600 T24 smooth	625 x 625 x 12.5 mm	28 PU
	7311401110	GP-K Excellent 600 T24 6/18R AVS Acoustic fleece, black	600 x 600 x 12.5 mm	6 pcs.
	7311601110	GP-K Excellent 625 T24 6/18R AVS Acoustic fleece, black	625 x 625 x 12.5 mm	28 PU
	7311402110	GP-K Excellent 600 T24 8/18R AVS Acoustic fleece, black	600 x 600 x 12.5 mm	6 pcs.
	7311602110	GP-K Excellent 625 T24 8/18R AVS Acoustic fleece, black	625 x 625 x 12.5 mm	28 PU
	7311407110	GP-K Excellent 600 T24 12/20/66R AVS Acoustic fleece, black	600 x 600 x 12.5 mm	6 pcs.
	7311607110	GP-K Excellent 625 T24 12/20/66R AVS Acoustic fleece, black	625 x 625 x 12.5 mm	28 PU
	7311408110	GP-K Excellent 600 T24 8/18Q AVS Acoustic fleece, black	600 x 600 x 12.5 mm	6 pcs.
	7311608110	GP-K Excellent 625 T24 8/18Q AVS Acoustic fleece, black	625 x 625 x 12.5 mm	28 PU
	7311409110	GP-K Excellent 600 T24 12/25Q AVS Acoustic fleece, black	600 x 600 x 12.5 mm	6 pcs.
	7311609110	GP-K Excellent 625 T24 12/25Q AVS Acoustic fleece, black	625 x 625 x 12.5 mm	28 PU
	7311412110	GP-K Excellent 600 T24 5/82/15.4SL AVS Acoustic fleece, black	600 x 600 x 12.5 mm	6 pcs.
	7311612110	GP-K Excellent 625 T24 5/82/15.4SL AVS Acoustic fleece, black	625 x 625 x 12.5 mm	28 PU
	7311414110	GP-K Excellent 600 T24 3.5/9Q AVS Acoustic fleece, black	600 x 600 x 12.5 mm	6 pcs.
	7311614110	GP-K Excellent 625 T24 3.5/9Q AVS Acoustic fleece, black	625 x 625 x 12.5 mm	28 PU

Further perforation patterns/dimensions available on request

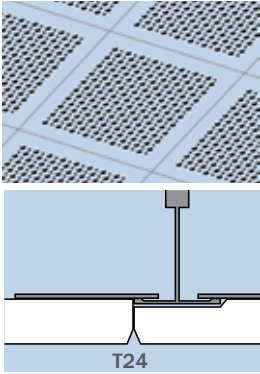

Vogl Ceiling Tiles are accessible, perforated ceiling panels with high acoustic performance for installation into T-profile systems.

The black acoustic fleece lining on the back (other colours on request) satisfies the highest demands on sound absorption.

Vogl Ceiling Tiles come with a pure white finishing coat (similar to RAL 9010).

Installation system: Premium (T24) concealed installation
Standards: EN 14190 "Gypsum plasterboard products from reprocessing"
Material class: A2-s1, d0 (non-combustible) according to EN 13501
Long edge: FK T24 (chamfered), type Premium
Short edge: FK T24 (chamfered), type Premium



Illustration	Item number	Description	Details	Pcs./PU PU/pallet
	7331400000	GP-K Premium 600 T24 smooth	600 x 600 x 12.5 mm	6 pcs.
	7331600000	GP-K Premium 625 T24 smooth	625 x 625 x 12.5 mm	28 PU
	7331401110	GP-K Premium 600 T24 6/18R AVS Acoustic fleece, black	600 x 600 x 12.5 mm	6 pcs.
	7331601110	GP-K Premium 625 T24 6/18R AVS Acoustic fleece, black	625 x 625 x 12.5 mm	28 PU
	7331402110	GP-K Premium 600 T24 8/18R AVS Acoustic fleece, black	600 x 600 x 12.5 mm	6 pcs.
	7331602110	GP-K Premium 625 T24 8/18R AVS Acoustic fleece, black	625 x 625 x 12.5 mm	28 PU
	7331407110	GP-K Premium 600 T24 12/20/66R AVS Acoustic fleece, black	600 x 600 x 12.5 mm	6 pcs.
	7331607110	GP-K Premium 625 T24 12/20/66R AVS Acoustic fleece, black	625 x 625 x 12.5 mm	28 PU
	7331408110	GP-K Premium 600 T24 8/18Q AVS Acoustic fleece, black	600 x 600 x 12.5 mm	6 pcs.
	7331608110	GP-K Premium 625 T24 8/18Q AVS Acoustic fleece, black	625 x 625 x 12.5 mm	28 PU
	7331409110	GP-K Premium 600 T24 12/25Q AVS Acoustic fleece, black	600 x 600 x 12.5 mm	6 pcs.
	7331609110	GP-K Premium 625 T24 12/25Q AVS Acoustic fleece, black	625 x 625 x 12.5 mm	28 PU
	7331412110	GP-K Premium 600 T24 5/82/15.4SL AVS Acoustic fleece, black	600 x 600 x 12.5 mm	6 pcs.
	7331612110	GP-K Premium 625 T24 5/82/15.4SL AVS Acoustic fleece, black	625 x 625 x 12.5 mm	28 PU
	7331414110	GP-K Premium 600 T24 3.5/9Q AVS Acoustic fleece, black	600 x 600 x 12.5 mm	6 pcs.
	7331614110	GP-K Premium 625 T24 3.5/9Q AVS Acoustic fleece, black	625 x 625 x 12.5 mm	28 PU

Further perforation patterns/dimensions available on request

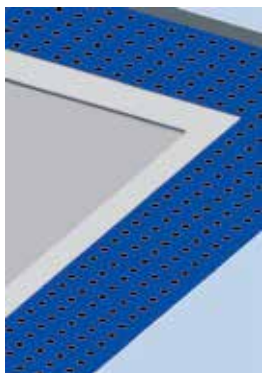

VogIToptec® acoustic plaster system panels are perforated ceiling panels with high acoustic performance (exception: type Reflexio which creates reflecting areas) for on-site lamination of the fleece plaster base (glass fibre fleece) and subsequent final coating with VogIToptec® acoustic plaster.

Acoustic fleece or foil backing, all sides sharp-edged with undercut for installation using the quickest and most secure edge to edge laying principle.

Delivery including VogIToptec® screw kit (incl. perforated panel screws SN 3.5 x 30).

Standards: EN 14190 "Gypsum plasterboard products from reprocessing"
Material class: A2-s1, d0 or B1-s1, d0 (with foil) according to EN 13501
Long edge: SK (sharp-edged)
Short edge: SK (sharp-edged)



Illustration	Item number	Description	Details	m ² /pallet Panels/pallet
	7221100010	Acoustic plaster system panel Reflexio Acoustic fleece, black	1206 x 2006 x 12.5 mm Perforated area: 0 % Mass: 10.0 kg/m ²	60.5 m ² 25 pcs.
	7221102110	Acoustic plaster system panel 8/18R Acoustic fleece, black	1194 x 2004 x 12.5 mm Perforated area: 15.4 % Mass: 8.5 kg/m ²	59.8 m ² 25 pcs.
	7221109110	Acoustic plaster system panel 12/25Q Acoustic fleece, black	1206 x 2006 x 12.5 mm Perforated area: 22.9 % Mass: 7.7 kg/m ²	60.5 m ² 25 pcs.
	7231113110	Ultracoustic panel DLV 12/25R Acoustic fleece, black	1232.5 x 1950 x 12.5 mm Perforated area: 33.9 % Mass: 6.5 kg/m ²	60.0 m ² 25 pcs.
	7221100080	Acoustic plaster system panel 12/25Q Acoustic fleece, black and foil	1206 x 2006 x 12.5 mm Perforated area: 22.9 % Mass: 7.7 kg/m ²	60.5 m ² 25 pcs.

- 1** Acoustic fleece or acoustic fleece and foil **ex factory**
- 2** VogIToptec® system panel
- 3** Plaster base fleece **installed on-site**
- 4** Acoustic plaster **installed on-site**

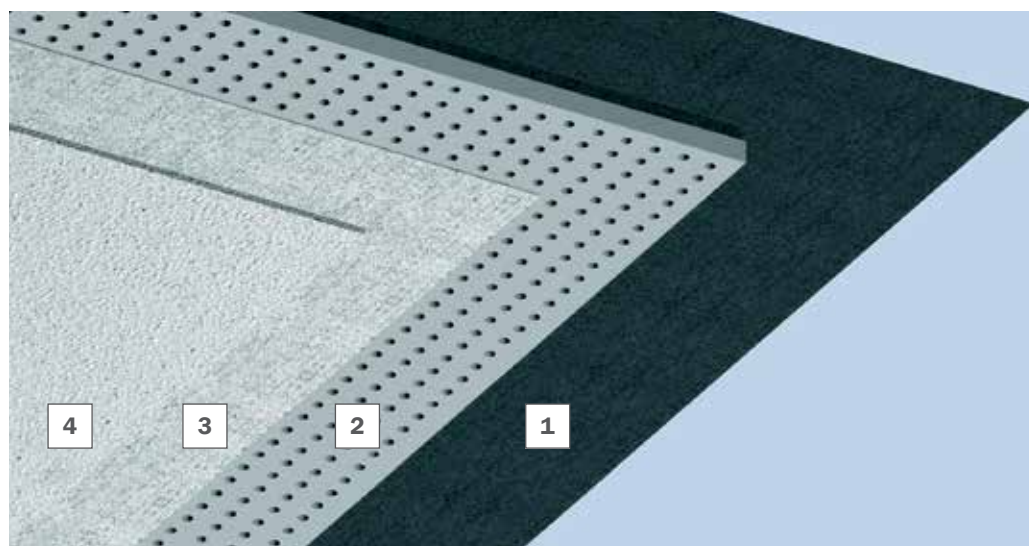

New swinging shape for ceilings

Perfectly designed Floating Ceilings lastingly enhance any conventional ceiling construction. They improve noise absorption and thus selectively contribute to improved room acoustics. Furthermore, they offer the possibility of integrating chilled ceiling floating elements and fitted ceiling components (sprinklers, illumination, ventilation, etc.) in a great variety, always easily accessible.

The Floating Ceilings are manufactured upon request within a short time of drawing approval in accordance with customer specifications, pre-assembled and - if huge in size - disassembled again into manageable segments for ease of transporting and on-site handling.

Simple installation technology assures easy handling and particularly quick processing.

Perfect design available ex factory

The unique prefabrication offers decisive advantages:

- Optimum joint appearance without visible panel edges
- Wide choice of shapes, colours and functions
- Perfect complement to old ceilings
- Easy installation
- Custom solutions can be produced at short notice
- The result is impressive:
- Perfectly prefabricated floating ceilings for direct final installation – it couldn't be any easier



Available V-grooves

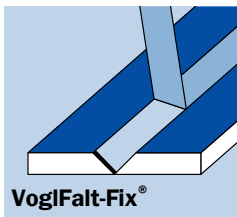

Fold Fix moulded components come flat (space-saving) and factory-supplied with Fold Fix adhesive tape.

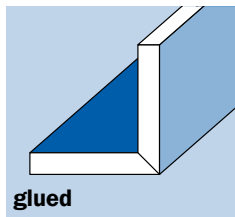

glued

Special glued moulded components come ready to install.

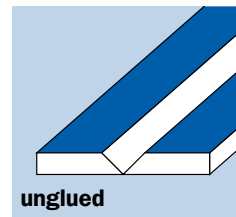

unglued

Special unglued moulded components come flat and must be assembled and glued on site.

Available angles

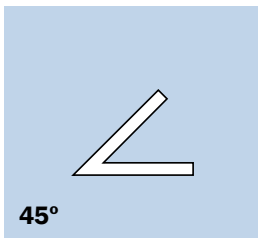

45°

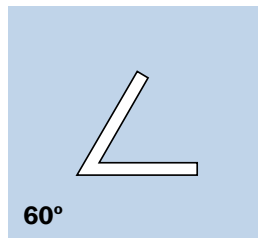

60°

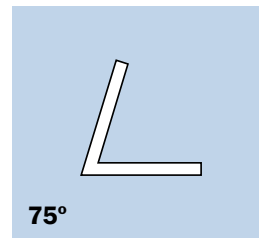

75°

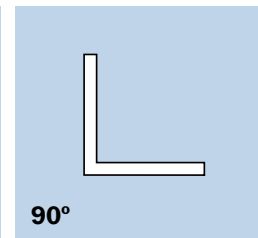

90°

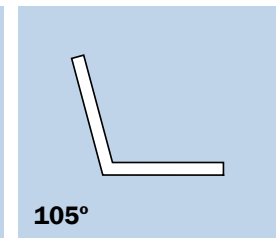

105°

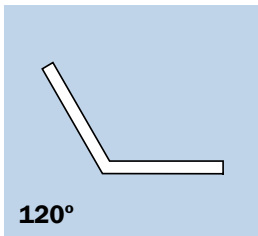

120°

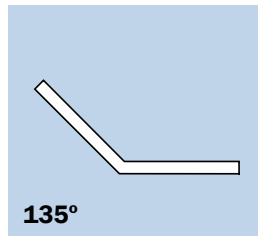

135°

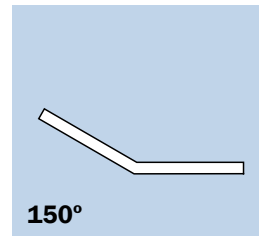

150°

Other angles on request

Available edge designs (subject to technical feasibility)

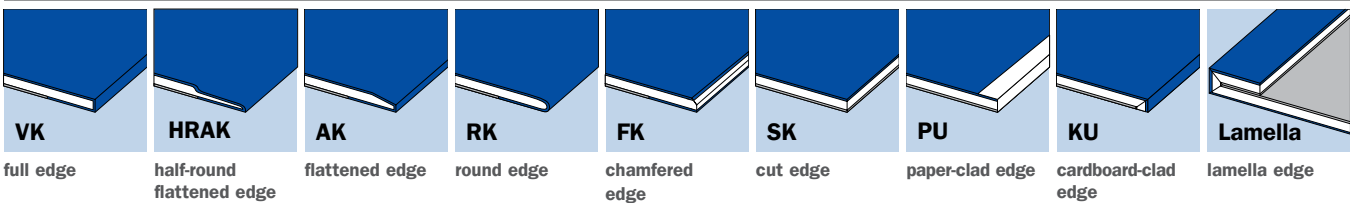

Available panel designs / thicknesses

Type	Description	Function	Thickness in mm
A	Plasterboard type A as per EN 520 Plasterboard type GKB as per DIN 18180	Standard plasterboard Note: available as Thermotec in 10 mm thickness	6.5 mm 9.5 mm 10.0 mm 12.5 mm
DF	Plasterboard type DF as per EN 520 Plasterboard type GKF as per DIN 18180	Plasterboards with improved fire behaviour	12.5 mm 15.0 mm 18.0 mm 20.0 mm 25.0 mm
DFH2	Plasterboard type DFH2 as per EN 520 Plasterboard type GKFI as per DIN 18180	Plasterboards with reduced water absorption (impregnated)	12.5 mm 15.0 mm 20.0 mm 25.0 mm

Illustration	Item number	Description	Dimensions width length thickness	m ² /pallet pcs./pallet
		Fold Fix moulded components Plasterboards cut to size with 90° V-grooves and Vogl Falt-Fix® adhesive tape	Type of panel Type "A" (EN 520) Custom dimensions and other panel types available on request	
<p>Voglfalt-Fix®</p>	75700010	Fold Fix moulded components 90° 100+200	300 x 2000 x 12.5 mm	400 m/pallet 200 pcs./pallet
	75710010	Fold Fix moulded components 90° 200+200	400 x 2000 x 12.5 mm	300 m/pallet 150 pcs./pallet
	75720010	Fold Fix moulded components 90° 300+300	600 x 2000 x 12.5 mm	200 m/pallet 100 pcs./pallet
	75730010	Fold Fix moulded components 90° 200+400	600 x 2000 x 12.5 mm	200 m/pallet 100 pcs./pallet
<div style="display: flex; justify-content: space-around;"> <div style="text-align: center;"> <p>1. Delivered flat</p> </div> <div style="text-align: center;"> <p>2. Remove cover paper</p> </div> <div style="text-align: center;"> <p>3. Press limbs firmly together</p> </div> <div style="text-align: center;"> <p>4. Done!</p> </div> </div> <p>Key advantages:</p> <ul style="list-style-type: none"> • Glueless joining of moulded components on site, no priming, no drying times • Easy on-site handling of moulded components • High adhesive strength immediately • Angle adjustment of ± 2° after adhesion • Delivered flat - less handling damage <p>Note: Fold Fix moulded components must be installed without any stresses acting upon them. The free limb must be fixated.</p>				
		GK panel strips Glued plasterboards as moving ceiling connection Long edge: SK Short edge: SK	Type of panel Type "A" (EN 520) Custom dimensions available on request	
	76000070	Panel strips (double)	50 x 2500 x 25.0 mm	1,260 m/pallet 504 pcs./pallet
	76010070	Panel strips (double)	75 x 2500 x 25.0 mm	880 m/pallet 352 pcs./pallet
	76020070	Panel strips (double)	100 x 2500 x 25.0 mm	690 m/pallet 276 pcs./pallet
	76100070	Panel strips (triple)	50 x 2500 x 37.5 mm	840 m/pallet 336 pcs./pallet
	76110070	Panel strips (triple)	75 x 2500 x 37.5 mm	560 m/pallet 224 pcs./pallet
	76120070	Panel strips (triple)	100 x 2500 x 37.5 mm	450 m/pallet 180 pcs./pallet
	76200070	Panel strips (quadruple)	50 x 2500 x 50.0 mm	600 m/pallet 240 pcs./pallet
	76210070	Panel strips (quadruple)	75 x 2500 x 50.0 mm	440 m/pallet 176 pcs./pallet
	76220070	Panel strips (quadruple)	100 x 2500 x 50.0 mm	330 m/pallet 132 pcs./pallet

Illustration	Item number	Description	Dimensions			m/pallet pcs./pallet
			width	length	thickness	
		Microslits (longitudinal slits) of type "A" plasterboards (EN 520) 12.5 mm for on-site adaptation to round components with tight radii				ME = 1 m
	74807020	Microslits (longitudinal slits)	1250 x 2000	2000	12.5 mm	Packed in bulk according to required quantity
	74817020	Microslits (longitudinal slits) Plaster strip: 5.0 mm Groove: 1.7 mm For radii \geq 80.0 mm	600 x 2000	2000	12.5 mm	

Other thicknesses, lengths and qualities on request. Longitudinal, unslit edge to the left and/or right possible on request. Custom elements possible.

Quarter shells

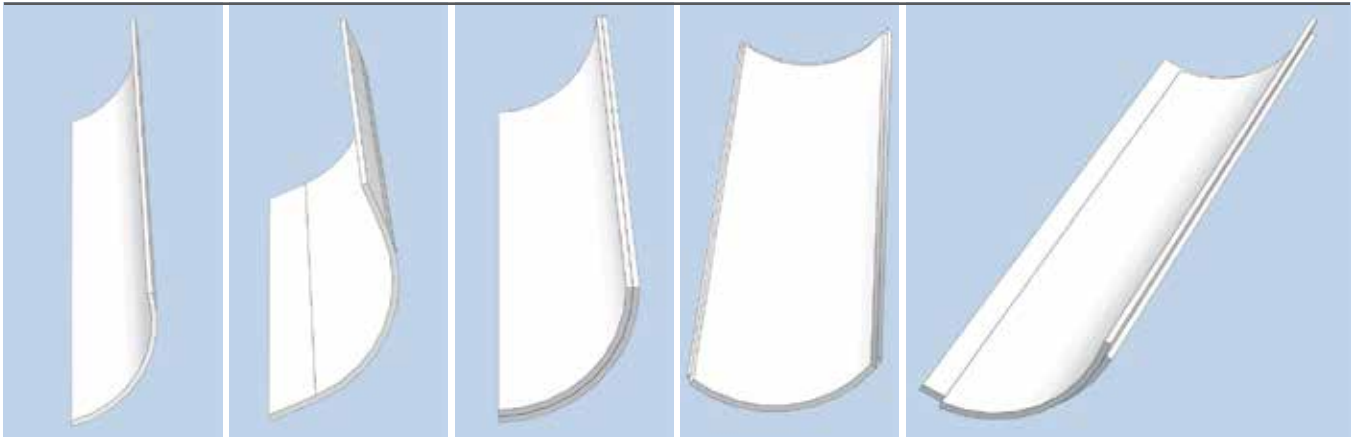

Half shells

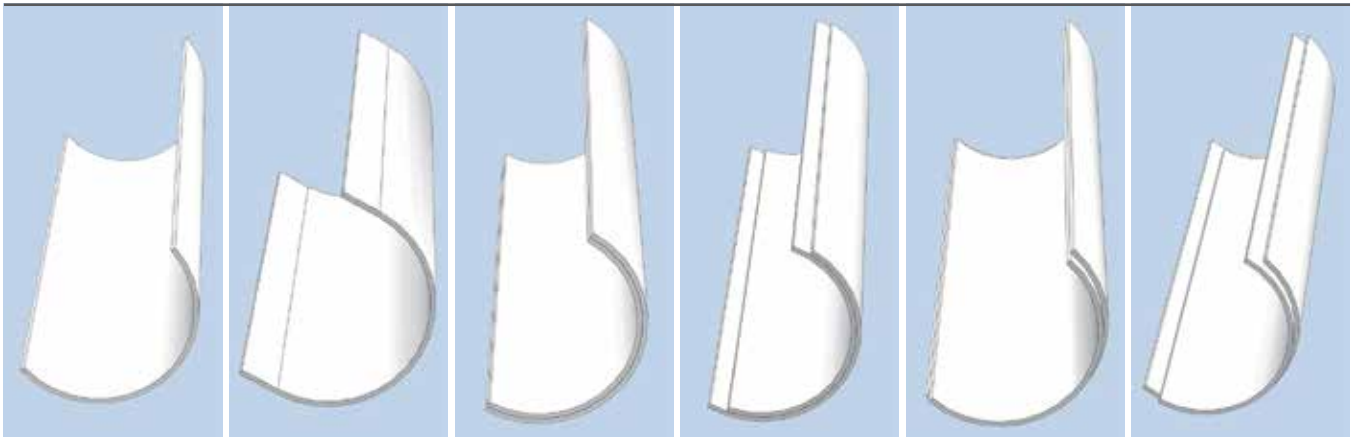

V-grooves

(S) = visible side

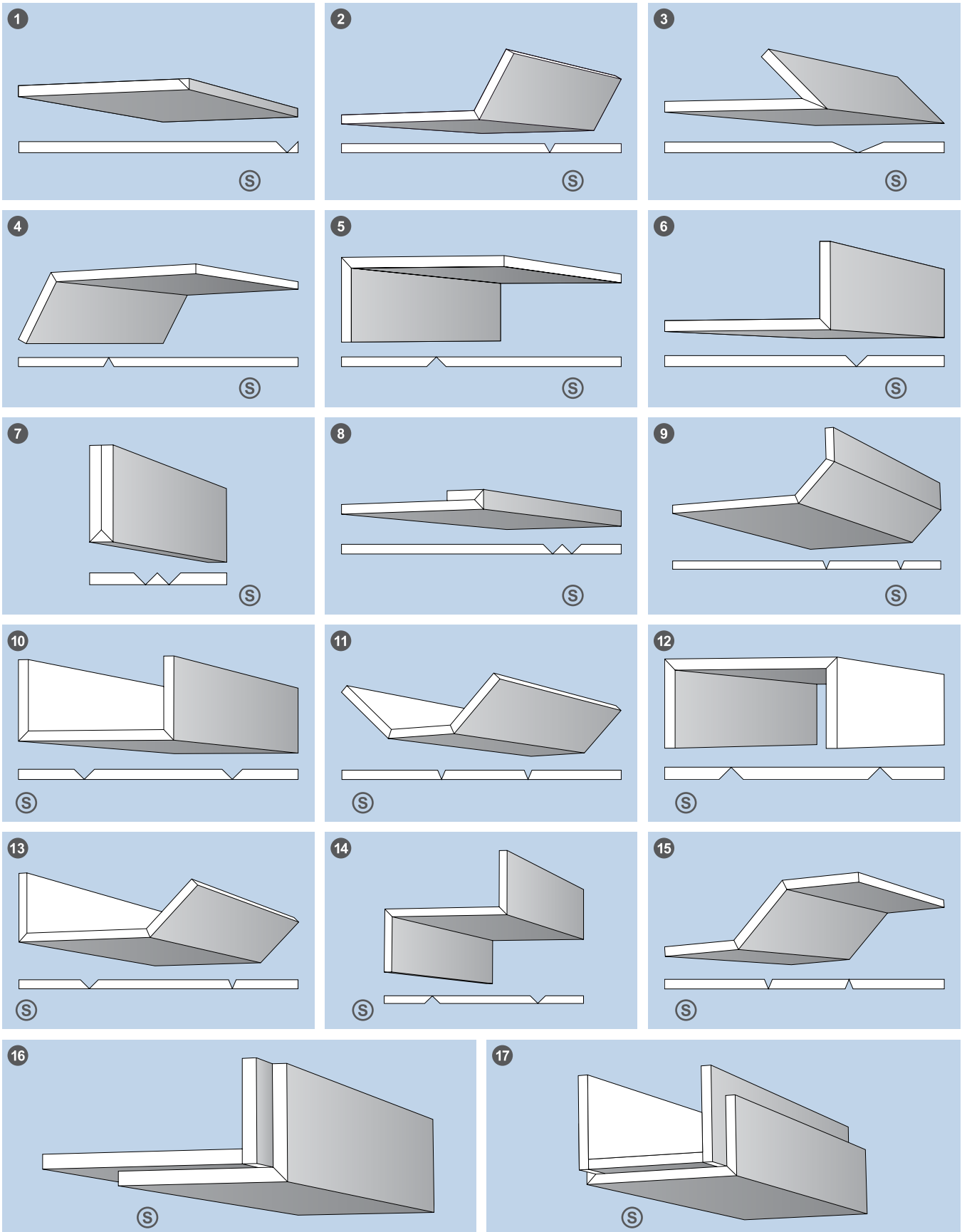

Product Range

V-grooves

Ⓢ = visible side

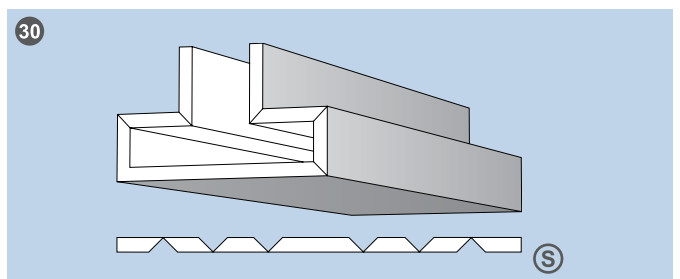
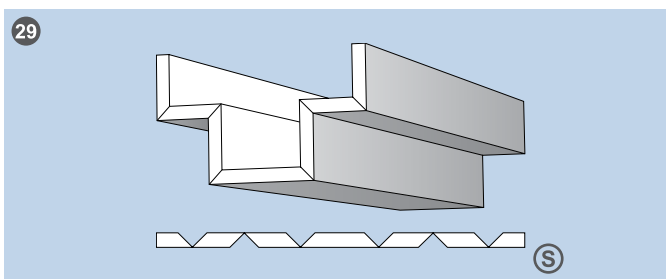
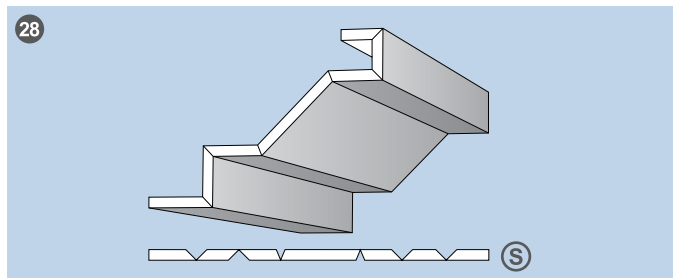
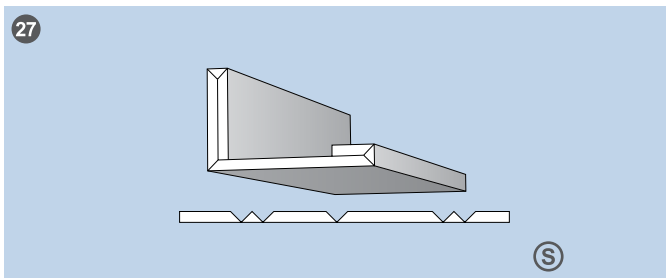
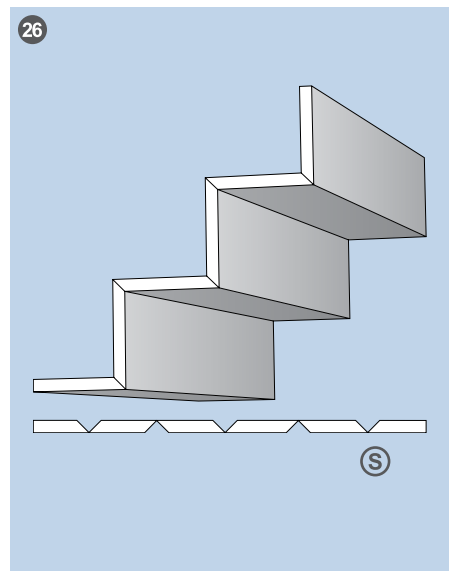
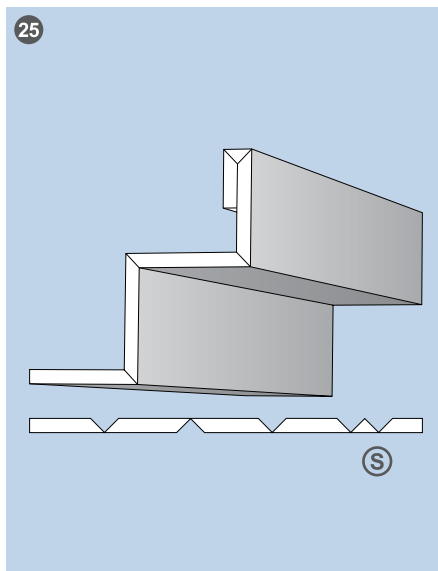
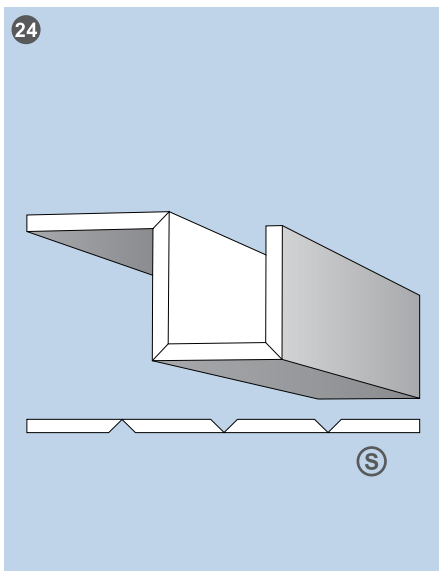
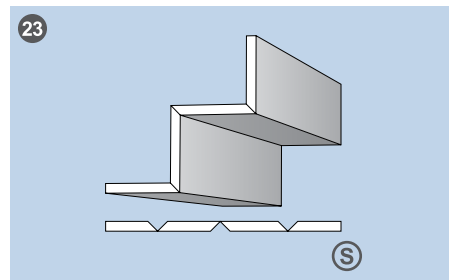
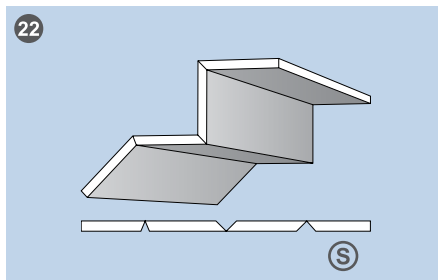
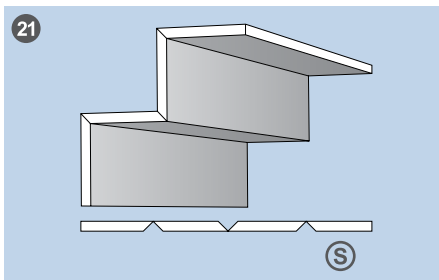
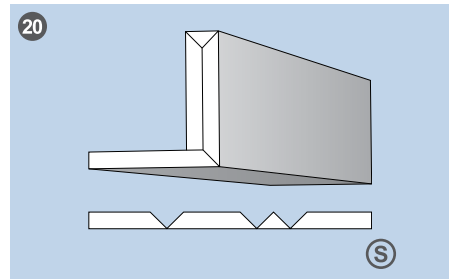
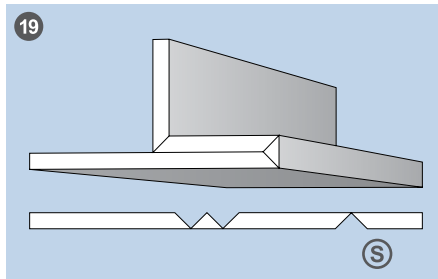
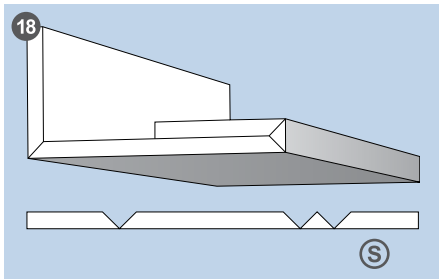

Product Range

V-grooves

Ⓢ = visible side

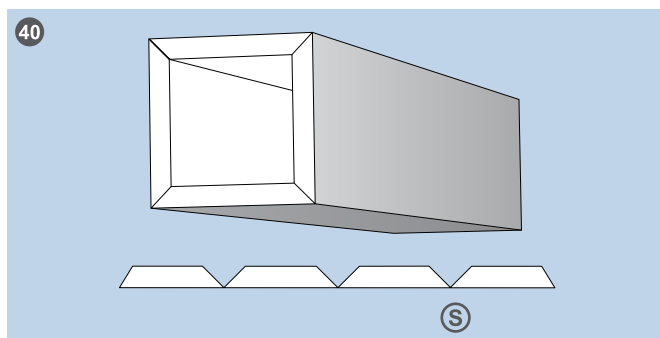
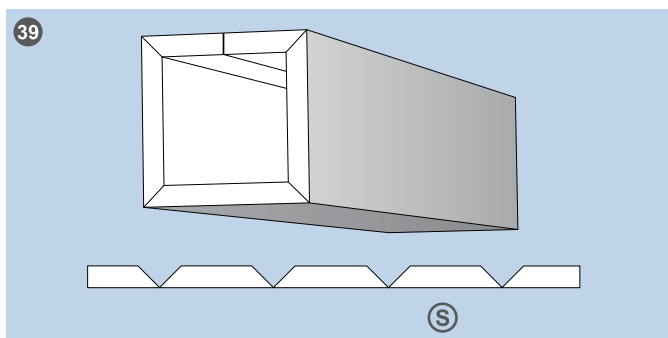
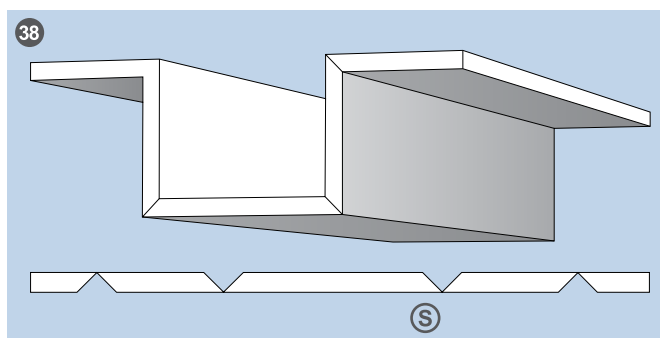
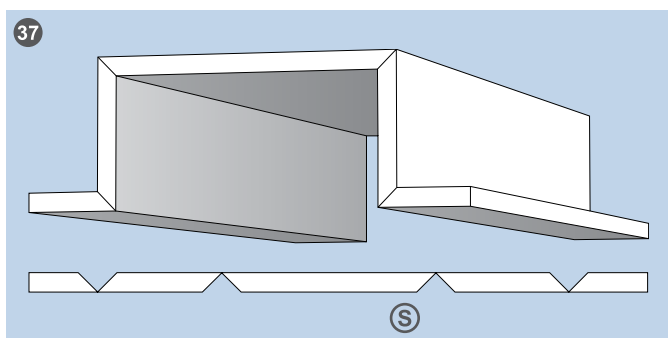
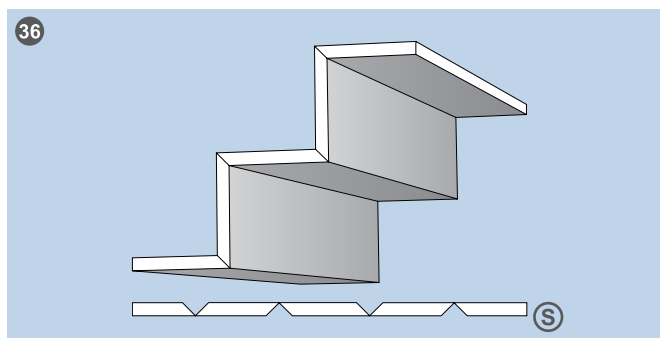
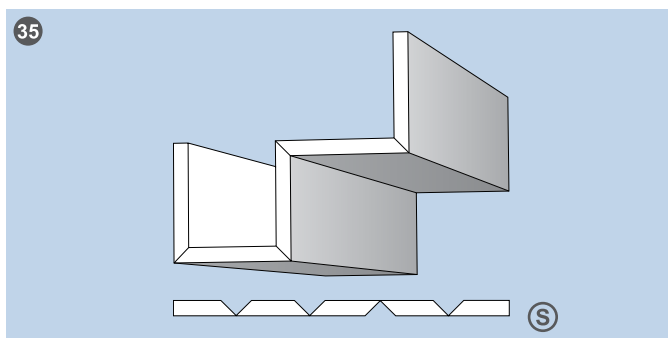
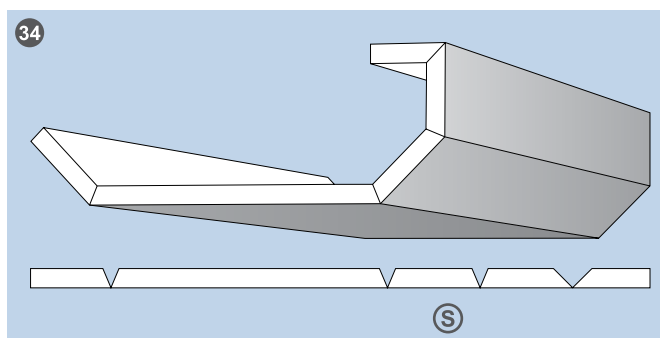
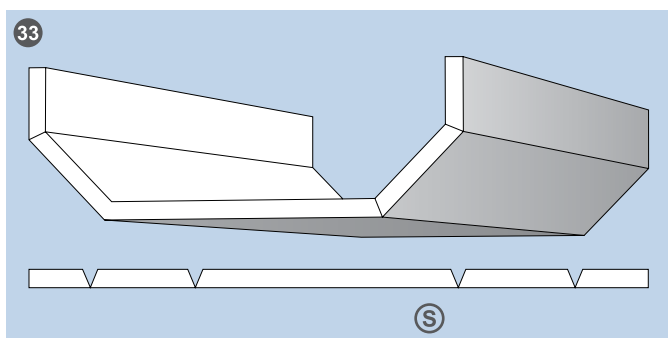
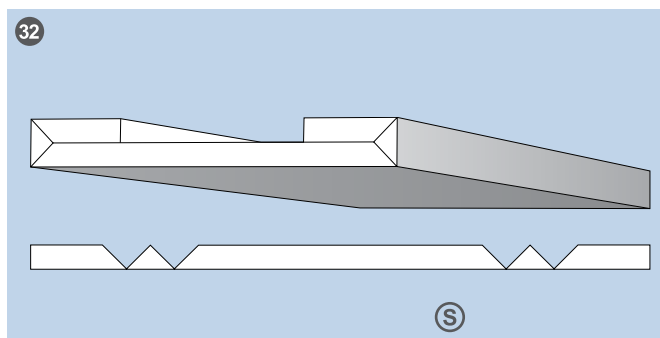
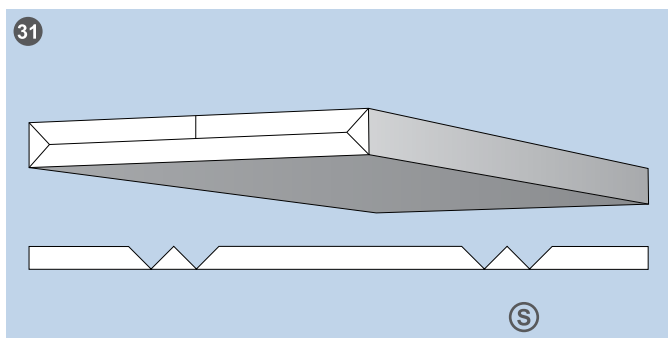

Product Range

Special elements

Product Range

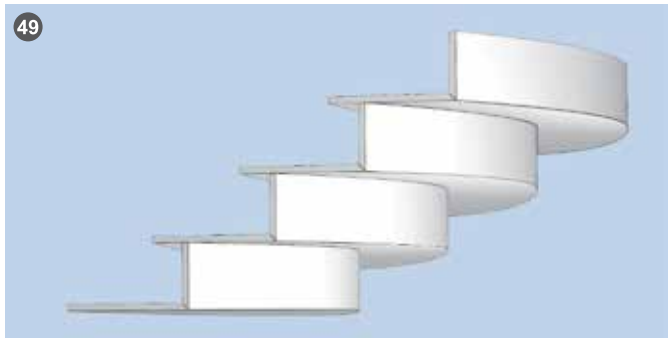
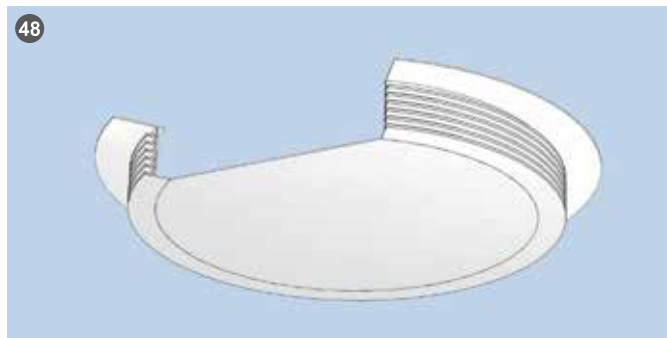
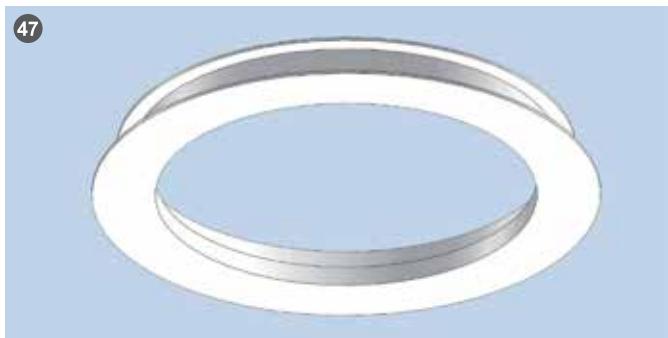
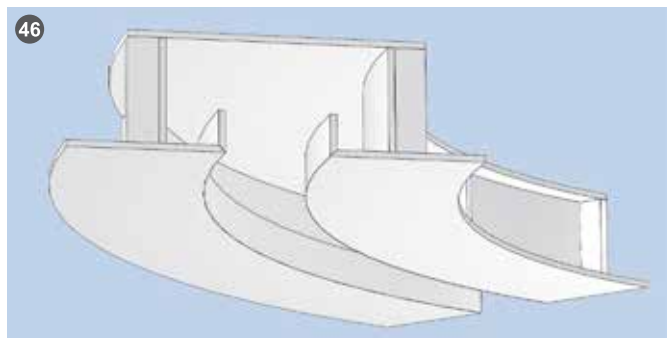
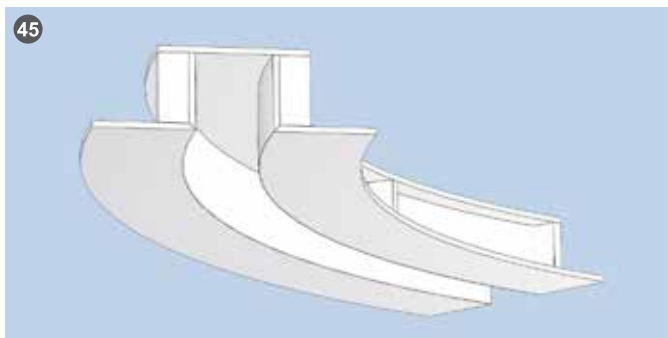
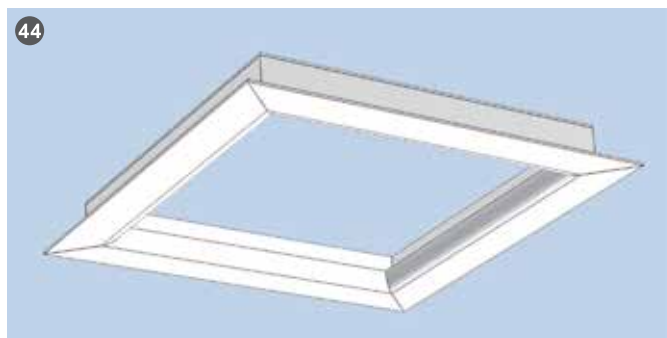
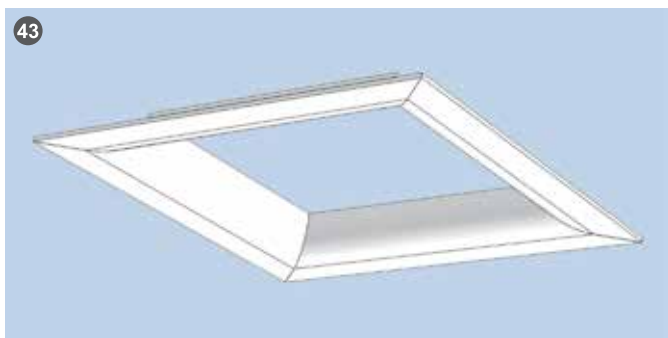
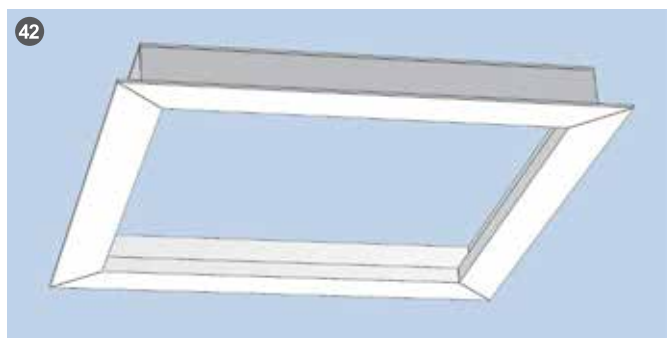
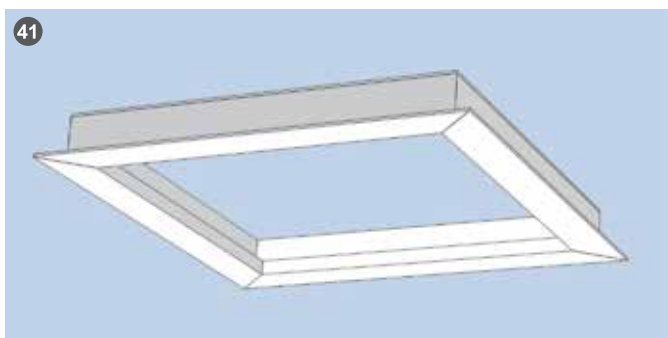

Perfect design available ex factory

Three-dimensional ceiling designs with curved components are the royal class in sophisticated interior design. Various types of arches, domes or curved segments as well as convex or concave forms require a high level of craftsmanship.

Vogl Deckensysteme achieves the basis for the complex interaction between individual steel and plaster components through comprehensive expertise and absolute precision in detail.

- Precise fitting of individual components guarantees highly aesthetic final results
- Complex two- and three dimensional shapes can be produced
- Economical installation provides an important time advantage and result reliability
- Manageable units for optimal logistics and handling on site
- Our knowledge of the manifold options of applications is the key to success, starting right at the initial planning stage
- Customised special solutions from lightweight steel construction to individual covering are realised in short time

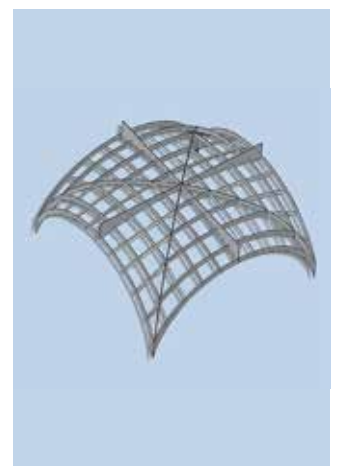

Customer drawing:

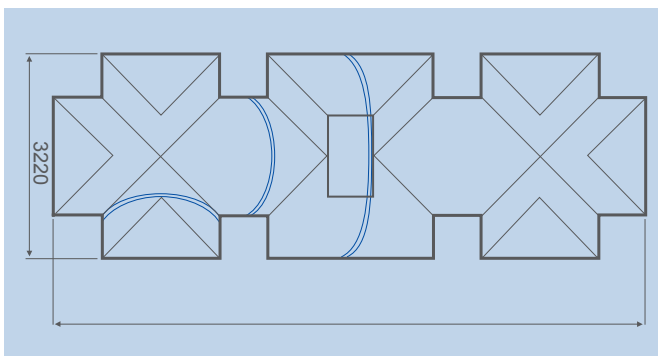

Vogl detailed drawing:

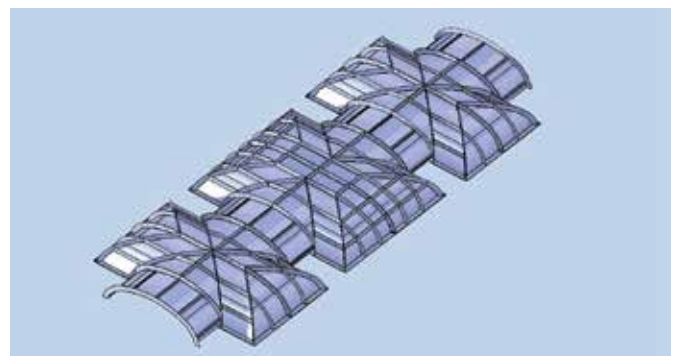

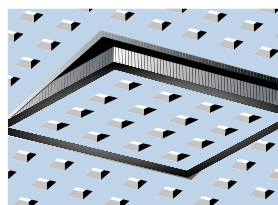

We receive the customer's drawings and develop every detail to absolute precision.

Until the complete 3D model is finished. Production then starts based on this model.

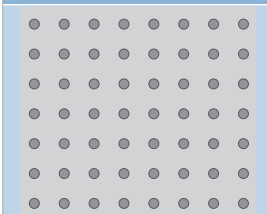
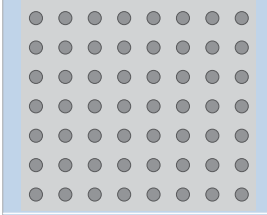
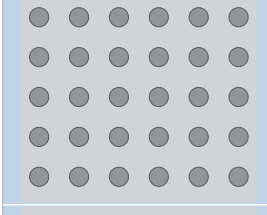
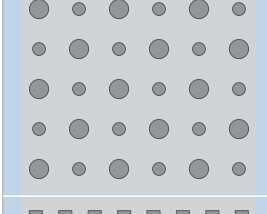
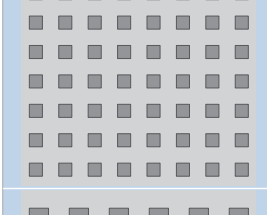
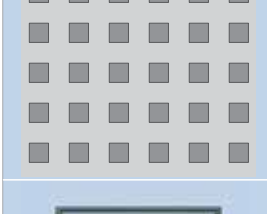

Vogl access panels are the perfect technical solution for quickly adding accessible openings into perforated ceiling areas. The perforated panel insert precisely factory-fitted into the opening frame is lined with black acoustic fleece for high acoustic performance. The specified standard articles are designed for a panel thickness of 12.5 mm.

Illustration	Item number	Description	Access opening dimensions
	84000600	Access panel, aluminium, 6/18R, black acoustic fleece	approx. 200 x 200 mm
	84000100	Access panel, aluminium, 6/18R, black acoustic fleece	approx. 300 x 300 mm
	84000200	Access panel, aluminium, 6/18R, black acoustic fleece	approx. 400 x 400 mm
	84000300	Access panel, aluminium, 6/18R, black acoustic fleece	approx. 500 x 500 mm
	84000400	Access panel, aluminium, 6/18R, black acoustic fleece	approx. 600 x 600 mm
	84000500	Access panel, aluminium, 6/18R, black acoustic fleece	approx. 400 x 600 mm
	84010600	Access panel, aluminium, 8/18R, black acoustic fleece	approx. 200 x 200 mm
	84010100	Access panel, aluminium, 8/18R, black acoustic fleece	approx. 300 x 300 mm
	84010200	Access panel, aluminium, 8/18R, black acoustic fleece	approx. 400 x 400 mm
	84010300	Access panel, aluminium, 8/18R, black acoustic fleece	approx. 500 x 500 mm
	84010400	Access panel, aluminium, 8/18R, black acoustic fleece	approx. 600 x 600 mm
	84010500	Access panel, aluminium, 8/18R, black acoustic fleece	approx. 400 x 600 mm
	84020600	Access panel, aluminium, 12/25R, black acoustic fleece	approx. 200 x 200 mm
	84020100	Access panel, aluminium, 12/25R, black acoustic fleece	approx. 300 x 300 mm
	84020200	Access panel, aluminium, 12/25R, black acoustic fleece	approx. 400 x 400 mm
	84020300	Access panel, aluminium, 12/25R, black acoustic fleece	approx. 500 x 500 mm
	84020400	Access panel, aluminium, 12/25R, black acoustic fleece	approx. 600 x 600 mm
	84020500	Access panel, aluminium, 12/25R, black acoustic fleece	approx. 400 x 600 mm
	84030600	Access panel, aluminium, 8/12/50R, black acoustic fleece	approx. 200 x 200 mm
	84030100	Access panel, aluminium, 8/12/50R, black acoustic fleece	approx. 300 x 300 mm
	84030200	Access panel, aluminium, 8/12/50R, black acoustic fleece	approx. 400 x 400 mm
	84030300	Access panel, aluminium, 8/12/50R, black acoustic fleece	approx. 500 x 500 mm
	84030400	Access panel, aluminium, 8/12/50R, black acoustic fleece	approx. 600 x 600 mm
	84030500	Access panel, aluminium, 8/12/50R, black acoustic fleece	approx. 400 x 600 mm
	84040600	Access panel, aluminium, 8/18Q, black acoustic fleece	approx. 200 x 200 mm
	84040100	Access panel, aluminium, 8/18Q, black acoustic fleece	approx. 300 x 300 mm
	84040200	Access panel, aluminium, 8/18Q, black acoustic fleece	approx. 400 x 400 mm
	84040300	Access panel, aluminium, 8/18Q, black acoustic fleece	approx. 500 x 500 mm
	84040400	Access panel, aluminium, 8/18Q, black acoustic fleece	approx. 600 x 600 mm
	84040500	Access panel, aluminium, 8/18Q, black acoustic fleece	approx. 400 x 600 mm
	84050600	Access panel, aluminium, 12/25Q, black acoustic fleece	approx. 200 x 200 mm
	84050100	Access panel, aluminium, 12/25Q, black acoustic fleece	approx. 300 x 300 mm
	84050200	Access panel, aluminium, 12/25Q, black acoustic fleece	approx. 400 x 400 mm
	84050300	Access panel, aluminium, 12/25Q, black acoustic fleece	approx. 500 x 500 mm
	84050400	Access panel, aluminium, 12/25Q, black acoustic fleece	approx. 600 x 600 mm
	84050500	Access panel, aluminium, 12/25Q, black acoustic fleece	approx. 400 x 600 mm
	85000600	Access panel, aluminium, smooth plaster insert	approx. 200 x 200 mm
	85000100	Access panel, aluminium, smooth plaster insert	approx. 300 x 300 mm
	85000200	Access panel, aluminium, smooth plaster insert	approx. 400 x 400 mm
	85000300	Access panel, aluminium, smooth plaster insert	approx. 500 x 500 mm
	85000400	Access panel, aluminium, smooth plaster insert	approx. 600 x 600 mm
	85000500	Access panel, aluminium, smooth plaster insert	approx. 400 x 600 mm

Product Range

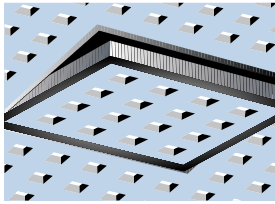

Vogl access panels are the perfect technical solution for quickly adding accessible openings into perforated ceiling areas. The perforated panel insert precisely factory-fitted into the opening frame is lined with white acoustic fleece for high acoustic performance. The specified standard articles are designed for a panel thickness of 12.5 mm.

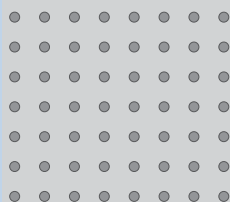
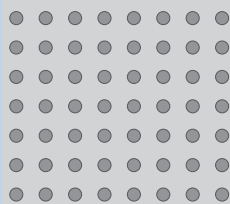
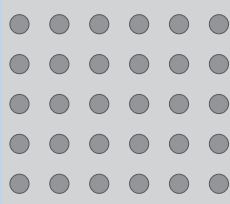
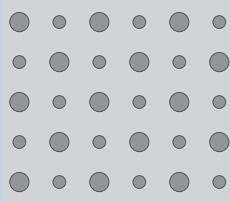
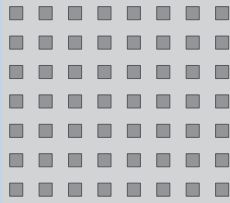
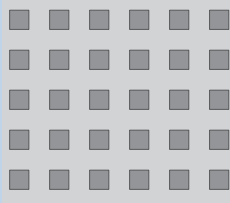
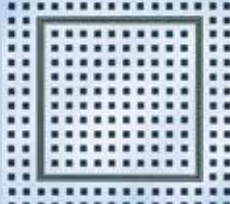



Illustration	Item number	Description	Access opening dimensions
	84100600	Access panel, aluminium, 6/18R, white acoustic fleece	approx. 200 x 200 mm
	84100100	Access panel, aluminium, 6/18R, white acoustic fleece	approx. 300 x 300 mm
	84100200	Access panel, aluminium, 6/18R, white acoustic fleece	approx. 400 x 400 mm
	84100300	Access panel, aluminium, 6/18R, white acoustic fleece	approx. 500 x 500 mm
	84100400	Access panel, aluminium, 6/18R, white acoustic fleece	approx. 600 x 600 mm
	84100500	Access panel, aluminium, 6/18R, white acoustic fleece	approx. 400 x 600 mm
	84110600	Access panel, aluminium, 8/18R, white acoustic fleece	approx. 200 x 200 mm
	84110100	Access panel, aluminium, 8/18R, white acoustic fleece	approx. 300 x 300 mm
	84110200	Access panel, aluminium, 8/18R, white acoustic fleece	approx. 400 x 400 mm
	84110300	Access panel, aluminium, 8/18R, white acoustic fleece	approx. 500 x 500 mm
	84110400	Access panel, aluminium, 8/18R, white acoustic fleece	approx. 600 x 600 mm
	84110500	Access panel, aluminium, 8/18R, white acoustic fleece	approx. 400 x 600 mm
	84120600	Access panel, aluminium, 12/25R, white acoustic fleece	approx. 200 x 200 mm
	84120100	Access panel, aluminium, 12/25R, white acoustic fleece	approx. 300 x 300 mm
	84120200	Access panel, aluminium, 12/25R, white acoustic fleece	approx. 400 x 400 mm
	84120300	Access panel, aluminium, 12/25R, white acoustic fleece	approx. 500 x 500 mm
	84120400	Access panel, aluminium, 12/25R, white acoustic fleece	approx. 600 x 600 mm
	84120500	Access panel, aluminium, 12/25R, white acoustic fleece	approx. 400 x 600 mm
	84130600	Access panel, aluminium, 8/12/50R, white acoustic fleece	approx. 200 x 200 mm
	84130100	Access panel, aluminium, 8/12/50R, white acoustic fleece	approx. 300 x 300 mm
	84130200	Access panel, aluminium, 8/12/50R, white acoustic fleece	approx. 400 x 400 mm
	84130300	Access panel, aluminium, 8/12/50R, white acoustic fleece	approx. 500 x 500 mm
	84130400	Access panel, aluminium, 8/12/50R, white acoustic fleece	approx. 600 x 600 mm
	84130500	Access panel, aluminium, 8/12/50R, white acoustic fleece	approx. 400 x 600 mm
	84140600	Access panel, aluminium, 8/18Q, white acoustic fleece	approx. 200 x 200 mm
	84140100	Access panel, aluminium, 8/18Q, white acoustic fleece	approx. 300 x 300 mm
	84140200	Access panel, aluminium, 8/18Q, white acoustic fleece	approx. 400 x 400 mm
	84140300	Access panel, aluminium, 8/18Q, white acoustic fleece	approx. 500 x 500 mm
	84140400	Access panel, aluminium, 8/18Q, white acoustic fleece	approx. 600 x 600 mm
	84140500	Access panel, aluminium, 8/18Q, white acoustic fleece	approx. 400 x 600 mm
	84150600	Access panel, aluminium, 12/25Q, white acoustic fleece	approx. 200 x 200 mm
	84150100	Access panel, aluminium, 12/25Q, white acoustic fleece	approx. 300 x 300 mm
	84150200	Access panel, aluminium, 12/25Q, white acoustic fleece	approx. 400 x 400 mm
	84150300	Access panel, aluminium, 12/25Q, white acoustic fleece	approx. 500 x 500 mm
	84150400	Access panel, aluminium, 12/25Q, white acoustic fleece	approx. 600 x 600 mm
	84150500	Access panel, aluminium, 12/25Q, white acoustic fleece	approx. 400 x 600 mm
		<p>Access panels aluminium</p> <p>Custom models: custom dimensions, single and double flap design, integrated cable duct</p> <p>When ordering, please specify size of access opening and desired perforation pattern</p>	

Illustration	Item number	Description	Model	PU
	86201100	VoglModu® Quad A/P 1000 x 1000 mm DI	Overall height: 170 mm Housing colour: white, similar to RAL 9010	1 Piece/PU
	86201200	VoglModu® Quad A/P 1000 x 1000 mm DALI		1 Piece/PU
	86202100	VoglModu® Quad A/P 1300 x 1300 mm DI		1 Piece/PU
	86202200	VoglModu® Quad A/P 1300 x 1300 mm DALI		1 Piece/PU
	86203100	VoglModu® Quad A/P 1600 x 1600 mm DI		1 Piece/PU
	86203200	VoglModu® Quad A/P 1600 x 1600 mm DALI		1 Piece/PU
	86299100	VoglModu® Quad A/P wire suspension 1000-1300	1.5 m/suspension	4 pcs./PU
	86299200	VoglModu® Quad A/P wire suspension 160		4 pcs./PU
	86101100	VoglModu® Round A/P 950 mm DI	Overall height: 170 mm Housing colour: white, similar to RAL 9010	1 Piece/PU
	86101200	VoglModu® Round A/P 950 mm DALI		1 Piece/PU
	86102100	VoglModu® Round A/P 1250 mm DI		1 Piece/PU
	86102200	VoglModu® Round A/P 1250 mm DALI		1 Piece/PU
	86103100	VoglModu® Round A/P 1550 mm DI		1 Piece/PU
	86103200	VoglModu® Round A/P 1550 mm DALI		1 Piece/PU
	86199100	VoglModu® Round A/P wire suspension 950-1250	1.5 m/suspension	4 pcs./PU
	86199200	VoglModu® Round A/P wire suspension 1550		4 pcs./PU
	86111100	VoglModu® Round E 950 mm DI	Overall height: 200 mm	1 pcs./PU
	86111200	VoglModu® Round E 950 mm DALI		1 pcs./PU
	86112100	VoglModu® Round E 1250 mm DI		1 pcs./PU
	86112200	VoglModu® Round E 1250 mm DALI		1 pcs./PU
	86113100	VoglModu® Round E 1550 mm DI		1 pcs./PU
	86113200	VoglModu® Round E 1550 mm DALI		1 pcs./PU

DI = Standard model, dimmable 1-10V, for electronic ballasts

DALI = short for "Digital Addressable Lighting Interface" – the standardised digital interface for electronic ballasts. DALI intelligent light management offers many advantages.

All light modules come with light strips and diffuser foil, but without the appropriate illuminants.
 For more information on installation and electric requirements, please refer to our technical documentation.





Our partner in the range of illuminated and stretch ceilings

You are planning, calculating or carrying out a project that includes both perforated plasterboard ceilings (or ceiling tiles, moulded components, plaster ceilings, etc.) and illuminated ceilings?

Contact us and we will be glad to coordinate the interfaces with our partner Rentex for you. This way you will have only one contact partner for manifold, perfectly designed ceiling surfaces.

Since 1987, Rentex Wand- und Deckensysteme GmbH has been supporting architects, planners and project owners with system solutions for illuminated ceilings and walls from the design stage to the functional, inspected and approved luminous surface. Whether glass, foil or technical lighting fabric, Rentex has a broad range of profile systems for all diffusers to satisfy every design and structural requirement.

The spectrum of lighting and control technology ranges from manual dimmability to computer-aided daylight simulation and dynamic RGB colour mixing. The highlights are made-to-measure ceiling structures of foil, glass or fabric, unusual 3D shapes or complex systems with integrated ventilation, cooling and sound protection.

www.rentex-systeme.de

Vogl Stretch Ceilings offer almost unlimited freedom of design with:

- Exciting surfaces and three-dimensional shapes
- Contrasts between colours and degrees of gloss
- Accentuated interaction of light and illumination
- Printed foils for more Corporate Design
- Ideal combination possibilities in form, colour and performance with Vogl acoustic design ceilings

For several years, we have worked hand-in-hand with our partner Rentex in the field of illuminated and stretch ceilings.

This cooperation offers significant advantages for you:

- One contact partner who coordinates all interfaces for you
- Numerous design options by combining acoustic design ceiling, acoustic plaster ceiling, customised moulded components and illuminated/stretch ceiling
- You get the complete technical documentation and drawings from us
- We find qualified specialist contractors for you



Illustration	Item number	Description	Dimensions	PU PU/pallet
<p>Illustration shows Voglfriestape-Set® 50 mm</p>	90005324	Voglfriestape-Set® 20 mm Tape width 20 mm	2 rolls of tape 20 mm = 200 linear metres (lm)	1 PU = 1 set 72 PU/pallet
	90005325	Voglfriestape-Set® 50 mm Tape width 50 mm	3 rolls of tape 50 mm = 150 lm	1 PU = 1 set 72 PU/pallet
	90005326	Voglfriestape-Set® 75 mm Tape width 75 mm	2 rolls of tape 75 mm = 100 lm	1 PU = 1 set 72 PU/pallet
	90005327	Voglfriestape-Set® 100 mm Tape width 100 mm	1 roll of tape 100 mm = 50 lm	1 PU = 1 set 72 PU/pallet
	90005328	Voglfriestape-Set® 150 mm Tape width 150 mm	1 roll of tape 150 mm = 50 lm	1 PU = 1 set 72 PU/pallet
		Voglfriestape-Set® contains all tools and materials necessary for creating individual frieze areas		
	90053000	Connection pliers Sturdy connection pliers for quick and secure fixing of framework elements of up to 2 x 1 mm sheet thickness		1 PU = 1 piece
	90022000	Chamfer plane Ergonomic special chamfer plane made of a handy cast zinc housing and with exchangeable blades for quick chamfering of plasterboards 22° or 45°		1 PU = 1 piece
	90022095	Replacement blades for chamfer plane		1 PU = 100 piece
	90231000	Hand sander Body made of impact-resistant plastic, foam rubber sanding pad fastens with wing screws	240 x 80 mm	1 PU = 1 piece
	90234000	Sanding paper 100 grit	280 x 115 mm	1 PU = 100 sheets
	90233000	Abrasive mesh 100 grit	280 x 100 mm	1 PU = 10 sheets
	90310000	Double layer fleece VAD 32 black Self-adhesive fleece, black	Roll width 32 mm Roll length 200 m	1 PU = 1 roll 60 PU/pallet
	90320000	Double layer fleece VAD 62 black Self-adhesive fleece, black	Roll width 62 mm Roll length 200 m	1 PU = 1 roll 60 PU/pallet
	90311000	Double layer fleece VAD 32 white Self-adhesive fleece, white	Roll width 32 mm Roll length 200 m	1 PU = 1 roll 60 PU/pallet
	90321000	Double layer fleece VAD 62 white Self-adhesive fleece, white	Roll width 62 mm Roll length 200 m	1 PU = 1 roll 60 PU/pallet

Illustration	Item number	Description	Dimensions	PU PU/pallet
	90062000	Drywall saw Quick, safe cutting of plasterboards. Sharp point for easy penetration into the material, ergonomic wooden handle	Blade length = 155 mm	1 PU = 1 piece
	90027000	Round rasp Keyhole saw with plastic handle Diameter 4.8 mm	Blade length = 220 mm	1 PU = 1 piece
	90203000	Bucket trowel With wooden handle, stainless steel blade	Trowel blade = 80 mm	1 PU = 1 piece 12 pcs./box
	90204000	Screw head trowel With wooden handle, stainless steel blade, 2 holes for excess filling over screw heads (diameter 8 mm and 10 mm)	Trowel blade = 80 mm	1 PU = 1 piece
	90201100	Screwdriver handle trowel Wooden handle with integrated screw bit PH2, Stainless steel blade	Trowel blade = 150 mm	1 PU = 1 piece 10 pcs./box
	90010000	Universal mixing paddle Sturdy mixing paddle (hot-dip galvanised) for use with power drills. 9 mm chuck. Splash-free stirring/mixing for thin and thick mixtures, e.g. fillers, acoustic plaster, emulsion paints	Diameter = 90 mm, shaft length = 390 mm	1 PU = 1 piece
	90180000	Joint sealing set, 3-piece Consisting of: tube, plunger, nozzle		1 PU = 1 set 25 sets/pallet
	90180094	Spare parts for joint sealing set tube L = 210 mm		1 PU = 1 piece
	90180095	plunger		1 PU = 1 piece
	90180096	nozzle		1 PU = 1 piece
	90071098	Perforation wheel 6/18R		1 PU = 1 piece
	90072098	Perforation wheel 8/18R		1 PU = 1 piece
	90073098	Perforation wheel 10/23R		1 PU = 1 piece
	90074098	Perforation wheel 12/25R		1 PU = 1 piece
	90075098	Perforation wheel 15/30R		1 PU = 1 piece
	90090000	Handle with knurled screw Attention when ordering: order handle separately		1 PU = 1 piece



Illustration	Item number	Description	Dimensions/contents/ consumption	PU PU/pallet
	90191000 90192000 90193000 90194000 90195000 90196000 90198000	Drilling template 6/18R Drilling template 8/18R Drilling template 10/23R Drilling template 12/25R Drilling template 15/30R Drilling template 8/12/50R Drilling template 12/20/66R Drilling templates made of stainless steel		1 PU = 1 piece 1 PU = 1 piece 1 PU = 1 piece 1 PU = 1 piece 1 PU = 1 piece 1 PU = 1 piece 1 PU = 1 piece
	90171100 90172100 90173100 90174100 90175100 90176100 90178100	Mounting aid 6/18R set Mounting aid 8/18R/Q set Mounting aid 10/23R set Mounting aid 12/25R/Q set Mounting aid 15/30R set Mounting aid 8/12/50R set Mounting aid 12/20/66R set Consisting of: 2 x mounting aid		1 PU = 1 set 1 PU = 1 set 1 PU = 1 set 1 PU = 1 set 1 PU = 1 set 1 PU = 1 set 1 PU = 1 set
	90501300	Vogl Supergrund primer LF 20 I Universal primer, absorbency regulating, free from solvents and softening agents, low-emission, free from active fogging sub- stances	1 canister = 20 litres Consumption: approx. 0.15 l/m ²	1 PU = 1 canister 24 canisters/pallet

Illustration	Item number	Description	Dimensions/contents/ consumption	PU PU/pallet
	90503200	Vogl ceiling paint White Premium 15 I Very well covering indoor emulsion paint, free from solvents and softening agents, low-emission, wet abrasion class 3 as per EN 13300, white, free from active fogging substances, very high whiteness, dull matt.	1 bucket = 15 litres Consumption: approx. 0.3 l/m ² in two working steps	1 PU = 1 bucket 24 buckets/pallet
	90504200	Vogl ceiling paint Colormix Plus 15 I Well covering indoor emulsion paint, free from solvents and softening agents, low-emission, wet abrasion class 3 as per EN 13300, dull matt, free from active fogging substances; please specify colour of choice (RAL etc.) when ordering.	1 bucket = 15 litres Consumption: approx. 0.3 l/m ² in two working steps	1 PU = 1 bucket 24 buckets/pallet
	90605000	VoglToptec® plaster base fleece Special glass fibre fleece as plaster base for coating with acoustic plaster, non-combustible, crack-bridging, damp-proof, dimensionally stable, white colour, designed for gluing onto perforated ceiling panels with special adhesive.	Roll width = 1.145 mm Roll length = 100 m	1 PU = 1 roll 15 rolls/pallet
	90608000	VoglToptec® plaster base fleece, small Special glass fibre fleece as plaster base for coating with acoustic plaster, not combustible A2, crack-bridging, damp-proof, dimensionally stable, white colour. The handy-sized roll of plaster base fleece is especially suited for applying wallpaper in the perimeter/wall connection area as well as for custom solutions.	Roll width = 500 mm Roll length = 100 m	1 PU = 1 roll
	90604000	VoglToptec® special adhesive Ready-to-use, dispersion adhesive, tested for harmful substances, for bonding the plaster base fleece to perforated ceiling panels, free from solvents and softening agents, low-emission, free from active fogging substances, ready-mixed product.	1 bucket = 16 kg Consumption: approx. 0.3 kg/m ²	1 PU = 1 bucket 24 buckets/pallet
	90602000	VoglToptec® Akustik Nano SF Decorative, open-pored, machine-applied acoustic plaster, very fine texture, grain size up to 0.5 mm, dull matt, high degree of whiteness, ready-mixed product.	1 bucket = 18 kg Consumption: 2.7 - 3.0 kg/m ²	1 PU = 1 bucket 24 buckets/pallet
	90602100	VoglToptec® Akustik Color Nano SF Decorative, open-pored machine-applied acoustic plaster, very fine texture, grain size up to 0.5 mm, ready-mixed product; please specify colour of choice (RAL etc.) when ordering.	1 bucket = 18 kg Consumption: 3.0 - 3.5 kg/m ² *	1 PU = 1 bucket 24 buckets/pallet
	90607000	VoglToptec® wallpaper smoother Top-quality wallpaper smoother made of plastic suitable for wallpapering the plaster base fleece in the VoglToptec® system.		1 PU = 1 piece

*Note: Dark or special colour shades may lead to increased consumption. Actual quantities depend on the respective project.

Illustration	Item number	Description	Dimensions	Unit
	Z02	Europallets, charged Europool pallet, wood UIC standard 435/2	1200 x 800 x 144 mm	1 piece
	Z03	Europallets, exchanged Europool pallet, wood UIC standard 435/2	1200 x 800 x 144 mm	1 piece
	Z04	Panel pallet, charged Wooden panel pallet for perforated ceiling panels or custom moulded components	2000 x 1250 x 115 mm 2500 x 1250 x 115 mm 3000 x 1250 x 115 mm	1 piece 1 piece 1 piece
	Z06	Additional charges on time and material basis		1 piece
	Z19	Surcharge – for sale of smaller pallet units		1 piece
	Z20	Special palletising – acoustic design panels		1 piece
	Z08	Plastic foil hood for Europallets PE foil hood		1 piece
	Z09	Plastic foil hood for Europallets PE foil hood		1 piece
	Z10	Thermal protection hood for Europallets Frost-proof pallet packaging		1 piece
	Z05	Proportional shipping costs Calculation of proportional shipping costs; for net values less than the limit for delivery "free domicile"		1 piece
	Z15	Unloading costs at ground level with forklift Truck-mounted forklift; calculation base: per metric tonne of load, 15 minutes unloading by forklift included		1 piece
	Z17	Unloading costs with crane 18 - 27 m Unloading with truck-mounted crane; on request		1 piece
	Z18	Unloading costs with crane 27 m Unloading with truck-mounted crane; on request		1 piece
	Z22	Parcel service charges standard 48 h service*	* Specified door-to-door times only valid within Germany	1 piece
Z23	Parcel service charges express 24 h service*	1 piece		
Z24	Parcel service charges overnight – 10:30 a.m. fix*	1 piece		
Z25	Parcel service charges overnight – 09:00 a.m. fix*	1 piece		
		Interseroh Recycling Certificate no. 32196 Our packaging materials are documented with Interseroh and will be collected and recycled by Interseroh partners on request. More information is available upon request.		

VoglFuge®

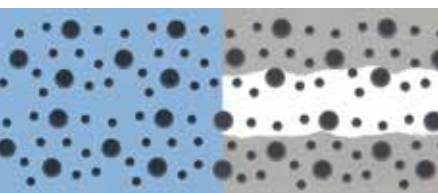

Ceilings

without Filler

Create perfect acoustic designer ceilings with the VoglFuge® system

with air purification
effect as standard

Ceilings without filler

Design acoustic ceilings meet the highest demands on performance and aesthetics for interior design. Particularly in highly frequented areas, such ceiling systems serve as sound absorbers, cooling element and eye catcher at the same time. For this reason, high precision in installation is particularly needed here. Unlike conventional ceiling solutions, errors in the installation are immediately visible in the finished product and seriously affect the final appearance.

This is where the VoglFuge® system comes into play, allowing acoustic design ceilings to be implemented quickly, economically and with the most reliability during installation for guaranteed results.



Benefits of the VoglFuge® system:

The unique joint technology offers maximum reliability for installation and finishes:

- Quick mounting of panels – edge to edge
- No more complex panel alignment
- Ultra-quick joint finishing with our unique VoglFuge® Strip
- Significant time saving due to quick installation and drying times
- Maximum crack resistance
- Less dust and moisture
- Always complete with the VoglFuge® System Kit including perforated panel screws SN 3.5 x 30 mm



The VoglFuge® System Kit includes the required material, tools and a detailed assembly instruction to ensure the top quality of workmanship and result.

The right tools at the right time in exactly the right place.

Our VoglFuge® System Kit is only available in combination with Vogl acoustic design panels. It cannot be purchased separately.

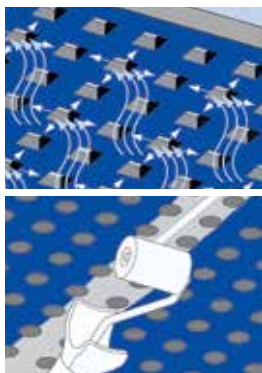

The VoglFuge® System of Vogl acoustic design ceilings is represented by perforated ceiling panels with high acoustic performance and air purification effect (adsorption).

Black or white acoustic fleece backing (other fleece colours on request), all sides sharp-edged with undercut for installation using the quickest and most secure edge to edge laying principle.

Other available options: Vogl acoustic design panels with non-perforated edges, block perforation, applications, manufacture in accordance with customer designs and ceiling plans.

Delivery including VoglFuge® System Kit (incl. perforated panel screws SN 3.5x30).

Standards: EN 14190 "Gypsum plasterboard products from reprocessing"
Material class: A2-s1, d0 (non-flammable) according to EN 13501
Long edge: SK (sharp-edged)
Short edge: SK (sharp-edged)



Illustration	Item number	Description	Details	m ² /pallet Panels/pallet
	7061101110	Acoustic design panel VF 6/18R Acoustic fleece, black	1188 x 1998 x 12.5 mm	59.3 m ²
	7061101120	Acoustic design panel VF 6/18R Acoustic fleece, white	Perforated area: 8.7 % Mass: 9.1 kg/m ²	25 pcs.
	7061102110	Acoustic design panel VF 8/18R Acoustic fleece, black	1188 x 1998 x 12.5 mm	59.3 m ²
	7061102120	Acoustic design panel VF 8/18R Acoustic fleece, white	Perforated area: 15.5 % Mass: 8.5 kg/m ²	25 pcs.
	7061103110	Acoustic design panel VF 10/23R Acoustic fleece, black	1196 x 2001 x 12.5 mm	59.8 m ²
	7061103120	Acoustic design panel VF 10/23R Acoustic fleece, white	Perforated area: 14.8 % Mass: 8.5 kg/m ²	25 pcs.
	7061104110	Acoustic design panel VF 12/25R Acoustic fleece, black	1200 x 2000 x 12.5 mm	60.0 m ²
	7061104120	Acoustic design panel VF 12/25R Acoustic fleece, white	Perforated area: 18.1 % Mass: 8.2 kg/m ²	25 pcs.
	7061105110	Acoustic design panel VF 15/30R Acoustic fleece, black	1200 x 1980 x 12.5 mm	59.4 m ²
	7061105120	Acoustic design panel VF 15/30R Acoustic fleece, white	Perforated area: 19.6 % Mass: 8.0 kg/m ²	25 pcs.
	7061106110	Acoustic design panel VF 8/12/50R Acoustic fleece, black	1200 x 2000 x 12.5 mm	60.0 m ²
	7061106120	Acoustic design panel VF 8/12/50R Acoustic fleece, white	Perforated area: 13.1 % Mass: 8.7 kg/m ²	25 pcs.
	7061107110	Acoustic design panel VF 12/20/66R Acoustic fleece, black	1188 x 1980 x 12.5 mm	58.8 m ²
	7061107120	Acoustic design panel VF 12/20/66R Acoustic fleece, white	Perforated area: 19.6 % Mass: 8.0 kg/m ²	25 pcs.
	7061108110	Acoustic design panel VF 8/18Q Acoustic fleece, black	1188 x 1998 x 12.5 mm	59.3 m ²
	7061108120	Acoustic design panel VF 8/18Q Acoustic fleece, white	Perforated area: 19.8 % Mass: 8.0 kg/m ²	25 pcs.
	7061109110	Acoustic design panel VF 12/25Q Acoustic fleece, black	1200 x 2000 x 12.5 mm	60.0 m ²
	7061109120	Acoustic design panel VF 12/25Q Acoustic fleece, white	Perforated area: 23.0 % Mass: 7.7 kg/m ²	25 pcs.
	7061110110	Acoustic design panel VF 8/15/20R Acoustic fleece, black	1200 x 2000 x 12.5 mm	60.0 m ² *
	7061110120	Acoustic design panel VF 8/15/20R Acoustic fleece, white	Perforated area: 9.5 % Mass: 9.1 kg/m ²	25 pcs.
	7061111110	Acoustic design panel VF 12/20/35R Acoustic fleece, black	1200 x 2000 x 12.5 mm	60.0 m ² *
	7061111120	Acoustic design panel VF 12/20/35R Acoustic fleece, white	Perforated area: 11.0 % Mass: 8.9 kg/m ²	25 pcs.
	7061112110	Acoustic design panel VF 5/82/15.4SL Acoustic fleece, black	1186 x 1984 x 12.5 mm	58.8 m ²
	7061112120	Acoustic design panel VF 5/82/15.4SL Acoustic fleece, white	Perforated area: 21.5 % Mass: 7.9 kg/m ²	25 pcs.

*Note: Despite being perforated irregularly, random perforation panels still yield a certain linear layout as the abutting panel edges must be non-perforated in any case. This is unavoidable and independent of the workmanship of the specialist contractor.

Block slot										
Design	Slot	Slots per "block"		Rim* (unslotted)		Slotted area (panel)	Panel dimensions (standard size)		Secondary profile (centre distance)	Edges
		Short	Long	Short (mm)	Long (mm)	%	Width mm	Length mm	mm	
4F	5/82/15.4SL	69	4	73.9	73.3	15.7	1200	2400	300	SK
8F	5/82/15.4SL	30	4	73.9	73.3	13.7	1200	2400	300	SK
8/16F	5/82/15.4SL	4 x 6	4	73.9	73.3	10.9	1200	2400	300	SK

*Edge dimensions refer to visible rim

Block perforation										
Design	Perforation	Holes per "block"		Rim* (unperforated)		Perforated area (panel)	Panel dimensions (standard size)		Secondary profile (centre distance)	Edges
		Short	Long	Short (mm)	Long (mm)	%	Width mm	Length mm	mm	
4F	8/18R	64	30	41	41	12.9	1224	2448	312.5	SK
	12/25R	45	21	44	44	14.9	1200	2400	300	SK
	12/25Q	45	21	44	44	18.9	1200	2400	300	SK
8F	8/18R	30	30	41	41	12.1	1224	2448	312.5	SK
	12/25R	21	21	44	44	13.9	1200	2400	300	SK
	12/25Q	21	21	44	44	17.7	1200	2400	300	SK
32F	8/18R	13	13	41	41	9.1	1224	2448	312.5	SK
	12/25R	9	9	44	44	10.2	1200	2400	300	SK
	12/25Q	9	9	44	44	13.0	1200	2400	300	SK

*Edge dimensions refer to visible rim

Diagrams represent visible side

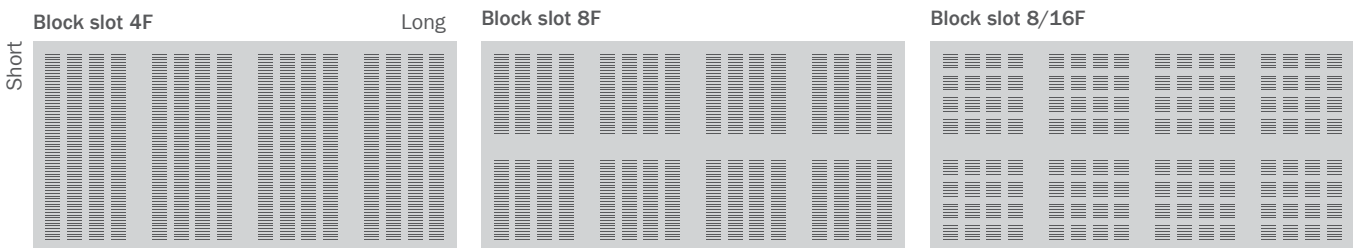

Slot only possible in longitudinal direction of the ceiling panels.

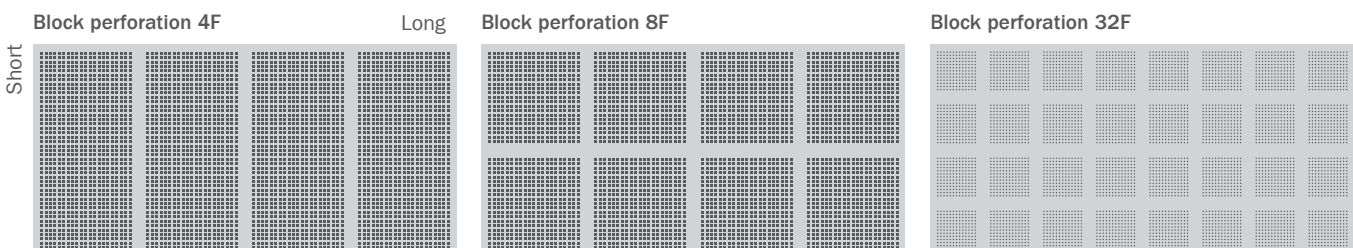

Example: 12/25Q

Example: 12/25Q

Example: 8/18R

VoglFuge® panels with non-perforated edges

1 rims non-perforated

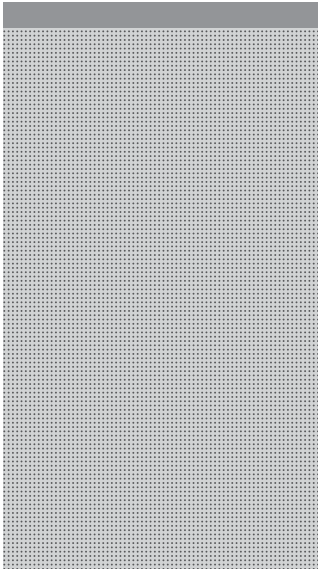

2 rims non-perforated

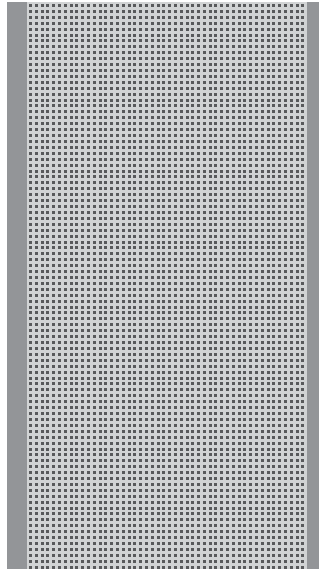

3 rims non-perforated

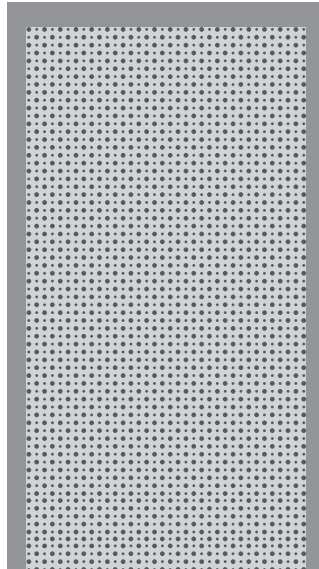

4 rims non-perforated

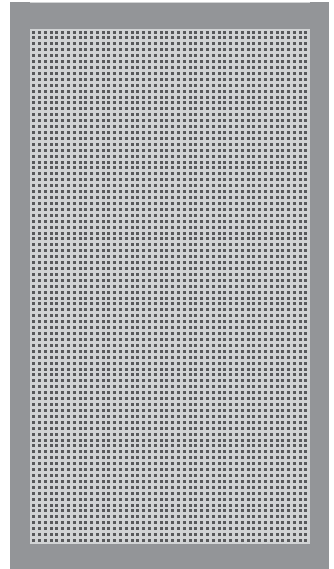

VoglFuge® panels with custom components

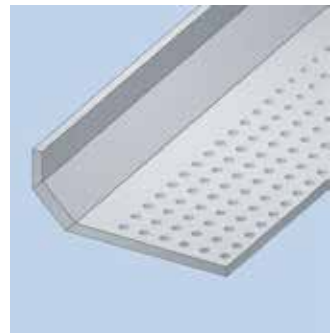
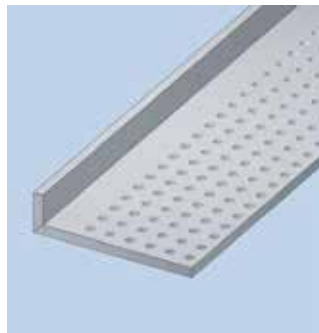
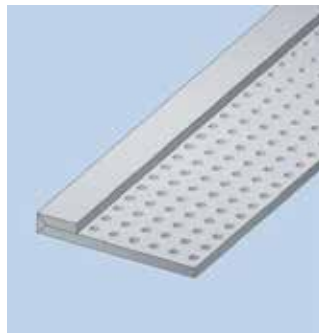
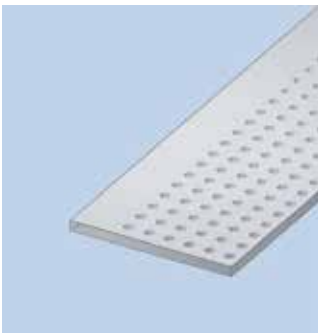

VoglFuge® panels according to layout plan

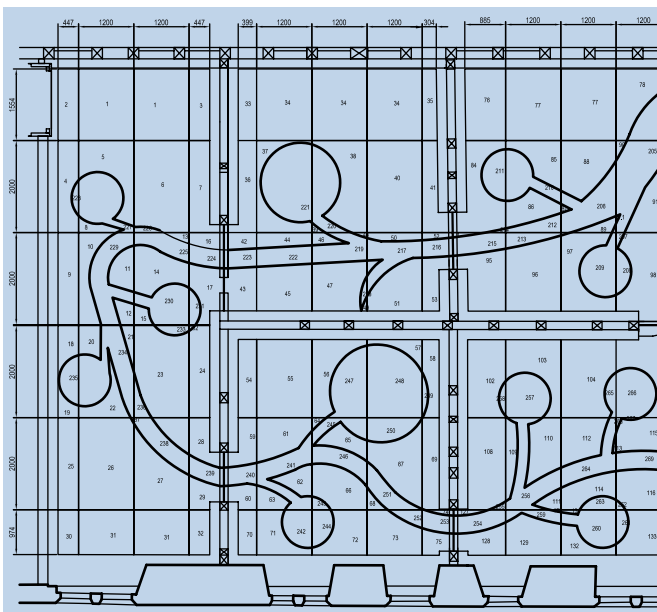

You want a ceiling that features not only high acoustic performance, but also outstanding appearance?

We are always pleased to help; our experts can adapt our acoustic design panels exactly to your desired ceiling surface. When manufacturing ceiling systems to plan, we supply the custom-made and perfectly fitted acoustic design panels as well as a layout plan for use on the job site, thus ensuring reliable results for the installation. And of course, our moulded components, stretch ceilings and ceiling components can be perfectly integrated into your planned ceiling surface.



The primary profiles are hung from the structural soffit with suspended brackets using fixing materials approved by the relevant building authorities.

The centre distance and number of suspended brackets, as well as the fixing material, are subject to site requirements and EN 13964/ DIN 18181. The CG 60/27 secondary profiles are attached to the primary profiles CD 60/27 using cross connectors.

CD 60/27 profiles are extended using straight connectors. For primary grid profiles, always ensure that the joint is close to a suspended bracket (max. 100 mm). Joints should be staggered.

The plasterboards should be installed in accordance with EN 13964/ DIN 18181 and the manufacturer's guidelines.

Additional items such as lighting, ventilation, sprinkler systems etc. must be individually suspended.

Any changes in the framework resulting from additional ceiling mounted items must be considered.

Block perforations and block slots require different centre distances of the secondary profiles which are shown in our tables on page 74.

Framework VoglFuge®								
Technical data	Unit	Perforated panel ceiling						
Panel thickness	mm	12.5						
Distributed load	kN/m ²	≤ 0.15					≤ 0.30	
Centre distance of suspended bracket A	mm	1150	1050	1000	950	900	900	750
Centre distance of primary profiles X	mm	600	800	900	1000	1100	600	1000
Centre distance of secondary profiles Y	mm	see table below						

Article	Unit	Centre distance of secondary profiles Y
Acoustic design panel 6/18; 8/18; 8/18Q; 10/23; 12/25; 12/25Q; 8/12/50; 8/15/20; 12/20/35	mm	333
Acoustic design panel 15/30 12/20/66	mm	330
Acoustic slot panel 5/82/15.4	mm	250

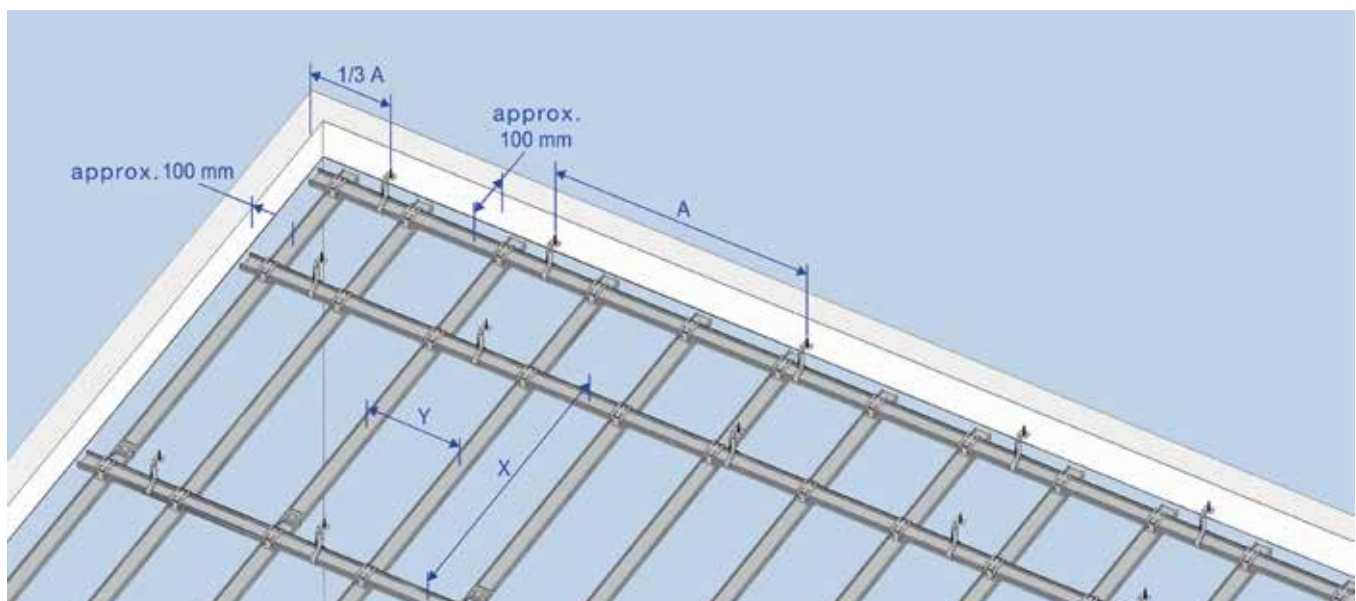

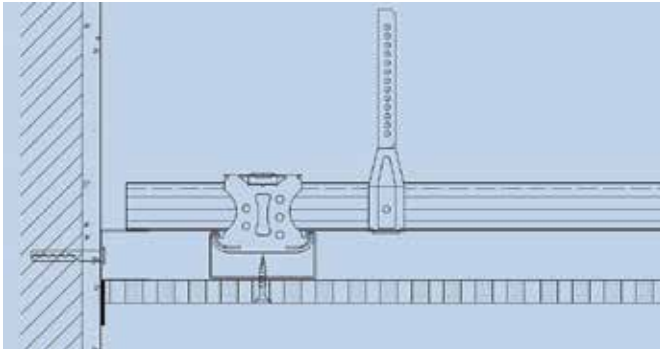

Wall connection with filled joint:

For filled wall connections, a double layer fleece strip is used to separate the acoustic ceiling from the wall.

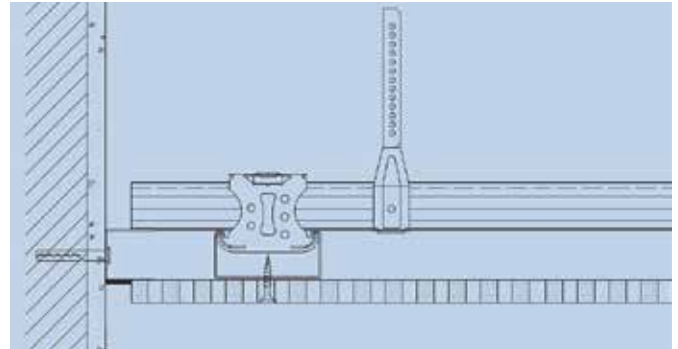

Wall connection – shadow gap:

For wall connections with a shadow gap the panel is only installed up to the UD profile as this may be covered with a strip of adhesive double layer fleece in order to colour the shadow gap.

Please contact us if you require additional technical details on possible wall connections.

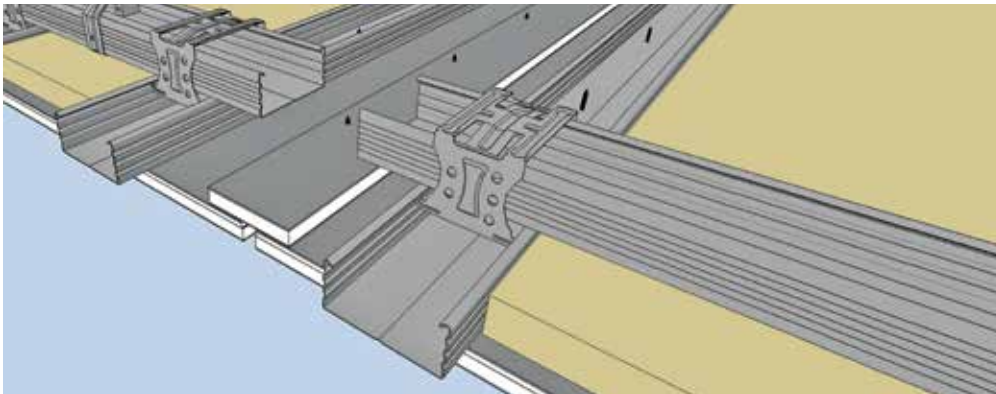

Expansion joints:

To reduce the risk of cracking in the ceiling, expansion joints should be installed every 10 linear metres / 100 m² of ceiling area.

The framework must be completely severed (see illustration) and the panel strips above the joint must only be fixed to one side.

Tip: The panel strip may be covered with adhesive double layer fleece on the visible side if colouring the expansion joint in either black or white is desired.

Material required per m² based on a ceiling of 100 m² (10 m x 10 m, without loss or waste)

Metal framework, suspended bracket centre distance 1000 mm, primary profile spacing 900 mm, secondary profile spacing 333 mm

Article no.	Article description	Unit	Quantity
Fixation			
Standard	Safety nail, DN 6 x 35	pcs.	1,3
Suspended bracket			
2016X000	Direct suspended bracket 50/120/200 and	pcs.	1,3
50809000	Tapping screw LN 3.5 x 9.5	pcs.	2,6
or			
20128 / 20151	Vernier hanger/vernier bottom part and	pcs.	1,3
25501000	Vernier safety bolt and	pcs.	1,3
25XXX000	Vernier top part, 200 - 2000 mm, custom lengths on request	pcs.	1,3
Profiles and connectors			
100XX000	CD profile 60/27/0.6 rK, L=XXX mm	m	4,1
10230000	UD profile 28/27/0.6, 3000 mm	pcs.	0,4
20159000	Connector, lengthwise, CD 60/27	pcs.	0,8
20135000	Cross connector, CD 60/27	pcs.	3,3
52130000	Perforated panel screw SN 3.5 x 30	pcs.	22

Check ceiling framework for rigidity and evenness (using a straightedge).

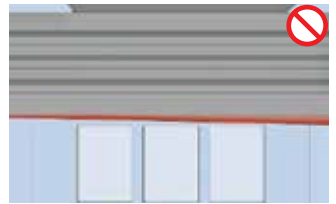
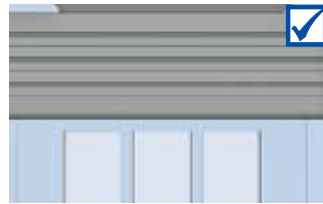

Then check ceiling grid CD sections for centre distances and adjust as necessary. Always mount straight connectors in a staggered manner (see figure) Measure centre distances accurately!

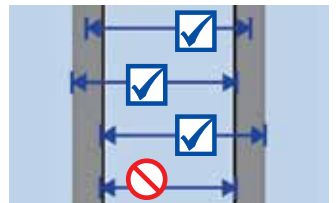
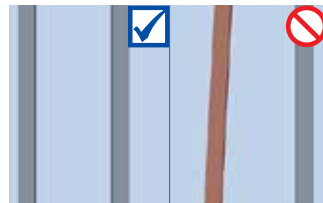
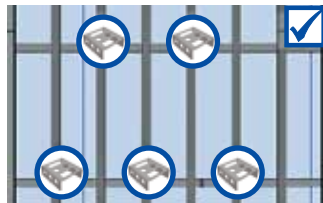

As viewed from the entrance to the area, choose the panel arrangement with short edge parallel to the windows (main direction of light).



Locate centre of room to position first ceiling panel, also taking into account resulting ceiling perimeter to wall connections.



We recommend the following assembly accessories:

perforated panel screws, including screw bit

Correct handling of ceiling panels:

- Always take into account the building's load carrying capacity when storing ceiling panels
- Do not store ceiling panels upright, but always flat on panel pallets
- Always carry ceiling panels with short edges upright
- Protect ceiling panels from moisture; relative humidity should be 40 - 80 %
- Avoid major temperature fluctuations
- Do not expose stored ceiling panels to direct sunlight

Get panel to correct position on grid using a panel lifter if working alone, or otherwise use another worker's help.



Perforation pattern	Centre distance
Straight round perforation 6/18, 8/18, 10/23, 12/25 Offset round perforation 8/12/50, Straight square perforation 8/18, 12/25 Random perforation 8/15/20, 12/20/35	333 mm
Straight round perforation 15/30 Offset round perforation 12/20/66	330 mm
Slot perforation 5/82/15.4	250 mm

Screw panel into place paying attention to right angles, whereas the countersunk heads have to be screwed below the panel's face except for 0.5 mm.

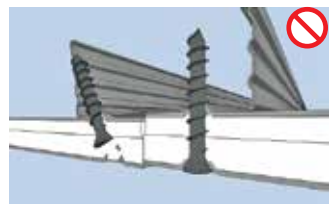
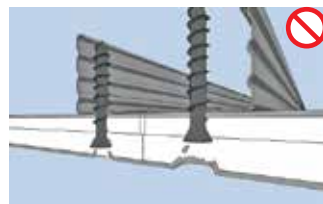
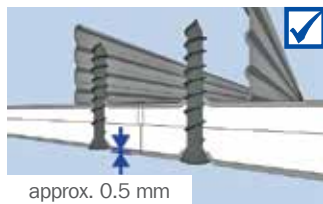

approx. 0.5 mm

Screws should be spaced maximum 170 mm from fixing point to fixing point. The distance between the screw and the panel edge shall not to exceed 26 mm. Avoid damaging acoustic design panels by countersunk heads.

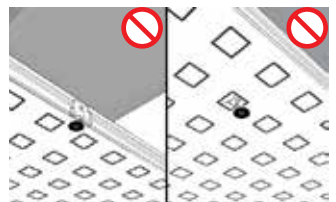
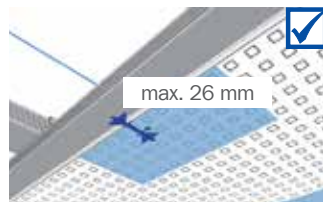

max. 170 mm

max. 26 mm

First, screw the ceiling panel to the framework in the centre of the panel, then lower the panel lifter and fix a screw in the centre of each short edge before finally screwing down long edges.

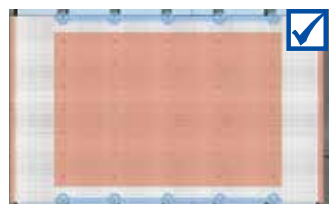
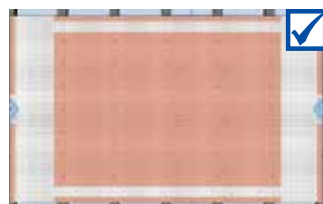

Take note of panel labelling (stamp) and mount in the direction of reading (all stamps should point in the same direction).



Use a CD profile or straight edge as an end stop. To bring into position, slide the next panel to the first panel alongside the CD profile/straight edge and fix.



General site conditions/Manufacturer's instructions:

- Take into account the building structure's expansion joints
- Plan to include expansion joints after approx. every 10 m or approx. 100 m²
- Cardboard layer must not be penetrated by screws, but merely displaced downwards
- Working temperature should be at least +10 °C and job site temperature not below +5 °C
- Place any damping (mineral wool layer) directly onto the ceiling panels
- Carry out any additional work on ceiling (access openings, lighting recesses) immediately after installing ceiling panels and always before finishing joints

Fix screws in panel joint area using alternating pairs across panels ("zig-zag" principle), starting left or right next to the locating screw which has already been fixed. This will create flush joint areas.

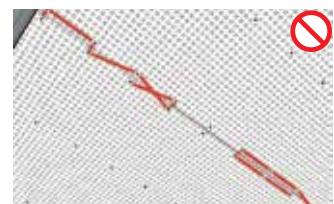
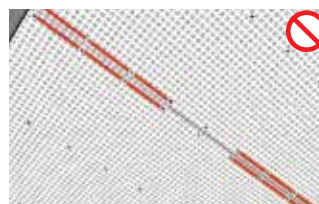

Install ceiling panels first lengthways, then crossways, resulting in a cross arrangement on the ceiling. Cover remaining areas in same manner, working from centre of room outwards.

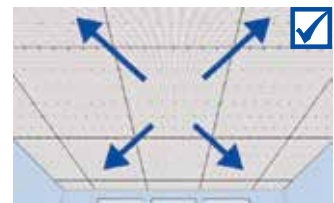

Lay the remaining ceiling panels edge to edge, always checking that the joints are level. Install panels exclusively in the "cross joint" system.

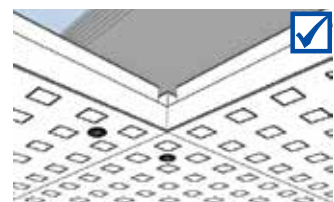
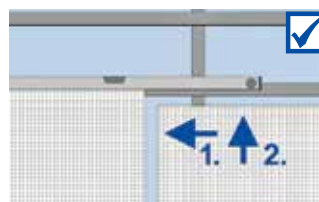

After all the panels have been installed, recheck that all joints are level and adjust, if necessary, using a screwdriver. Then check with a straight edge.

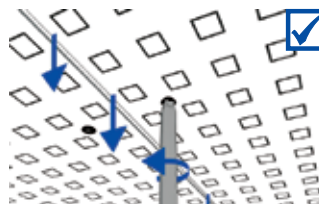

Place any damping layer directly onto back of ceiling panels.

Never screw into UD28 profile when mounting panels at ceiling perimeter.

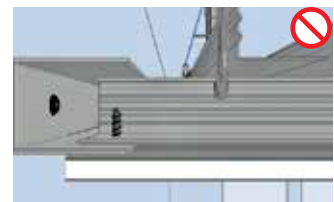
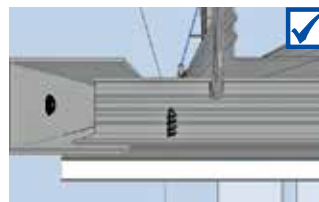
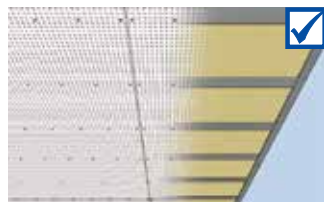

Provide for an expansion joint of 5 to 10 mm every 10 linear metres/100 m².

The additional board strips above the joint must only be fixed on one side.

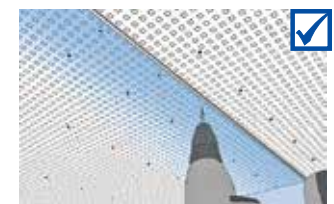

Important! All work that could result in damage to the ceiling surface must be completed before commencing jointing.

Check ceiling! Level out any height discrepancies in the panel joint areas using a screwdriver, if necessary repair any chips or damage to the plasterboard. Then spot fill the screw heads in the joint areas.

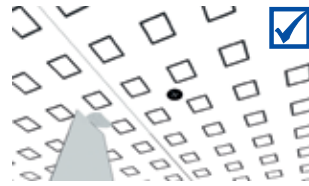

Voglfuge® System Kit contents:

Vogl liquid glue, Vogl strip dispenser incl. 8 mm strip, sponge, mixing stick, roller grid, lambskin roller, sanding pad, sanding paper, Vogl screw head and repair filler, plastic filling knife, Vogl perforated panel screws incl. bit

Use a coarse sanding pad to remove any protruding pcs. of plasterboard. Only sand in the direction of the joint.

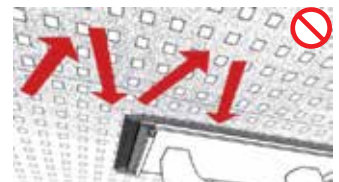
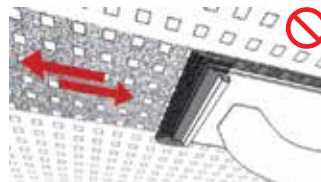
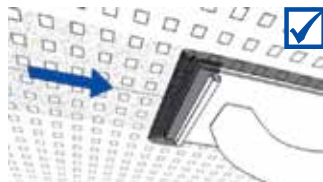

Slightly dampen the joint area using the sponge, but avoid excessive wetting of acoustic design panels.

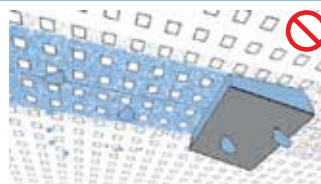
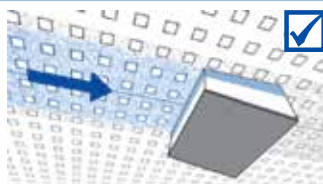

Ensure the liquid joint coating is evenly distributed on the lambskin roller by rolling downwards over the roller grid supplied.



Vogl Liquid joint coating = Ready mix

General site conditions/Manufacturer's instructions:

- Only store liquid joint coating in a ** frost free environment **
- Close liquid joint coating containers securely during long breaks
- Stir liquid joint coating well before use!
- Working temperature should be at least +10 °C and job site temperature not below +5 °C
- Avoid sudden heating and cooling of rooms
- Relative humidity: 40 - 80 %
- The ceiling framework must be installed level and be adequately rigid
- Self-levelling, cement or asphalt screeds must be fully dried – no residual moisture
- Jointing strips must only be applied "edge to edge", i.e. no overlapping

Apply the liquid joint coating using the lambskin roller. The fine texture of the lambskin roller must be visible.

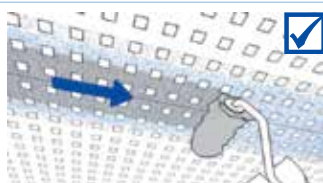

Fix the strip, with the rubber side towards the board, in the middle of the joint which is already wet with liquid coating. Using your left thumb press on the strip until the coating comes out from both sides of the strip, bringing your left thumb along the strip to meet your right thumb. Follow the same procedure for the next joint.



Subsequently coat the joint area generously with liquid joint coating roll the lambskin roller over the joint, applying slight pressure. The texture of the lambskin roller must be clearly visible.

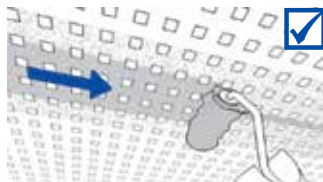

System's drying time: 12 hrs

Surface treatment by painters

(in accordance with ATV (General technical specifications in construction contracts) DIN 18363):

- Only apply coating by roller, spray application is not permitted!
- Prior to application of paint coat, a primer should generally be applied in accordance with manufacturer's specifications
- Recommended manufacturer's drying times for both primer and finishing coat must be strictly adhered to
- Alkaline coatings are unsuitable for gypsum plasterboards
- 3 coats of paint must be applied (1 prime coat + 2 finishing coats), and recommended drying times adhered to
- Always observe the system manufacturers' data sheets for primers and finishing coats

While the joints are drying use the time to fill the remaining screw heads in the field of the boards using screw head and repair filler.

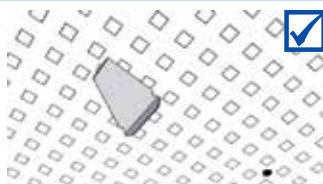

Once the joints have fully dried, gently sand the texture left by the lambskin roller using the sanding paper. Only sand in the direction of the joint: do not cross sand!

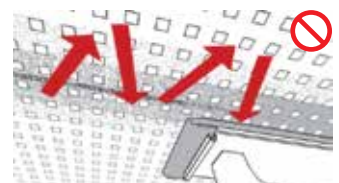
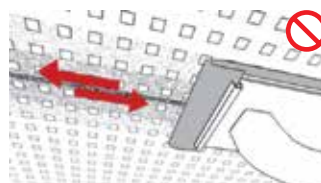
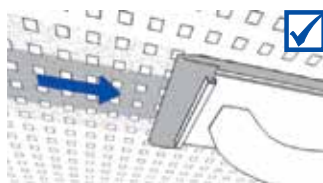

Acoustic design panels
(with air purification effect) – VoglFuge® system

Suspended ceiling structure, clad with Vogl acoustic design panels backed with sound absorbing fleece, mounted to a rigid ceiling framework of galvanised metal profiles, hung with flush and horizontally aligned suspended brackets and installed using materials and fixtures approved by the building authorities, designed in accordance with manufacturer's instructions, including all connection and jointing work as well as connection and fixing materials.

System structure

Framework in accordance with DIN 18181:2007-02

Profiles:

Pressure-resistant design made from galvanised sheet steel profiles CD 60/27 as primary and secondary profiles in accordance with EN 14195

Suspended brackets:

- Suspended brackets with vernier systems (top, vernier hanger),*
- Suspended brackets with vernier systems (top, base),*
- Suspended brackets with direct suspended brackets,*
- Use fixing materials approved by the relevant building authorities.

Connection:

Use cross connectors for primary-secondary profile connection, suspended brackets and cross connectors in accordance with EN 13964,

suspended bracket centre distance: max. 900 mm,
primary profile centre distance: max. 1,100 mm,
secondary profile centre distance: 250/330/333 mm*

Covering:

Vogl acoustic design panels are perforated ceiling panels in accordance with EN 14190, with air purification effect, one layer 12.5 mm, laid edge to edge and fixed to the framework using perforated panel screws SN 30, with screw spacing max. 170 mm.

Perforation pattern/perforated area/mass per unit area:

- 6/18 round/8.7 %/9.1 kg/m²*
- 8/18 round/15.5 %/8.5 kg/m²*
- 10/23 round/14.8 %/8.5 kg/m²*
- 12/25 round/18.1 %/8.2 kg/m²*
- 15/30 round/19.6 %/8.0 kg/m²*
- 8/12/50 round/13.1 %/8.7 kg/m²*
- 12/20/66 round/19.6 %/8.0 kg/m²*
- 8/18 square/19.8 %/8.0 kg/m²*
- 12/25 square/23.0 %/7.7 kg/m²*
- 8/15/20 round/9.5 %/9.1 kg/m²*
- 12/20/35 round/11.0 %/8.9 kg/m²*

Distributed load:

- Less than or equal to 0.15 kN/m²*
- Less than or equal to 0.30 kN/m²*

Fleece backing:

Panels backed with sound absorbing fleece as:

- Acoustic fleece, black,*
- Acoustic fleece, white,*

Joint finishing / filling:

Fill screw heads using Vogl screw head and repair filler flush with the surface. Carry out joint finishing using the VoglFuge® system in accordance with manufacturer's instructions.

Subbase:

Suspension height: h = mm
Installation height: h = mm
Room height: h = mm
Insulation thickness: th = mm

Complete system: Vogl Deckensysteme, or equivalent

* Delete as applicable





Visible Chamfer



Visible Joints

Clean Lines

with air purification
effect as standard

Quick panel assembly without joint filling

Easy, quick, reliable

Large-sized acoustic ceilings can finally be implemented completely without any joint finishing operations. The Visible Chamfer system from Vogl Deckensysteme now provides an economic solution for the acoustic design of particularly crack-prone ceilings. But the applicability of the Visible Chamfer is not limited to crack-prone areas, it can also be used to deliberately create grid design of the ceiling which can, for instance, be mirrored by other elements of the room. Gymnasiums with their extra-high ceilings now also benefit from a quick and clean solution that works without any joint finishing operations.



Benefits of the Visible Chamfer system:

The circumferential Visible Chamfer (3 x 3 mm) of the acoustic design ceiling enables fast and cost-efficient installation without joint finishing:

- Quick mounting of panels – edge to edge
- Significant time savings
- No joint finishing necessary
- Maximum crack resistance due to virtually jointless design
- With standard air purification effect
- Ceilings ready for painting within shortest time

Framework



Ceiling panel



Finish



The all-in-one system reliability – upon request, Vogl Deckensysteme will deliver all materials required to produce ceilings with finished surfaces. High-quality building materials from framework to finishing assure top results at the assembly site.



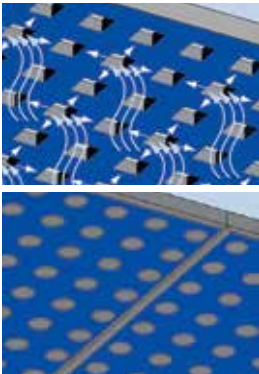

Visible Chamfer acoustic design panels by Vogl are perforated ceiling panels with high acoustic performance and air purification effect (adsorption). Black or white acoustic fleece backing (other fleece colours on request), four-side sharp-edged as a visible chamfer for installation by means of the quickest and most reliable edge to edge installation principle.

Other available options: Vogl acoustic design panels with non-perforated edges, block perforation, applications, manufactured in accordance with customer designs and ceiling plans.

Standards: EN 14190 "Gypsum plasterboard products from reprocessing"
Material class: A2-s1, d0 (non-combustible) according to EN 13501
Long edge: Visible Chamfer 3 x 3 mm
Short edge: Visible Chamfer 3 x 3 mm

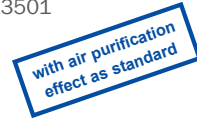
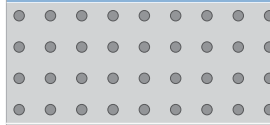
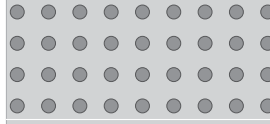
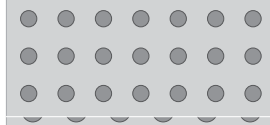
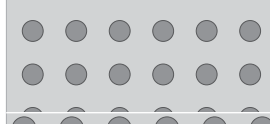
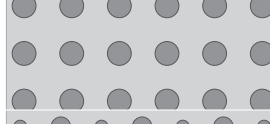
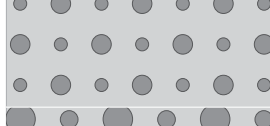







Illustration	Item number	Description	Details	m ² /pallet Panels/pallet
	7101101110	Acoustic design panel Visible Chamfer 6/18R Acoustic fleece, black	1188 x 1998 x 12.5 mm	59.3 m ²
	7101101120	Acoustic design panel Visible Chamfer 6/18R Acoustic fleece, white	Perforated area: 8.7% Mass: 9.1 kg/m ²	25 pcs.
	7101102110	Acoustic design panel Visible Chamfer 8/18R Acoustic fleece, black	1188 x 1998 x 12.5 mm	59.3 m ²
	7101102120	Acoustic design panel Visible Chamfer 8/18R Acoustic fleece, white	Perforated area: 15.5% Mass: 8.5 kg/m ²	25 pcs.
	7101103110	Acoustic design panel Visible Chamfer 10/23R Acoustic fleece, black	1196 x 2001 x 12.5 mm	59.8 m ²
	7101103120	Acoustic design panel Visible Chamfer 10/23R Acoustic fleece, white	Perforated area: 14.8% Mass: 8.5 kg/m ²	25 pcs.
	7101104110	Acoustic design panel Visible Chamfer 12/25R Acoustic fleece, black	1200 x 2000 x 12.5 mm	60.0 m ²
	7101104120	Acoustic design panel Visible Chamfer 12/25R Acoustic fleece, white	Perforated area: 18.1% Mass: 8.2 kg/m ²	25 pcs.
	7101105110	Acoustic design panel Visible Chamfer 15/30R Acoustic fleece, black	1200 x 1980 x 12.5 mm	59.4 m ²
	7101105120	Acoustic design panel Visible Chamfer 15/30R Acoustic fleece, white	Perforated area: 19.6% Mass: 8.0 kg/m ²	25 pcs.
	7101106110	Acoustic design panel Visible Chamfer 8/12/50R Acoustic fleece, black	1200 x 2000 x 12.5 mm	60.0 m ²
	7101106120	Acoustic design panel Visible Chamfer 8/12/50R Acoustic fleece, white	Perforated area: 13.1% Mass: 8.7 kg/m ²	25 pcs.
	7101107110	Acoustic design panel Visible Chamfer 12/20/66R Acoustic fleece, black	1188 x 1980 x 12.5 mm	58.8 m ²
	7101107120	Acoustic design panel Visible Chamfer 12/20/66R Acoustic fleece, white	Perforated area: 19.6% Mass: 8.0 kg/m ²	25 pcs.
	7101108110	Acoustic design panel Visible Chamfer 8/18Q Acoustic fleece, black	1188 x 1998 x 12.5 mm	59.3 m ²
	7101108120	Acoustic design panel Visible Chamfer 8/18Q Acoustic fleece, white	Perforated area: 19.8% Mass: 8.0 kg/m ²	25 pcs.
	7101109110	Acoustic design panel Visible Chamfer 12/25Q Acoustic fleece, black	1200 x 2000 x 12.5 mm	60.0 m ²
	7101109120	Acoustic design panel Visible Chamfer 12/25Q Acoustic fleece, white	Perforated area: 23.0% Mass: 7.7 kg/m ²	25 pcs.
	7101110110	Acoustic design panel Visible Chamfer 8/15/20R Acoustic fleece, black	1200 x 2000 x 12.5 mm	60.0 m ²
	7101110120	Acoustic design panel Visible Chamfer 8/15/20R Acoustic fleece, white	Perforated area: 9.5% Mass: 9.1 kg/m ²	25 pcs.
	7101111110	Acoustic design panel Visible Chamfer 12/20/35R Acoustic fleece, black	1200 x 2000 x 12.5 mm	60.0 m ²
	7101111120	Acoustic design panel Visible Chamfer 12/20/35R Acoustic fleece, white	Perforated area: 11.0% Mass: 8.9 kg/m ²	25 pcs.

The primary profiles are rigidly hung from the structural soffit with suspended brackets using fixing materials approved by the relevant building authorities.

The centre distance and the number of suspended brackets as well as the fixing material are subject to site requirements and EN 13964/ DIN 18181. The CD 60/27 secondary profiles are attached to the primary profiles CD 60/27 using cross connectors.

CD 60/27 are extended using straight connectors. For primary grid profiles, always ensure that the joint is close to a suspended bracket (max. 100 mm). Joints should be staggered.

The plasterboards should be installed in accordance with EN 13964/ DIN 18181 and the manufacturer's guidelines.

Additional items such as lighting, ventilation, sprinkler systems etc. must be individually suspended.

Any changes in the framework resulting from additional ceiling mounted items must be considered.

Visible Chamfer framework								
Technical data	Unit	Perforated panel ceiling						
Panel thickness	mm	12.5						
Distributed load	kN/m ²	≤ 0.15					≤ 0.30	
Centre distance of suspended bracket A	mm	1150	1050	1000	950	900	900	750
Centre distance of primary profiles X	mm	600	800	900	1000	1100	600	1000
Centre distance of secondary profiles Y	mm	see table below						

Article	Unit	Centre distance of secondary profiles Y
Acoustic design panel 6/18; 8/18; 8/18Q; 10/23; 12/25; 12/25Q; 8/12/50; 8/15/20; 12/20/35	mm	333
Acoustic design panel 15/30; 12/20/66	mm	330

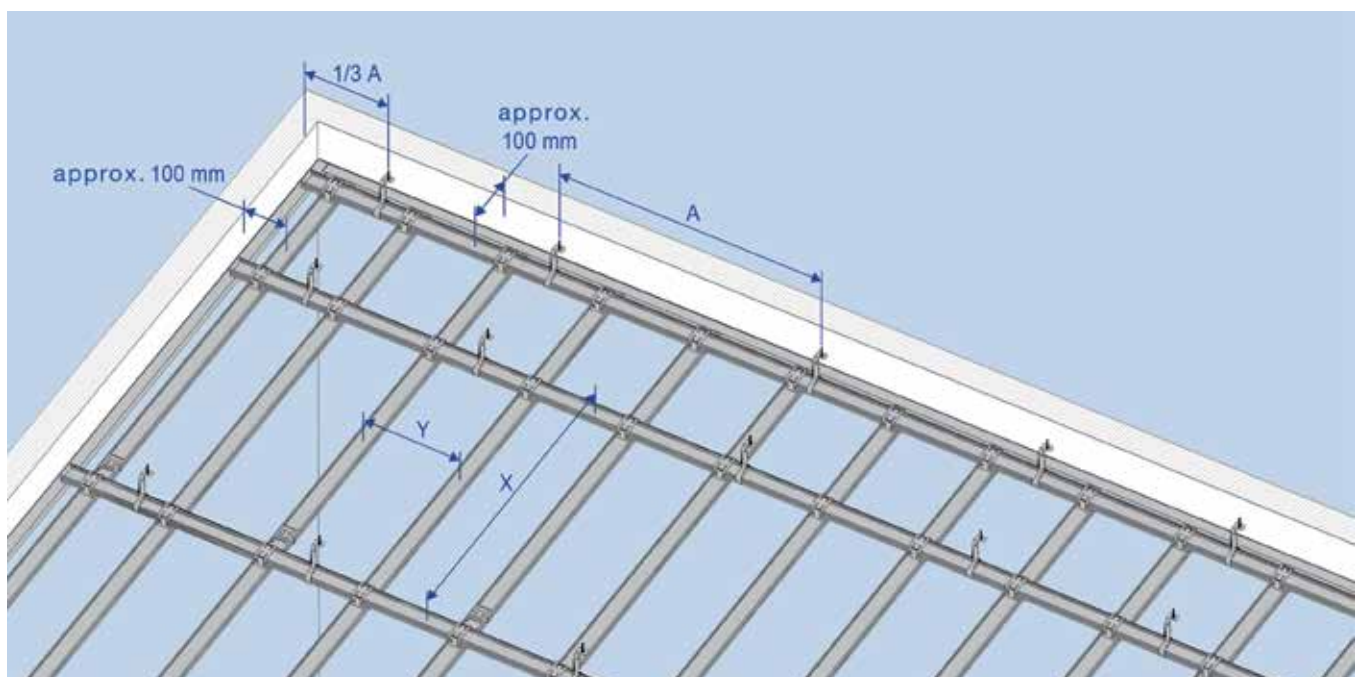

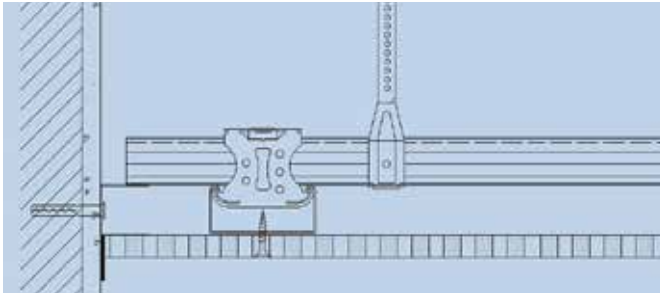

Wall connection – rigid

For rigid wall connections, a double layer fleece strip is used to separate the acoustic ceiling from the wall.

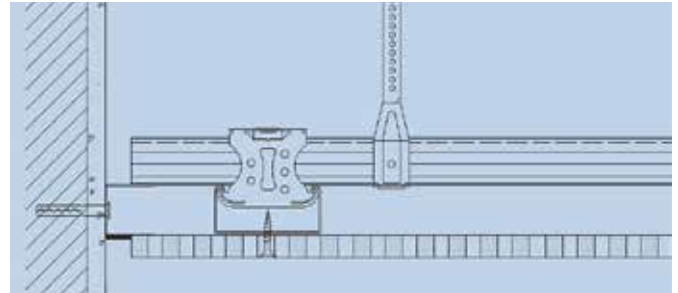

Wall connection – shadow gap

For wall connections with a shadow gap the panel is only installed up to the UD profile as this may be covered with a strip of adhesive double layer fleece in order to colour the shadow gap.

Please contact us if you require additional technical details on possible wall connections.

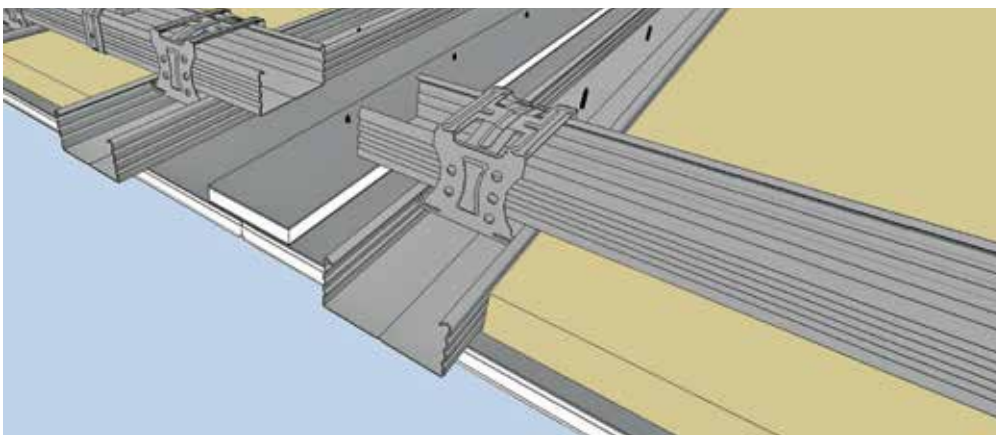

Expansion joints:

To prevent cracking in the ceiling surface, expansion joints have to be provided every 15 linear metres/150 m² of the ceiling area.

The framework must be completely severed (see illustration) and the panel strips above the joint fixed to one side of the ceiling construction only.

Tip: The panel strip may be covered with adhesive double layer fleece on the visible side if colouring the expansion joint in either black or white is desired.

Material required per m² based on a ceiling of 100 m² (10 m x 10 m, not considering loss or waste, approximate values):

Metal framework, suspended bracket centre distance 1000 mm, primary profile spacing 900 mm, secondary profile spacing 333 mm

Article no.	Article description	Unit	Quantity
Fixation			
Standard	Safety nail, DN 6 x 35	pcs.	1.3
Suspended bracket			
2016X000	Direct suspended bracket 50/120/200 and	pcs.	1.3
50809000	Tapping screw LN 3.5 x 9.5	pcs.	2.6
or			
20128 / 20151	Vernier hanger/vernier bottom part and	pcs.	1.3
25501000	Vernier safety bolt and	pcs.	1.3
25XXX000	Vernier top part, 200 - 2000 mm, custom lengths on request	pcs.	1.3
Profiles and connectors			
100XX000	CD profile 60/27/0.6 rK, L=XXX mm	m	4.1
10230000	UD profile 28/27/0.6, 3000 mm	m	0.4
20159000	Connector, lengthwise, CD 60/27	pcs.	0.8
20135000	Cross connector, CD 60/27	pcs.	3.3
52130000	Perforated panel screw SN 3.5 x 30	pcs.	22

Check ceiling framework for rigidity and evenness (using a straightedge).



Then check ceiling grid CD sections for centre distances and adjust if necessary. Always mount straight connectors in a staggered manner (see figure) Measure centre distances accurately!

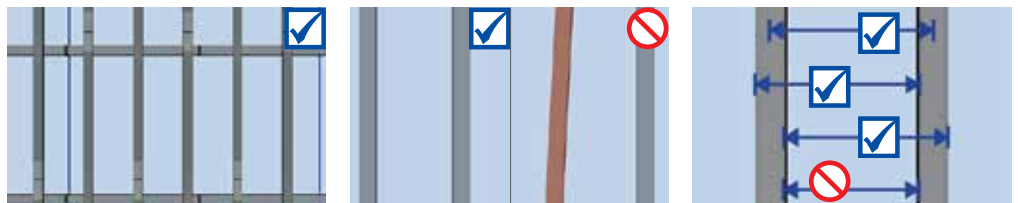

As viewed from the entrance to the area, choose the panel arrangement with short edge parallel to the windows (main direction of light).



Locate centre of the room to position the first ceiling panel, also taking into account resulting ceiling perimeter to wall connections.



We recommend the following assembly accessories:

Perforated panel screws, including screw bit

Correct handling of ceiling panels:

- Always take into account the load carrying capacity of the building when storing ceiling panels
- Do not store ceiling panels upright, but always flat on panel pallets
- Always carry ceiling panels with short edges upright
- Protect ceiling panels from moisture; relative humidity should be 40 - 80 %
- Avoid major temperature fluctuations
- Do not expose stored ceiling panels to direct sunlight

Get the panel to the correct position on the framework using a panel lifter if working alone, or otherwise with another worker's help.



Perforation pattern	Centre distance
Straight round perforation 6/18, 8/18, 10/23, 12/25 Offset round perforation 8/12/50, Straight square perforation 8/18, 12/25 Random perforation 8/15/20, 12/20/35	333 mm
Straight round perforation 15/30 Offset round perforation 12/20/66	330 mm

The screw shall be put into the panel at right angles, whereas the countersunk head shall be screwed below the visible surface of the ceiling panel except for 0.5 mm.

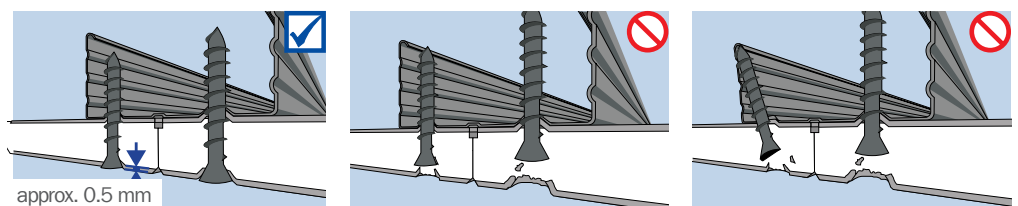

Screws should be spaced maximum 170 mm from fixing point to fixing point. The distance between the screw and the panel edge shall not exceed 26 mm. Avoid damaging acoustic design panels by countersunk heads.

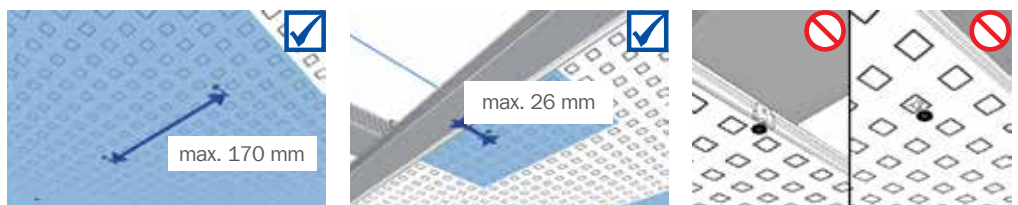

First, screw the ceiling panel to the framework in the centre of the panel, then lower the panel lifter and fix a screw in the centre of each short edge before finally screwing down long edges.



Take note of panel labelling (stamp) and mount in the direction of reading (all stamps should point in the same direction).



Use the CD profile or the straight edge as an end stop. To bring into position, slide the next panel alongside the CD profile/straight edge and fix.



General site conditions / Manufacturer's instructions:

- Take into account the expansion joints of the building structure
- Plan to include expansion joints after approx. every 15 m or approx. 150 m²
- Cardboard layer must not be penetrated by screws, but merely displaced downwards
- Working temperature should be at least +10 °C and job site temperature not below +5 °C
- Place any damping (mineral wool layer) directly onto the ceiling panels
- After installing the ceiling panels, screw heads have to be filled and sanded

Fix screws in panel joint area using alternating pairs across panels ("zig-zag" principle), starting left or right next to the screw which has already been fixed. This will create flush joint areas.

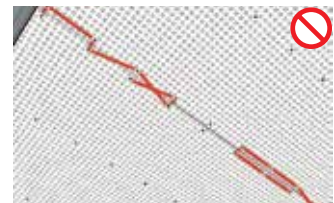
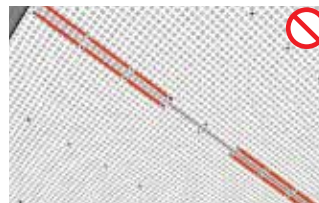
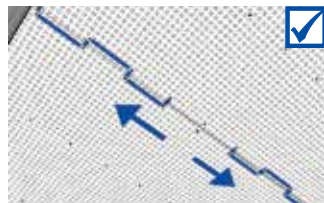

Install ceiling panels first lengthways, then crossways, resulting in a cross arrangement on the ceiling. Cover remaining areas in same manner, working from centre of room outwards.

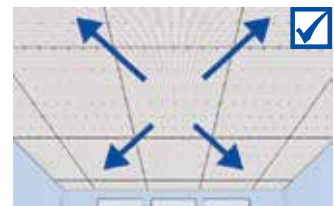

Lay the remaining ceiling panels edge to edge, always checking that the joints are level and using the "cross joint" system only.

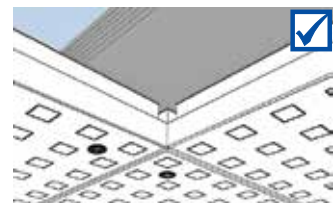
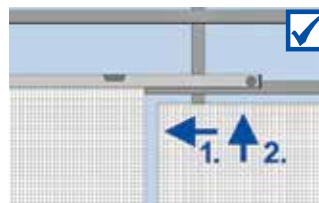

After all the panels have been installed, recheck that all joints are level and adjust, if necessary, using a screwdriver. Then check with a straight edge.

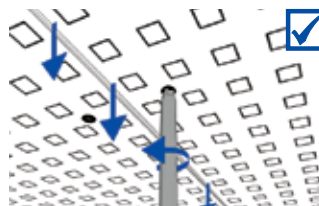

Place any damping layer directly onto back of ceiling panels. Never screw into the UD28 profile when mounting panels at the ceiling perimeter.

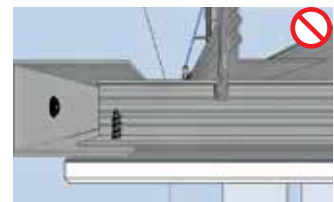
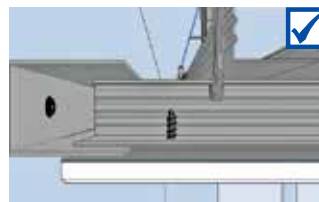
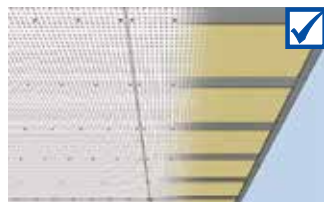

Provide for an expansion joint of 5 - 10 mm every 15 linear metres/150 m².



The additional board strips above the joint must only be fixed on one side.

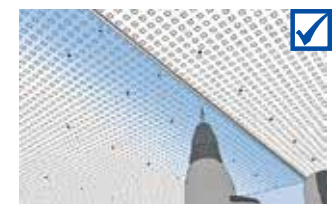

Acoustic design panels
(with air purification effect) – Visible Chamfer System

Suspended ceiling structure, clad with Vogl acoustic design panels on one side, backed with sound absorbing fleece, mounted to a rigid ceiling framework of galvanised metal profiles, hung with flush and horizontally aligned suspended brackets and installed using materials and fixtures approved by the building authorities, with or without damping layer depending on structural requirements, implemented in accordance with manufacturer's instructions, including all connection and jointing work as well as connection and fixing materials.

System structure

Framework in accordance with DIN 18181:2007-02

Profiles:

Pressure-resistant design made from galvanised sheet steel profiles CD 60/27 as primary and secondary profiles in accordance with EN 14195

Suspended brackets:

- Suspended brackets with vernier systems (top, vernier hanger),*
- Suspended brackets with vernier systems (top, base),*
- Suspended brackets with direct suspended brackets, *
- Use fixing materials approved by the relevant building authorities.

Connection:

Use cross connectors for primary-secondary profile connection, suspended brackets and cross connectors in accordance with EN 13964,

suspended bracket centre distance: max. 900 mm,
primary profile centre distance: max. 1100 mm,
secondary profile centre distance: 330 mm / 333 mm.*

Covering:

Acoustic design panels with Visible Chamfer are perforated ceiling panels in accordance with EN 14190, one layer 12.5 mm, laid edge to edge and fixed to the framework using SN 30 perforated panel screws, with screw spacing max. 170 mm. Vogl acoustic design panels with Visible Chamfer are delivered with a circumferential 3 mm chamfer at the panel edges which allows them to be laid edge to edge without joints. When installing the panels, the room layout has to be planned carefully since the laying grid will be visible after finishing drywall construction due to the Visible Chamfer.

Perforation pattern/perforated area/mass per unit area:

- 6/18 round/8.7 %/9.1 kg/m² *
- 8/18 round/15.5 %/8.5 kg/m² *
- 10/23 round/14.8 %/8.5 kg/m² *
- 12/25 round/18.1 %/8.2 kg/m² *
- 15/30 round/19.6 %/8.0 kg/m² *
- 8/12/50 round/13.1 %/8.7 kg/m² *
- 12/20/66 round/19.6 %/8.0 kg/m² *
- 8/18 square/19.8 %/8.0 kg/m² *
- 12/25 square/23.0 %/7.7 kg/m² *
- 8/15/20 round/9.5 %/9.1 kg/m² *
- 12/20/35 round/11.0 %/8.9 kg/m² *

Distributed load:

- Less than or equal to 0.15 kN/m² *
- Less than or equal to 0.30 kN/m² *

Fleece backing:

Panels backed with sound absorbing fleece as:

- Acoustic fleece, black, *
- Acoustic fleece, white, *

Joint finishing/filling:

Fill screw heads with joint compound flush with the surface and sand. The Visible Chamfer System does not require any additional joint finishing.

Subbase:

Suspension height: h = mm
Installation height: h = mm
Room height: h = mm
Insulation thickness: th = mm

Complete system: Vogl Deckensysteme, or equivalent

* Delete as applicable



GSG4 Joint

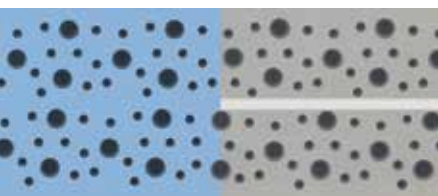

The Evolution

in Joint Filling Technology

GreatSwift Genius
- with 4 sturdy butt edges

with air purification
effect as standard

The evolution of the compound seam

For the installation of seamless acoustic ceilings, the compound seam has become established in the market with all its strengths and weaknesses.

Therefore, Vogl Deckensysteme decided that there is room for improvement.

By means of high-precision panel production and newly defined accuracy, Vogl Deckensysteme has developed a quick compound seam for acoustic ceilings in order to meet market requirements.

The result is impressive - the new Vogl GSG4 joint.
From practical experience - for practical use!

Advantages of the GSG4 joint system:

The surrounding rebate of the acoustic design panel allows quick installation and easy joint finishing:

- Less waste at the borders due to 4-side edge design
- Factory primed edges - ready for finishing
- Sturdy butt edges without any weak points
- Finishing possible with all common fillers in compliance with manufacturer's instructions

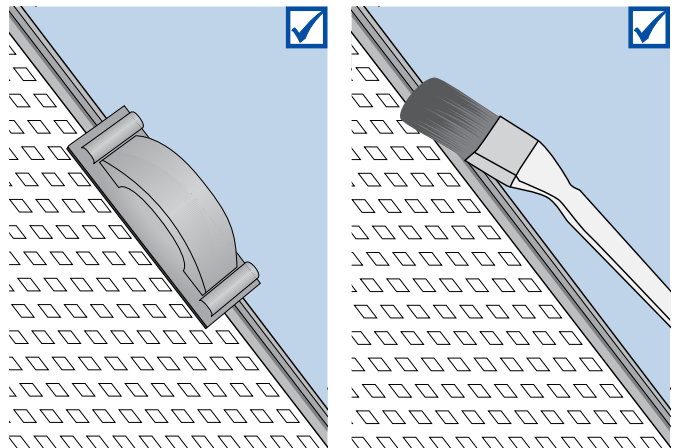
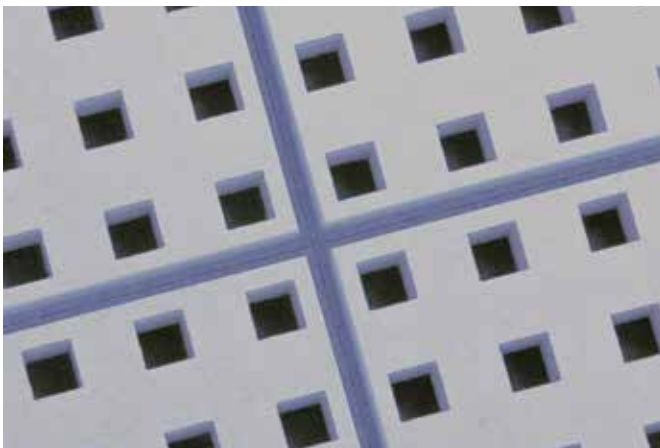
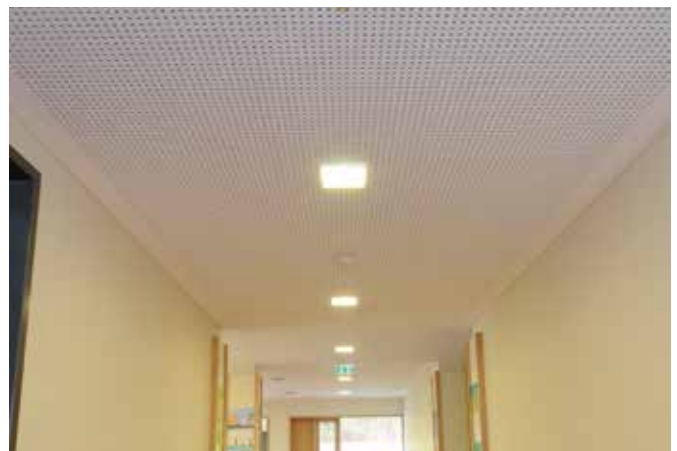

To achieve an optimum of time saving on the site, every labour-saving feature helps.

GSG4 edges are, therefore, factory-primed and the cardboard edges slightly chamfered.

For quick and easy installation on the job site – a solution from practical experience for practical use!

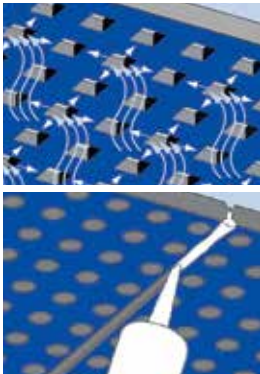

Vogl acoustic design panels GSG4 system are perforated ceiling panels with high acoustic performance and air purification effect (adsorption).

Black or white acoustic fleece backing (other fleece colours on request).

Other available options: Vogl acoustic design panels with non-perforated edges, block perforation, applications, manufacture in accordance with customer designs and ceiling plans.

Standards: EN 14190 "Gypsum plasterboard products from reprocessing"
Material class: A2-s1, d0 (non-flammable) according to EN 13501
Long edge: GSG4 edge
Short edge: GSG4 edge



Illustration	Item number	Description	Details	m ² /pallet Panels/pallet
	7081101110	Acoustic design panel GSG4 6/18R Acoustic fleece, black	1188 x 1998 x 12.5 mm	59.3 m ²
	7081101120	Acoustic design panel GSG4 6/18R Acoustic fleece, white	Perforated area: 8.7 % Mass: 9.1 kg/m ²	25 pcs.
	7081102110	Acoustic design panel GSG4 8/18R Acoustic fleece, black	1188 x 1998 x 12.5 mm	59.3 m ²
	7081102120	Acoustic design panel GSG4 8/18R Acoustic fleece, white	Perforated area: 15.5 % Mass: 8.5 kg/m ²	25 pcs.
	7081103110	Acoustic design panel GSG4 10/23R Acoustic fleece, black	1196 x 2001 x 12.5 mm	59.8 m ²
	7081103120	Acoustic design panel GSG4 10/23R Acoustic fleece, white	Perforated area: 14.8 % Mass: 8.5 kg/m ²	25 pcs.
	7081104110	Acoustic design panel GSG4 12/25R Acoustic fleece, black	1200 x 2000 x 12.5 mm	60.0 m ²
	7081104120	Acoustic design panel GSG4 12/25R Acoustic fleece, white	Perforated area: 18.1 % Mass: 8.2 kg/m ²	25 pcs.
	7081105110	Acoustic design panel GSG4 15/30R Acoustic fleece, black	1200 x 1980 x 12.5 mm	59.4 m ²
	7081105120	Acoustic design panel GSG4 15/30R Acoustic fleece, white	Perforated area: 19.6 % Mass: 8.0 kg/m ²	25 pcs.
	7081106110	Acoustic design panel GSG4 8/12/50R Acoustic fleece, black	1200 x 2000 x 12.5 mm	60.0 m ²
	7081106120	Acoustic design panel GSG4 8/12/50R Acoustic fleece, white	Perforated area: 13.1 % Mass: 8.7 kg/m ²	25 pcs.
	7081107110	Acoustic design panel GSG4 12/20/66R Acoustic fleece, black	1188 x 1980 x 12.5 mm	58.8 m ²
	7081107120	Acoustic design panel GSG4 12/20/66R Acoustic fleece, white	Perforated area: 19.6 % Mass: 8.0 kg/m ²	25 pcs.
	7081108110	Acoustic design panel GSG4 8/18Q Acoustic fleece, black	1188 x 1998 x 12.5 mm	59.3 m ²
	7081108120	Acoustic design panel GSG4 8/18Q Acoustic fleece, white	Perforated area: 19.8 % Mass: 8.0 kg/m ²	25 pcs.
	7081109110	Acoustic design panel GSG4 12/25Q Acoustic fleece, black	1200 x 2000 x 12.5 mm	60.0 m ²
	7081109120	Acoustic design panel GSG4 12/25Q Acoustic fleece, white	Perforated area: 23.0 % Mass: 7.7 kg/m ²	25 pcs.
	7081110110	Acoustic design panel GSG4 8/15/20R Acoustic fleece, black	1200 x 2000 x 12.5 mm	60.0 m ² *
	7081110120	Acoustic design panel GSG4 8/15/20R Acoustic fleece, white	Perforated area: 9.5 % Mass: 9.1 kg/m ²	25 pcs.
	7081111110	Acoustic design panel GSG4 12/20/35R Acoustic fleece, black	1200 x 2000 x 12.5 mm	60.0 m ² *
	7081111120	Acoustic design panel GSG4 12/20/35R Acoustic fleece, white	Perforated area: 11.0 % Mass: 8.9 kg/m ²	25 pcs.

*Note: Despite being perforated irregularly, random perforation panels still yield a certain linear layout as the abutting panel edges must be non-perforated in any case. This is unavoidable and independent of the workmanship of the specialist contractor.

Block slot										
Design	Slot	Slots per "block"		Rim* (unslotted)		Slotted area (panel)	Panel dimensions (standard size)		Secondary profile (centre distance)	Edges
		Short	Long	Short (mm)	Long (mm)	%	Width mm	Length mm	mm	
4F	5/82/15.4SL	69	4	73.9	73.3	15.7	1200	2400	300	GSG4
8F	5/82/15.4SL	30	4	73.9	73.3	13.7	1200	2400	300	GSG4
8/16F	5/82/15.4SL	4 x 6	4	73.9	73.3	10.9	1200	2400	300	GSG4

*Edge dimensions refer to visible rim

Block perforation										
Design	Perforation	Holes per "block"		Rim* (non-perforated)		Perforated area (panel)	Panel dimensions (standard size)		Secondary profile (centre distance)	Edges
		Short	Long	Short (mm)	Long (mm)	%	Width mm	Length mm	mm	
4F	8/18R	64	30	41	41	12.9	1224	2448	312.5	GSG4
	12/25R	45	21	44	44	14.9	1200	2400	300	GSG4
	12/25Q	45	21	44	44	18.9	1200	2400	300	GSG4
8F	8/18R	30	30	41	41	12.1	1224	2448	312.5	GSG4
	12/25R	21	21	44	44	13.9	1200	2400	300	GSG4
	12/25Q	21	21	44	44	17.7	1200	2400	300	GSG4
32F	8/18R	13	13	41	41	9.1	1224	2448	312.5	GSG4
	12/25R	9	9	44	44	10.2	1200	2400	300	GSG4
	12/25Q	9	9	44	44	13.0	1200	2400	300	GSG4

*Edge dimensions refer to visible rim

Diagrams represent visible side

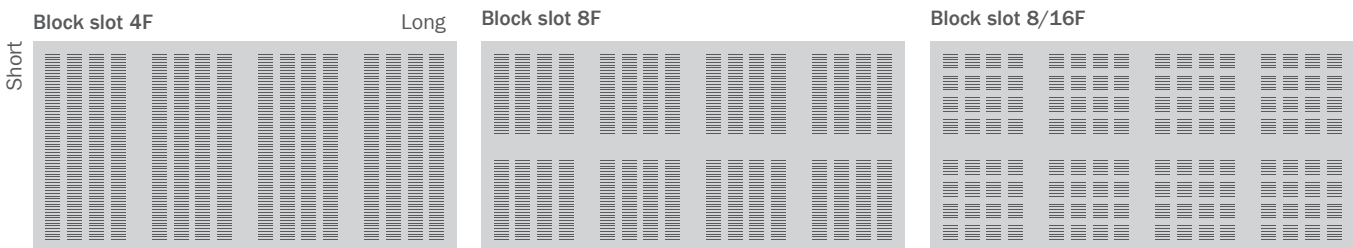

Slot only possible in longitudinal direction of the ceiling panels.

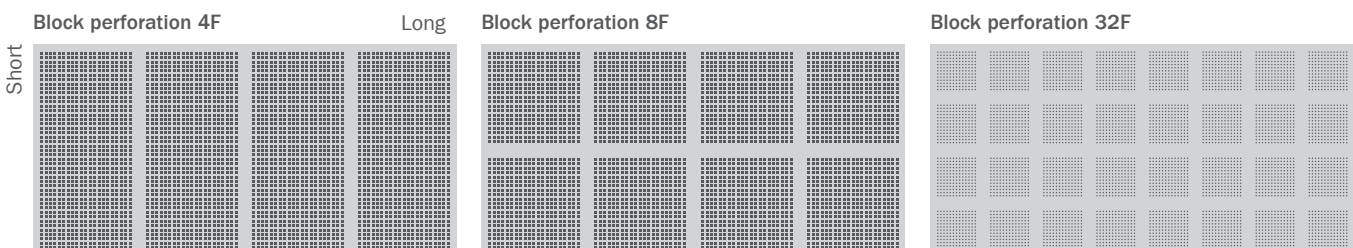

Example: 12/25Q

Example: 12/25Q

Example: 8/18R

Acoustic design panels with non-perforated rims

1 rim non-perforated

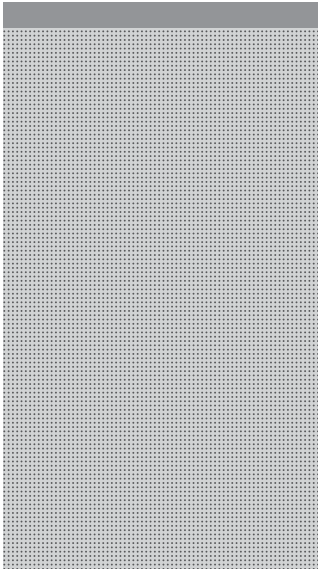

2 rims non-perforated

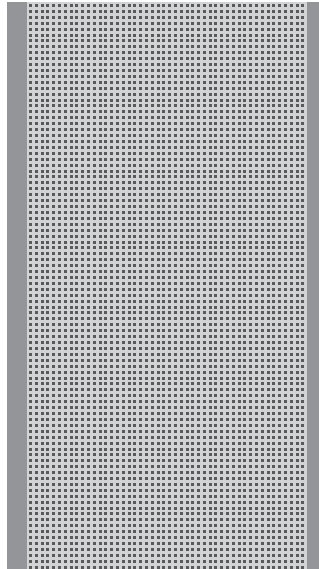

3 rims non-perforated

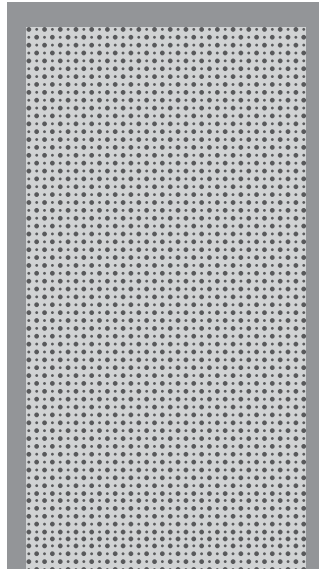

4 rims non-perforated

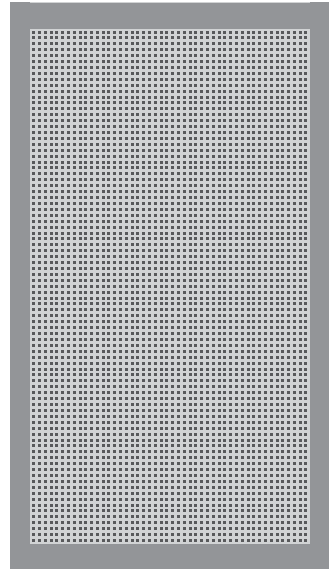

Acoustic design panels with moulded components attached

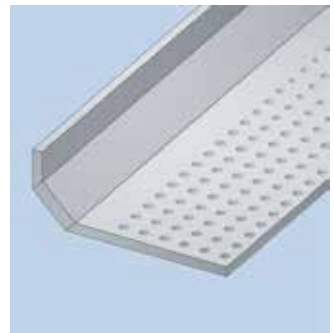
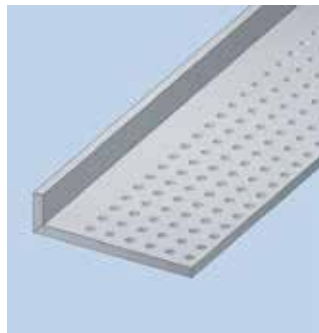
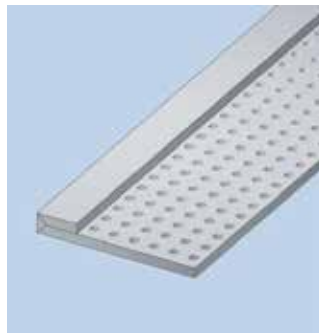
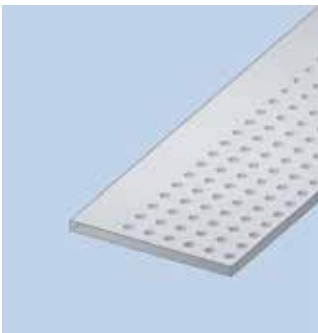

Acoustic design panels in a layout plan

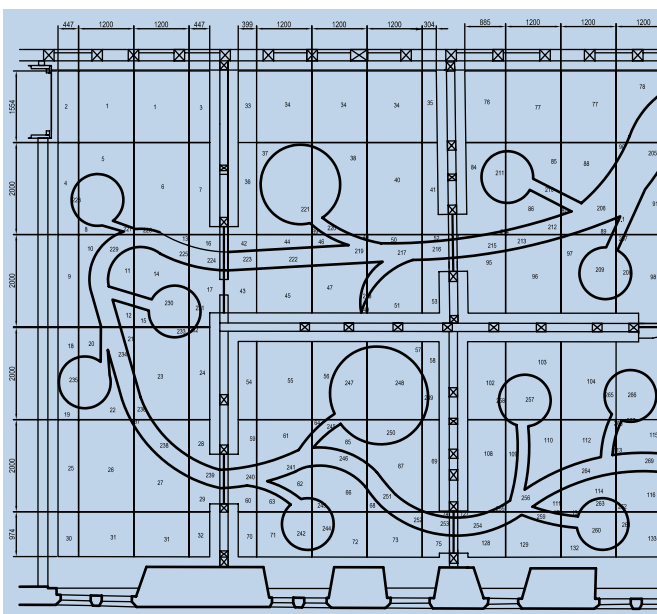

You want a ceiling that features not only high acoustic performance, but also outstanding appearance?

We are always pleased to help; our experts can adapt our acoustic design panels exactly to your desired ceiling surface. When manufacturing ceiling systems to plan, we supply the custom-made and perfectly fitted acoustic design panels as well as a layout plan for use on the job site, thus ensuring reliable results for the installation. And of course, our moulded components, stretch ceilings and ceiling components can be perfectly integrated into your planned ceiling surface.



The primary profiles are hung from the structural soffit with suspended brackets using fixing materials approved by the relevant building authorities.

The centre distance and number of suspended brackets, as well as the fixing material, are subject to site requirements and EN 13964/ DIN 18181. The CG 60/27 secondary profiles are attached to the primary profiles CD 60/27 using cross connectors.

CD 60/27 profiles are extended using straight connectors. For primary grid profiles, always ensure that the joint is close to a suspended bracket (max. 100 mm). Joints should generally be staggered.

The plasterboards should be installed in accordance with EN 13964/ DIN 18181 and the manufacturer's guidelines.

Additional items such as lighting, ventilation, sprinkler systems etc. must be individually suspended.

Any changes in the framework owing to integrated ceiling components must be considered.

Block perforations and block slots require different centre distances of the secondary profiles which are shown in our tables on page 86.

Framework for GSG4 joint								
Technical data	Unit	Perforated panel ceiling						
Panel thickness	mm	12.5						
Distributed load	kN/m ²	≤ 0.15					≤ 0.30	
Centre distance of suspended bracket A	mm	1150	1050	1000	950	900	900	750
Centre distance of primary profiles X	mm	600	800	900	1000	1100	600	1000
Centre distance of secondary profiles Y	mm	see table below						

Article	Unit	Centre distance of secondary profiles Y
Acoustic design panel 6/18; 8/18; 8/18Q; 10/23; 12/25; 12/25Q; 8/12/50; 8/15/20; 12/20/35	mm	333
Acoustic design panel 15/30 12/20/66	mm	330

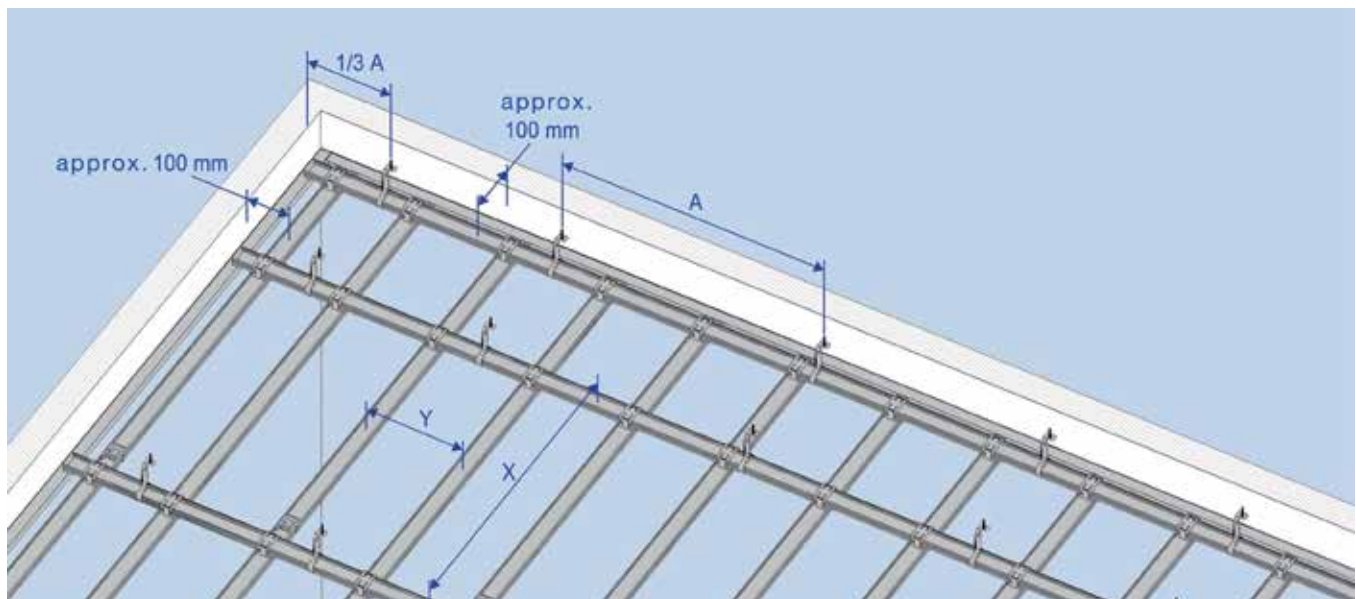

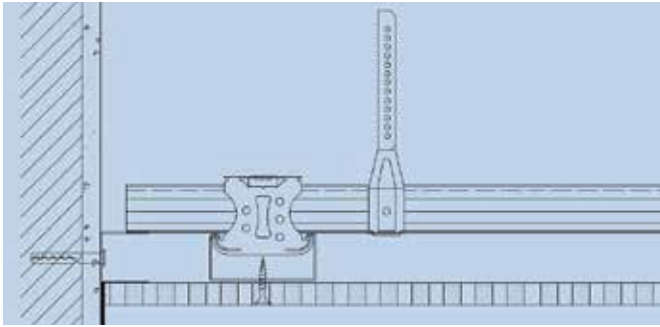

Wall connection with filled joint:

For filled wall connections, a double layer fleece strip is used to separate the acoustic ceiling from the wall.

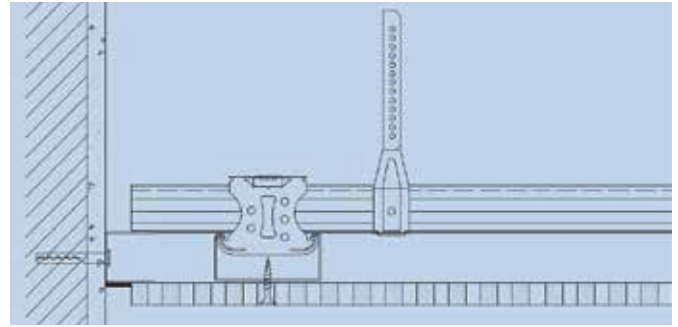

Wall connection – shadow gap:

For wall connections with a shadow gap, the panel is placed and mounted such that the desired width of the shadow gap is left free. Screwing the panel to the UD profile is not permitted as this may be covered with a strip of adhesive double layer fleece in order to colour the shadow gap.

Please contact us if you require additional technical details on possible wall connections.

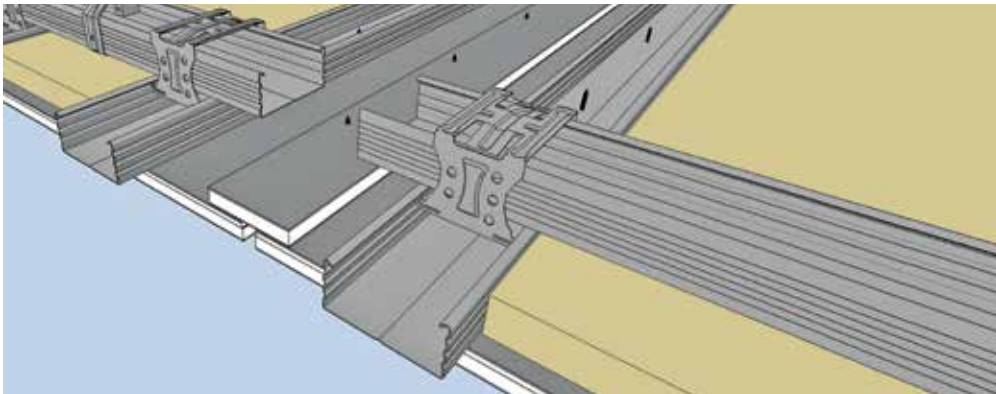

Expansion joints:

To reduce the risk of cracking in the ceiling, expansion joints should be installed every 10 linear metres / 100 m² of ceiling area.

The framework must be completely severed (see illustration) and the panel strips above the joint must only be fixed to one side.

Tip: The panel strip may be covered with adhesive double layer fleece on the visible side if colouring the expansion joint in either black or white is desired.

Material required per m² based on a ceiling of 100 m² (10 m x 10 m, without loss or waste)

Metal framework, suspended bracket centre distance 1000 mm, primary profile spacing 900 mm, secondary profile spacing 333 mm

Article no.	Article description	Unit	Quantity
Fixation			
Standard	Safety nail, DN 6 x 35	pcs.	1.3
Suspended brackets			
2016X000	Direct suspended bracket 50/120/200 and	pcs.	1.3
50809000	Tapping screw LN 3.5 x 9.5	pcs.	2.6
or			
20128 / 20151	Vernier hanger/vernier bottom part and	pcs.	1.3
25501000	Vernier safety bolt and	pcs.	1.3
25XXX000	Vernier top part, 200 - 2000 mm, custom lengths on request	pcs.	1.3
Profiles and connectors			
100XX000	CD profile 60/27/0.6 rK, L=XXX mm	m	4.1
10230000	UD profile 28/27/0.6, 3000 mm	pcs.	0.4
20159000	Connector, lengthwise, CD 60/27	pcs.	0.8
20135000	Cross connector, CD 60/27	pcs.	3.3
52130000	Perforated panel screw SN 3.5 x 30	pcs.	22

Check ceiling framework for rigidity and evenness (using a straightedge).



Then check ceiling grid CD sections for centre distances and adjust, if necessary. Always mount straight connectors in a staggered manner (see figure) Measure centre distances accurately!

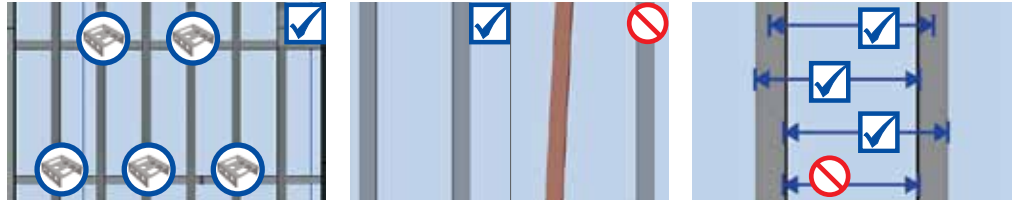

As viewed from the entrance area, choose the panel arrangement with short edges parallel to the windows (main direction of light).



Locate centre of the room to position the first ceiling panel, also taking into account resulting ceiling perimeter to wall connections.



We recommend the following assembly accessories:

Perforated panel screws, including screw bit

Correct handling of ceiling panels:

- Always take into account the load carrying capacity of the building when storing ceiling panels
- Do not store ceiling panels upright, but always flat on panel pallets
- Always carry ceiling panels with short edges upright
- Protect ceiling panels from moisture; relative humidity should be 40 - 80 %
- Avoid major temperature fluctuations
- Do not expose stored ceiling panels to direct sunlight

Get the panel to the correct position on the framework using a panel lifter if working alone, or else another worker's help.



Perforation pattern	Centre distance
Straight round perforation 6/18, 8/18, 10/23, 12/25 Offset round perforation 8/12/50, Straight square perforation 8/18, 12/25 Random perforation 8/15/20, 12/20/35	333 mm
Straight round perforation 15/30 Offset round perforation 12/20/66	330 mm

The screws must be put into the panel at right angles, and the countersunk head screwed down to 0.5 mm below the visible surface of the ceiling panel.

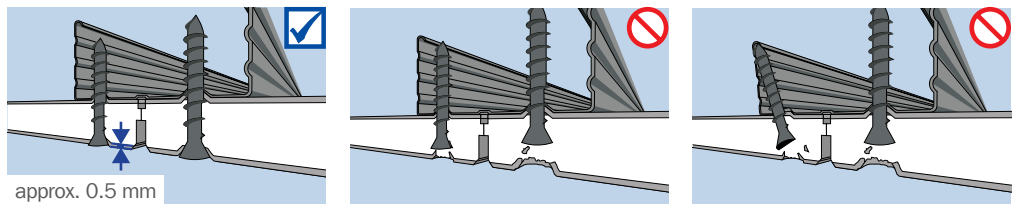

Screws should be spaced maximum 170 mm from fixing point to fixing point. The distance between the screw and the panel edge shall not exceed 26 mm. Avoid damaging acoustic design panels by countersunk heads.

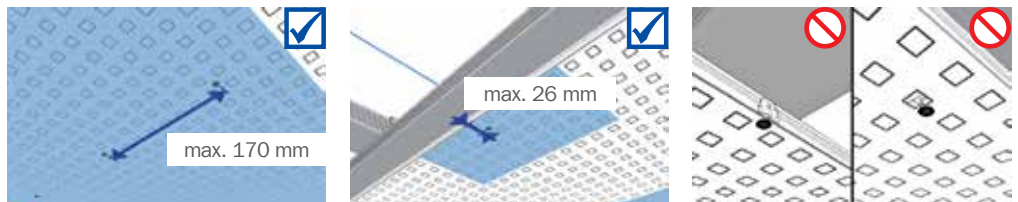

First, screw the ceiling panel to the framework in the centre of the panel, then lower the panel lifter and fix a screw in the centre of each short edge before finally screwing down long edges.



Take note of panel labelling (stamp) and mount in the direction of reading (all stamps should point in the same direction).



Install next ceiling panel edge to edge next to first panel. Use mounting aids only in case of damaged butt edges to keep proper joint size.

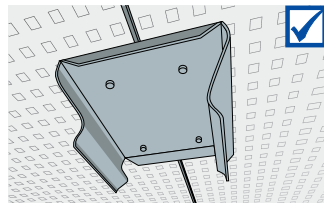

General site conditions/Manufacturer's instructions:

- Take the movement joints of the building structure into account
- Plan to include expansion joints after approx. every 10 m or approx. 100 m²
- Cardboard layer must not be penetrated by screws, but merely displaced downwards
- Working temperature should be at least +10 °C and job site temperature not below +5 °C
- Place any damping (mineral wool layer) directly onto the ceiling panels
- Carry out any additional work on ceiling (access openings, lighting recesses) immediately after installing ceiling panels and always before finishing joints

Fix screws in panel joint area using alternating pairs across panels ("zig-zag" principle), starting left or right next to the screw which has already been fixed. This will create flush joint areas.

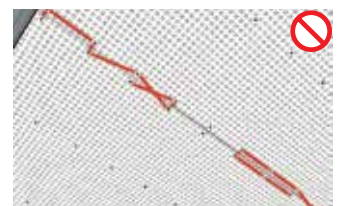
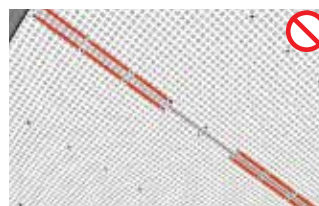
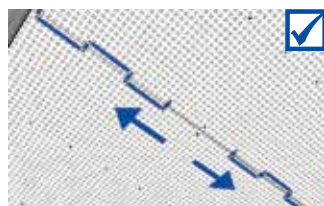

Install ceiling panels first lengthways, then crossways, resulting in a cross arrangement on the ceiling. Cover remaining areas in same manner, working from centre of room outwards.

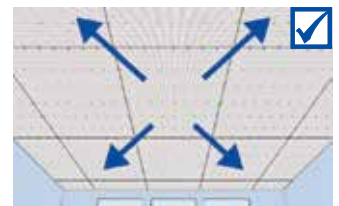

Lay the remaining ceiling panels edge-to-edge, always checking that the joints are level and exclusively using the "cross joint" system.

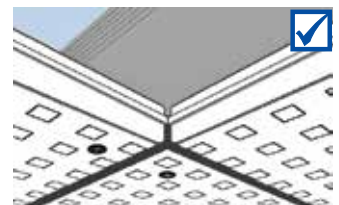
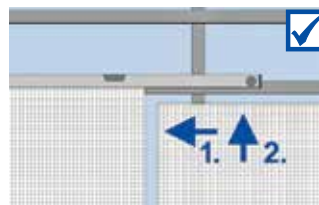

After all the panels have been installed, recheck that all joints are level and adjust, if necessary, using a screwdriver. Then check with a straightedge.

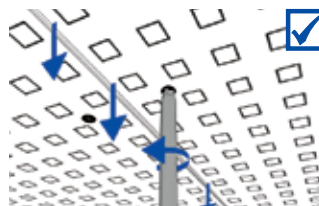
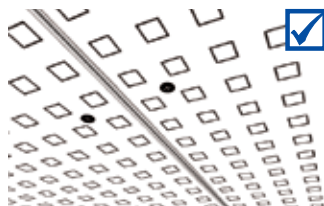

Place any damping layer directly onto back of ceiling panels
Never screw into the UD28 profile when mounting panels at the ceiling perimeter; sliding wall connections are also always required.

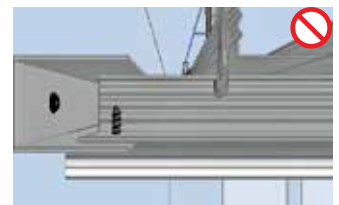
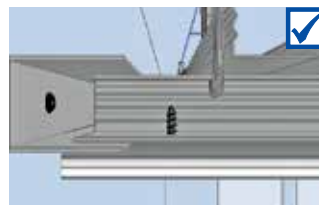
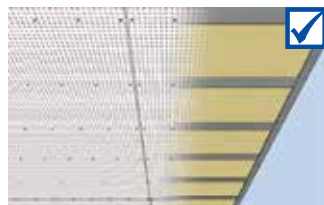

Provide for an expansion joint of 5 to 10 mm every 10 linear metres/100 m².

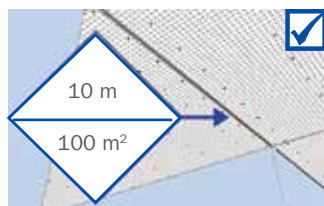

The additional board strip above the joint must be screwed down on one side only.

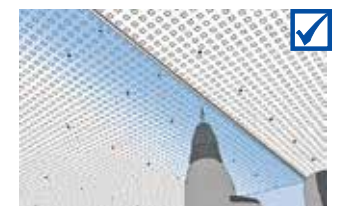

Important! All work that could result in damage to the ceiling surface must be completed before commencing jointing.

Check ceiling, adjust any height discrepancies in joint area with a screw driver.

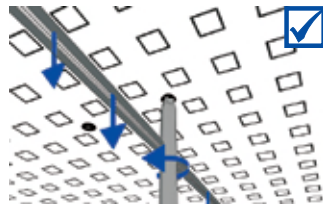

Mix joint compound in a clean pail according to manufacturer's instructions.



General site conditions / Manufacturer's instructions:

- Working temperature should be at least +10 °C and job site temperature not below +5 °C
- Avoid sudden heating and cooling of rooms
- Relative humidity: 40 - 80%
- Self-levelling, cement or asphalt screeds must be fully dried – make sure there is no residual moisture
- Use joint compound in compliance with EN 13963 (type 4B)
- Consumption of joint compound: approx. 150 g/m²

Load cartridge and fill joints generously holding cartridge as upright as possible to ensure complete filling of GSG4 joint.

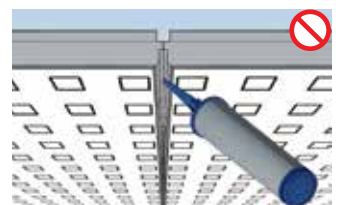

To achieve high GSG4 joint strength, take greatest care to fill joint completely and use sufficient joint compound material.

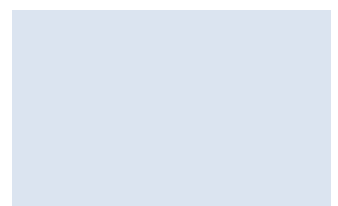
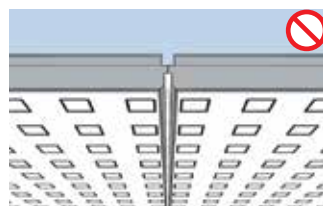
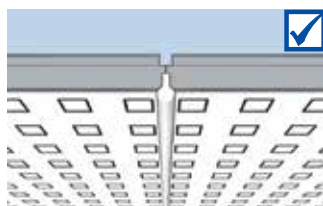

After joint compound has started to cure, and before it has hardened completely, remove any protruding material working in direction of joint.

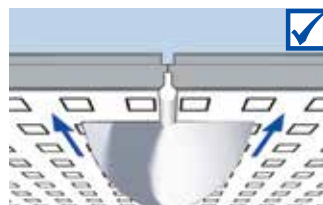
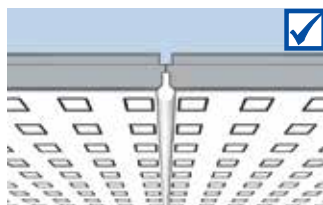

Then refill joints and screw heads with joint or finishing material, having covered perforation adjacent to joint with masking tape beforehand.

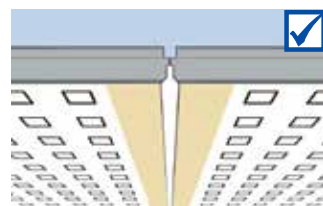

Surface treatment by painters

(in accordance with ATV (General technical specifications in construction contracts) DIN 18363, Painting and Coating Work)

- Only apply coating by roller; spray application is not permitted!
- Prior to application of paint coat, a primer should generally be applied in accordance with manufacturer's specifications
- The manufacturer's recommended drying times for both primer and finishing coat must be strictly adhered to
- Alkaline coatings are unsuitable for plasterboards
- 3 coats of paint must be applied (1 prime coat + 2 finishing coats), and recommended drying times adhered to
- Always consult system manufacturer's technical data sheets for primers and finishing coats

Any holes closed with joint compound can be re-opened using a perforation wheel.



After joint compound has completely cured, use a handheld sander to smooth the area.

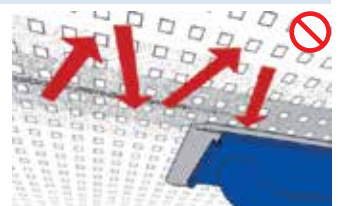
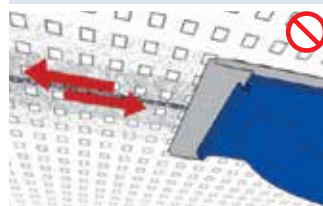
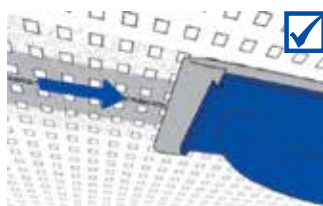

Acoustic design panels
(with air purification effect) – GSG4 joint system

Suspended ceiling structure, one side clad with Vogl acoustic design panels, backed with sound absorbing fleece, mounted to a rigid ceiling framework of galvanised metal profiles, hung with flush and horizontally aligned suspended brackets and installed using fixing materials approved by the building authorities, with or without damping layer depending on building physics requirements.

Installation in accordance with manufacturer's instructions, including all connection and jointing work as well as connection and fixing materials.

System structure

Framework in accordance with DIN 18181:2007-02

Profiles:

Pressure-resistant design made from galvanised sheet steel profiles CD 60/27 as primary and secondary profiles in accordance with EN 14195

Suspended brackets:

- Suspend with vernier systems (top part, vernier hanger),*
- Suspend with vernier systems (top / bottom part),*
- Suspend with direct suspended brackets, *
- Use fixing materials approved by the relevant building authorities.

Connection:

For primary-secondary profile connection with cross connectors, use suspended brackets and cross connectors in accordance with EN 13964,

suspended bracket centre distance: max. 900 mm,
primary profile centre distance: max. 1.100 mm,
secondary profile centre distance: 330/333 mm.*

Covering:

Vogl acoustic design panels as perforated ceiling panels in accordance with EN 14190, with air purification effect, one layer 12.5 mm, laid edge to edge and fixed to the framework using perforated panel screws SN 30, with screw spacing max. 170 mm.

Check spacing of acoustic design panels and joint sizes using appropriate mounting aids, if required.

Perforation pattern/perforated area/mass per unit area:

- 6/18 round/8.7 %/9.1 kg/m² *
- 8/18 round/15.5 %/8.5 kg/m² *
- 10/23 round/14.8 %/8.5 kg/m² *
- 12/25 round/18.1 %/8.2 kg/m² *
- 15/30 round/19.6 %/8.0 kg/m² *
- 8/12/50 round/13.1 %/8.7 kg/m² *
- 12/20/66 round/19.6 %/8.0 kg/m² *
- 8/18 square/19.8 %/8.0 kg/m² *
- 12/25 square/23.0 %/7.7 kg/m² *
- 8/15/20 round/9.5 %/9.1 kg/m² *
- 12/20/35 round/11.0 %/8.9 kg/m² *

Distributed load:

- Less than or equal to 0.15 kN/m² *
- Less than or equal to 0.30 kN/m² *

Fleece backing:

Panels backed with sound absorbing fleece as:

- Acoustic fleece, black, *
- Acoustic fleece, white, *

Joint finishing / filling:

Fill screw heads with joint compound flush with the surface and sand. Use joint compound as per EN 13963 / type 4B to finish joints in accordance with manufacturer's instructions. Acoustic design panel edges in the GSG4 joint system are factory primed and chamfered.

Complete system: Vogl Deckensysteme, or equivalent

* Delete as applicable



VOGL System Training

Our know-how for your
result reliability



Topic:

Framework for acoustic design ceilings ("perforated ceilings")

Description

A framework properly mounted to the ceiling forms the basis for a safe, flawless acoustic design ceiling that meets the regulations. In addition to theoretical fundamentals, our system training offers mainly practical guidelines for the installation work on site. Another topic of the Vogl System Training, beside suspension and connection with various components, is how to solve problems (expansion joints, integrated ceiling elements and wall connections).

Topics

- Installation of framework while heeding the applicable standards
- Various suspension systems and framework parts in theory and practice
- Distribution of the framework within the room
- Time and cost benefits when using Vogl framework
- Overview of the "problem solvers" in the ceiling area and their application
- Proper cutting of various profile systems
- Proper alignment of the framework by means of laser systems
- How to provide trimmers in the framework, e.g. for integrated ceiling components
- Expansion joints in the ceiling area/regulations and recommendations
- Various wall connections and their proper installation

Targets

After completion of the seminar, the system training participants shall

- Understand and be able to apply the current standards and regulations
- Recognise and avoid the typical installation errors
- Use the right components when incurring problems in the ceiling installation

Target group

This system training is equally suited for site and project managers as well as for drywall installers and interior construction workers. Also, technically adept employees in sales or from the building material dealers' can extend their knowledge about the proper installation of ceiling structures.



A registration form is available on page 176. You have any questions in advance? We are glad to assist you! Phone: 09104-825-100

Registration is possible by e-mailing sauchella@vogl-deckensysteme.de directly or by fax to 09104/825-280. You can also find all information on training under www.vogl-ceilingssystems.com

Compound Seam



Traditional Technology *for Filled Joints*

Compound seam by Vogl Deckensysteme
– manufactured with maximum precision

with air purification
effect as standard

Traditional technology - the compound seam

In addition to the patented VoglFuge joint system, Vogl Deckensysteme also offers the classical and most commonly used compound seam in its product line. The compound seam, too, is available in numerous perforation patterns and design variations and is naturally manufactured with maximum precision at Vogl Deckensysteme.

Other than the systems with edge to edge installation technique, this joint variation is laid with space between the panels by using mounting aids and filled afterwards with joint compound. If done properly, the joint possesses a very high degree of rigidity after curing.



Advantages of the Compound Seam:

- Proven joint technology can be performed by any drywall installer without additional training
- Due to the high quality of Vogl acoustic design panels, you get, with proper workmanship, a flawless end result
- With standard air purification effect
- Finishing possible with all common fillers in compliance with manufacturer's instructions



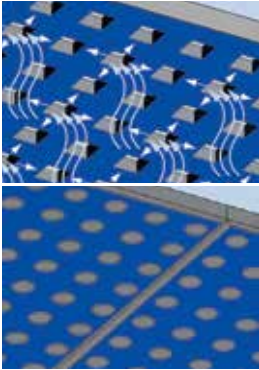

Vogl acoustic design panels compound seam system are perforated ceiling panels with high acoustic performance and air purification effect (adsorption).

Black or white acoustic fleece backing (other fleece colours on request).

Other available options: Vogl acoustic design panels with non-perforated edges, block perforation, applications, manufacture in accordance with customer designs and ceiling plans.

Other available options: Vogl acoustic design panels with non-perforated edges, block perforation, applications, manufactured in accordance with customer designs and ceiling plans.

Standards: EN 14190 "Gypsum plasterboard products from reprocessing"
Material class: A2-s1, d0 (non-combustible) according to EN 13501
Long edge: SK (sharp-edged)
Short edge: SK (sharp-edged)

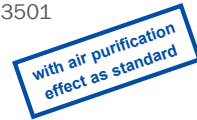
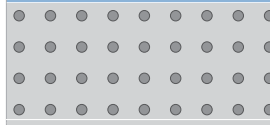
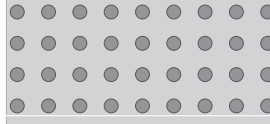
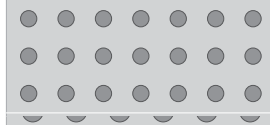
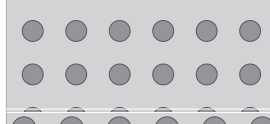

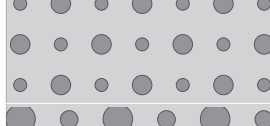

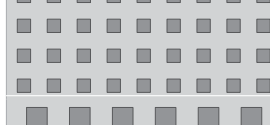





Illustration	Item number	Description	Details	m ² /pallet Panels/pallet
	7071101110	Acoustic design panel SF 6/18R Acoustic fleece, black	1188 x 1998 x 12.5 mm	59.3 m ²
	7071101120	Acoustic design panel SF 6/18R Acoustic fleece, white	Perforated area: 8.7 % Mass: 9.1 kg/m ²	25 pcs.
	7071102110	Acoustic design panel SF 8/18R Acoustic fleece, black	1188 x 1998 x 12.5 mm	59.3 m ²
	7071102120	Acoustic design panel SF 8/18R Acoustic fleece, white	Perforated area: 15.5 % Mass: 8.5 kg/m ²	25 pcs.
	7071103110	Acoustic design panel SF 10/23R Acoustic fleece, black	1196 x 2001 x 12.5 mm	59.8 m ²
	7071103120	Acoustic design panel SF 10/23R Acoustic fleece, white	Perforated area: 14.8 % Mass: 8.5 kg/m ²	25 pcs.
	7071104110	Acoustic design panel SF 12/25R Acoustic fleece, black	1200 x 2000 x 12.5 mm	60.0 m ²
	7071104120	Acoustic design panel SF 12/25R Acoustic fleece, white	Perforated area: 18.1 % Mass: 8.2 kg/m ²	25 pcs.
	7071105110	Acoustic design panel SF 15/30R Acoustic fleece, black	1200 x 1980 x 12.5 mm	59.4 m ²
	7071105120	Acoustic design panel SF 15/30R Acoustic fleece, white	Perforated area: 19.6 % Mass: 8.0 kg/m ²	25 pcs.
	7071106110	Acoustic design panel SF 8/12/50R Acoustic fleece, black	1200 x 2000 x 12.5 mm	60.0 m ²
	7071106120	Acoustic design panel SF 8/12/50R Acoustic fleece, white	Perforated area: 13.1 % Mass: 8.7 kg/m ²	25 pcs.
	7071107110	Acoustic design panel SF 12/20/66R Acoustic fleece, black	1188 x 1980 x 12.5 mm	58.8 m ²
	7071107120	Acoustic design panel SF 12/20/66R Acoustic fleece, white	Perforated area: 19.6 % Mass: 8.0 kg/m ²	25 pcs.
	7071108110	Acoustic design panel SF 8/18Q Acoustic fleece, black	1188 x 1998 x 12.5 mm	59.3 m ²
	7071108120	Acoustic design panel SF 8/18Q Acoustic fleece, white	Perforated area: 19.8 % Mass: 8.0 kg/m ²	25 pcs.
	7071109110	Acoustic design panel SF 12/25Q Acoustic fleece, black	1200 x 2000 x 12.5 mm	60.0 m ²
	7071109120	Acoustic design panel SF 12/25Q Acoustic fleece, white	Perforated area: 23.0 % Mass: 7.7 kg/m ²	25 pcs.
	7071110110	Acoustic design panel SF 8/15/20R Acoustic fleece, black	1200 x 2000 x 12.5 mm	60.0 m ² *
	7071110120	Acoustic design panel SF 8/15/20R Acoustic fleece, white	Perforated area: 9.5 % Mass: 9.1 kg/m ²	25 pcs.
	7071111110	Acoustic design panel SF 12/20/35R Acoustic fleece, black	1200 x 2000 x 12.5 mm	60.0 m ² *
	7071111120	Acoustic design panel SF 12/20/35R Acoustic fleece, white	Perforated area: 11.0 % Mass: 8.9 kg/m ²	25 pcs.

*Note: Despite being perforated irregularly, random perforation panels still yield a certain linear layout as the abutting panel edges must be non-perforated in any case. This is unavoidable and independent of the workmanship of the specialist contractor.

The primary profiles are rigidly hung from the structural soffit with suspended brackets using fixing materials approved by the relevant building authorities. The centre distance and the number of suspended brackets as well as the fixing material are subject to site requirements and EN 13964/DIN 18181. The CD 60/27 secondary profiles are attached to the primary profiles CD 60/27 using cross connectors.

CD 60/27 are extended using straight connectors. For primary grid profiles, always ensure that the joint is close to a suspended bracket (max. 100 mm). Joints should generally be staggered.

The plasterboards should be installed in accordance with EN 13964/DIN 18181 and the manufacturer's guidelines.

Additional items such as lighting, ventilation, sprinkler systems etc. must be individually suspended.

Any changes in the framework owing to integrated ceiling components must be considered.

Block perforations and block slots require different secondary profile centre distances which are shown in our tables on page 96.

Framework, Compound Seam								
Technical data	Unit	Perforated panel ceiling						
Panel thickness	mm	12.5						
Distributed load	kN/m ²	≤ 0.15					≤ 0.30	
Centre distance of suspended bracket A	mm	1150	1050	1000	950	900	900	750
Centre distance of primary profiles X	mm	600	800	900	1000	1100	600	1000
Centre distance of secondary profiles Y	mm	see table below						

Article	Unit	Centre distance of secondary profiles Y
Acoustic design panel 6/18; 8/18; 8/18Q; 10/23; 12/25; 12/25Q; 8/12/50; 8/15/20; 12/20/35	mm	333
Acoustic design panel 15/30; 12/20/66	mm	330

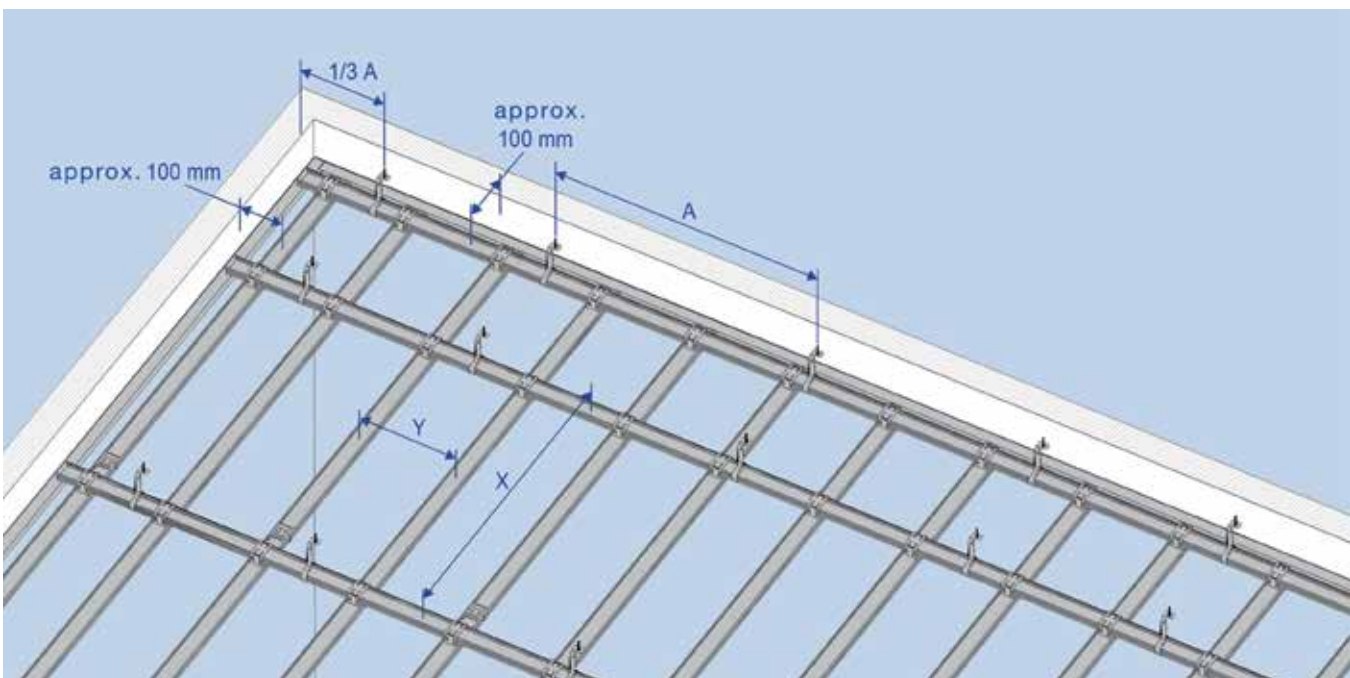

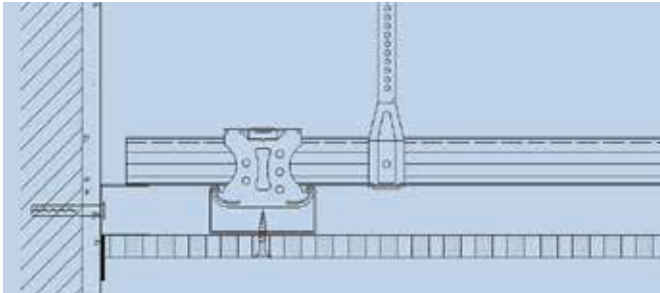

Wall connection:

For filled wall connections, or wall connections filled from below, a double layer fleece strip is used to separate the acoustic ceiling from the wall.

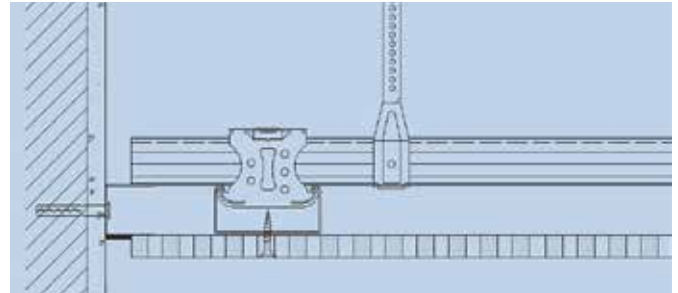

Wall connection – shadow gap:

For wall connections with a shadow gap, the panel is only installed up to the UD profile as this may be covered with a strip of adhesive double layer fleece in order to colour the shadow gap.

Please contact us if you require additional technical details on possible wall connections.

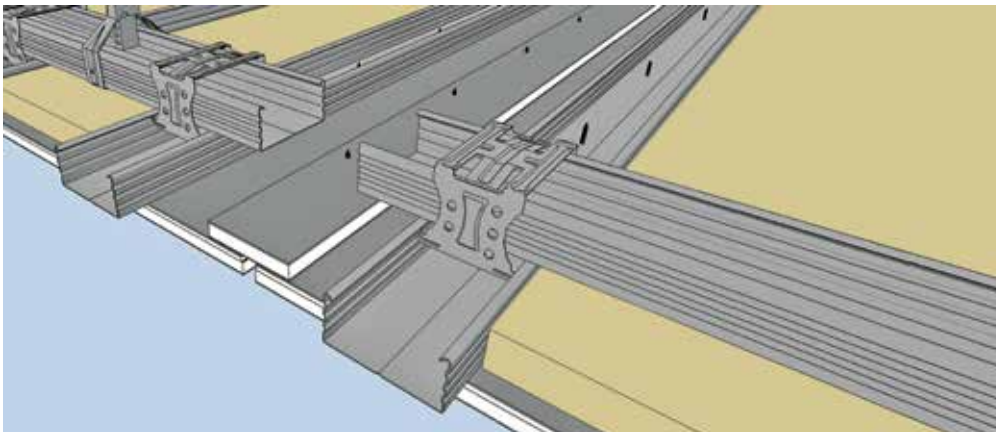

Expansion joints:

To prevent cracking in the ceiling surface, expansion joints have to be provided every 15 linear metres/150 m² of the ceiling area.

The framework must be completely severed (see illustration) and the panel strips above the joint fixed to one side of the ceiling structure only.

Tip: The panel strip may be covered with adhesive double layer fleece on the visible side if colouring the expansion joint in either black or white is desired.

Material required per m² based on a ceiling of 100 m² (10 m x 10 m, not considering loss or waste, approximate values):

Metal framework, suspended bracket centre distance 1000 mm, primary profile spacing 900 mm, secondary profile spacing 333 mm

Article no.	Article description	Unit	Quantity
Fixation			
Standard	Safety nail, DN 6 x 35	pcs.	1.3
Suspended brackets			
2016X000	Direct suspended bracket 50/120/200 and	pcs.	1.3
50809000	Tapping screw LN 3.5 x 9.5	pcs.	2.6
or			
20128 / 20151	Vernier hanger/vernier bottom part and	pcs.	1.3
25501000	Vernier safety bolt and	pcs.	1.3
25XXX000	Vernier top part, 200 - 2000 mm, custom lengths on request	pcs.	1.3
Profiles and connectors			
100XX000	CD profile 60/27/0.6 rK, L=XXX mm	m	4.1
10230000	UD profile 28/27/0.6, 3000 mm	m	0.4
20159000	Connector, lengthwise, CD 60/27	pcs.	0.8
20135000	Cross connector, CD 60/27	pcs.	3.3
52130000	Perforated panel screw SN 3.5 x 30	pcs.	22

Check ceiling framework for rigidity and evenness (using a straightedge).

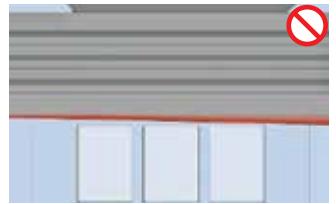
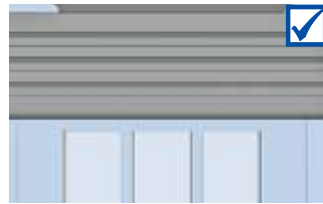

Always mount straight connectors in a staggered manner (see figure) Then check ceiling grid CD sections for centre distances and adjust as necessary.

Measure centre distances accurately!

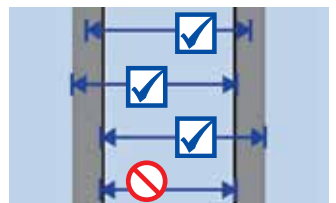
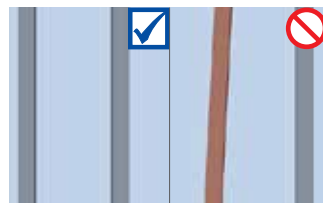

Prior to installation, chamfer edges on visible sides of ceiling panels at 45 degrees using handheld sander. Prime edge area of gypsum core with Vogl Supergrund LF.

The angle must be be 45 degrees.

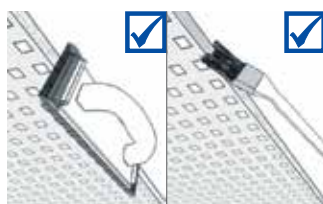

We recommend the following assembly accessories:

Perforated panel screws, including screw bit, Vogl mounting aid, Vogl primer Supergrund LF

Correct handling of ceiling panels:

- Always take into account the load carrying capacity of the building when storing ceiling panels
- Do not store ceiling panels upright, but always flat on panel pallets
- Always carry ceiling panels with short edges upright
- Protect ceiling panels from moisture; relative humidity should be 40 - 80 %
- Avoid major temperature fluctuations
- Do not expose stored ceiling panels to direct sunlight

As viewed from the entrance to the area, choose the panel arrangement with short edge parallel to the windows (main direction of light).



Get the panel to the correct position on the framework using a panel lifter if working alone, or else another worker's help.



Perforation pattern	Centre distance
Straight round perforation 6/18, 8/18, 10/23, 12/25 Offset round perforation 8/12/50, Straight square perforation 8/18, 12/25 Random perforation 8/15/20, 12/20/35	333 mm
Straight round perforation 15/30 Offset round perforation 12/20/66	330 mm

The screws must be put into the panel at right angles, and the countersunk head screwed down to 0.5 mm below the visible surface of the ceiling panel.

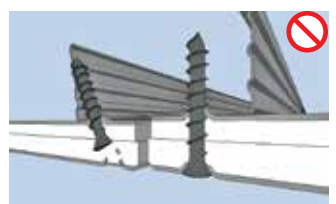
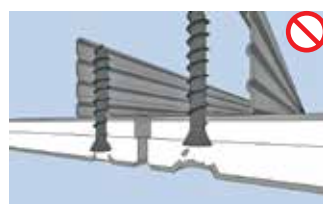
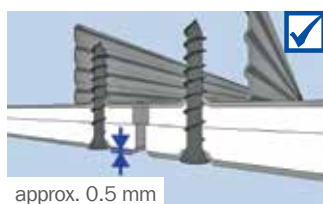

Screws should be spaced maximum 170 mm from fixing point to fixing point. The distance between the screw and the panel edge shall not exceed 26 mm. Avoid damaging acoustic design panels by countersunk heads.

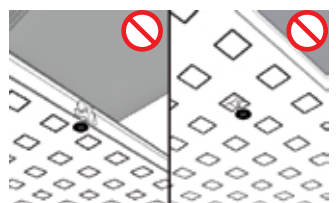
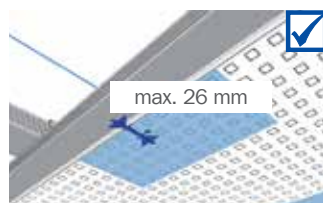
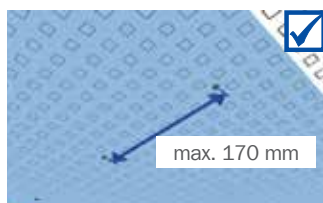

First, screw the ceiling panel to the framework in the centre of the panel, then lower the panel lifter and fix a screw in the centre of each short edge before finally screwing down long edges.

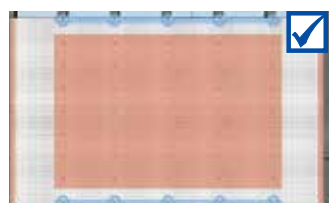

Take note of panel labelling (stamp) and mount in the direction of reading (all stamps should point in the same direction).



Use the CD profile or the straight-edge as an end stop. Position the next panel by sliding it to the first alongside the CD profile/straight-edge and fix in place.

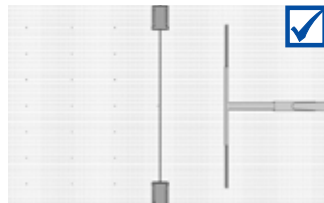

General site conditions/Manufacturer's instructions:

- Take the movement joints of the building structure into account
- Plan to include expansion joints after approx. every 10 m or approx. 100 m²
- Cardboard layer must not be penetrated by screws, but merely displaced downwards
- Working temperature should be at least +10 °C and job site temperature not below +5 °C
- Place any damping (mineral wool layer) directly onto the ceiling panels
- Carry out any additional work on ceiling (access openings, lighting recesses, etc.) immediately after installing ceiling panels and always before finishing joints

Fix screws in panel joint area using alternating pairs across panels ("zig-zag" principle), starting left or right next to the screw which has already been fixed. This will create flush joint areas.

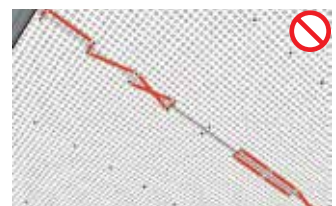
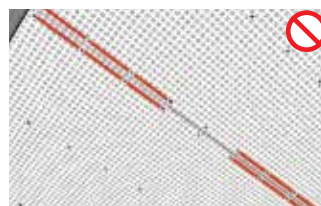
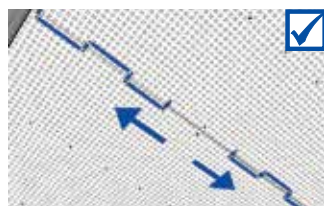

Install ceiling panels first lengthways, then crossways, resulting in a cross arrangement on the ceiling. Cover remaining areas in same manner, working from centre of room outwards.

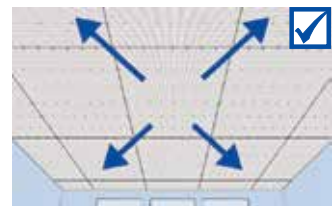

Install rest of ceiling panels, always working with two mounting aids (except in case of random perforation) and heeding proper seating of mounting aids. Install panels exclusively in the "cross joint" system and always check optical appearance of perforation (straight and diagonal).

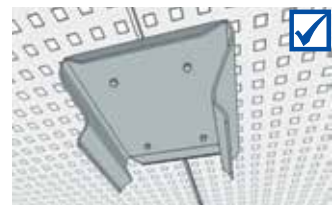

After all panels have been installed, recheck that all joints are level and adjust, if necessary, using a screwdriver. Do another visual check of the perforation pattern, and finally use a straight-edge to check entire ceiling.

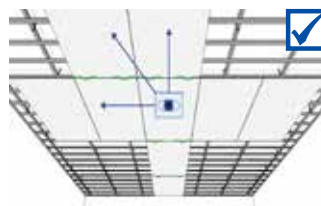
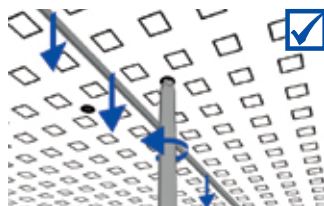

Place any damping layer directly onto back of ceiling panels.

Never screw into the UD28 profile when mounting panels at the ceiling perimeter .

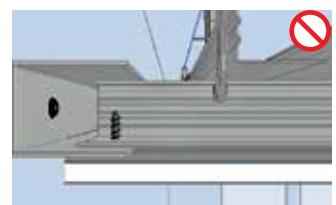
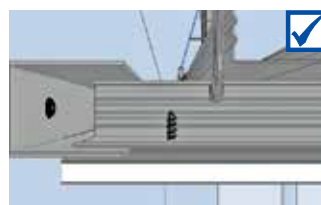
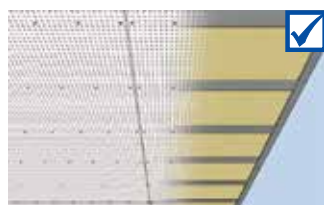

Provide for an expansion joint of 5 to 10 mm every 10 linear metres/100 m².

The additional board strip above the joint must be screwed down on one side only.

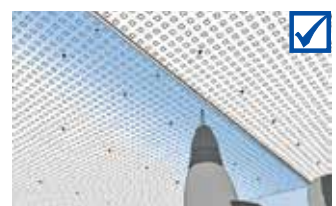
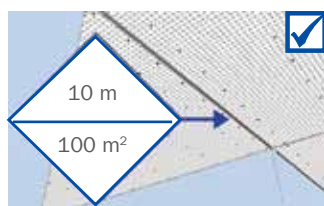

Important! All work that could result in damage to the ceiling surface must be completed before commencing jointing.

Check ceiling, adjust any height discrepancies in joint area with a screw driver.

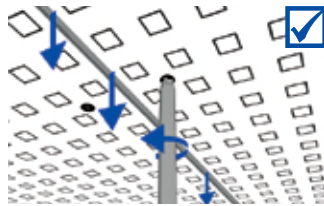

Mix joint compound in a clean pail according to manufacturer's instructions.



General site conditions/Manufacturer's instructions:

- Working temperature should be at least +10 °C and job site temperature not below +5 °C
- Avoid sudden heating and cooling of rooms
- Relative humidity: 40 - 80 %
- Self-levelling, cement or asphalt screeds must be fully dried – make sure there is no residual moisture

Load cartridge and fill joints generously holding cartridge as upright as possible to ensure complete filling of joints.



To achieve high joint strength, make sure a "mushroom" forms between the two panels (see figure).

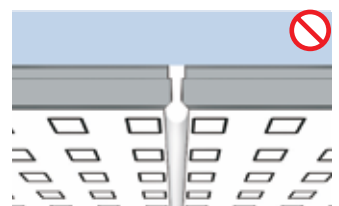
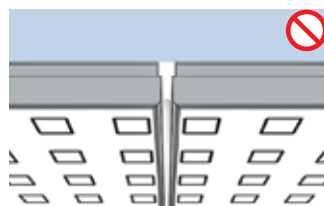
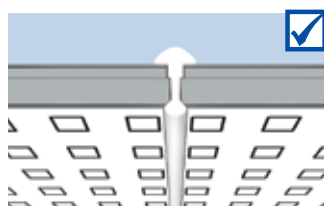

After joint compound has started to cure, and before it has hardened completely, remove any protruding material working in direction of joint.

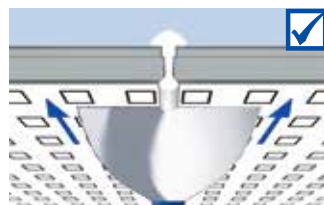
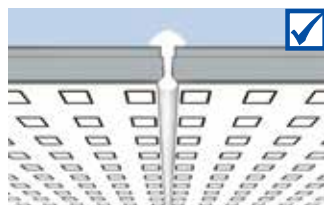

Then refill joints and screw heads with joint or finishing material, having covered perforation adjacent to joint with masking tape beforehand.

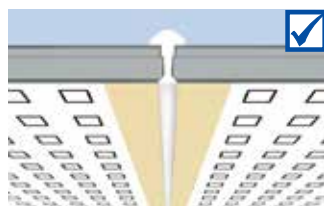

Surface treatment by painters (in accordance with ATV (General technical specifications in construction contracts) DIN 18363, Painting and Coating Work)

- Only apply coating by roller; spray application is not permitted!
- Prior to application of paint coat, a primer should generally be applied in accordance with manufacturer's specifications
- The manufacturer's recommended drying times for both primer and finishing coat must be strictly adhered to
- Alkaline coatings are unsuitable for plasterboards
- 3 coats of paint must be applied (1 prime coat + 2 finishing coats), and recommended drying times adhered to
- Always consult system manufacturer's technical data sheets for primers and finishing coats

Any holes closed with joint compound can be re-opened using a perforation wheel.



After joint compound has completely cured, use a handheld sander to smooth the area.

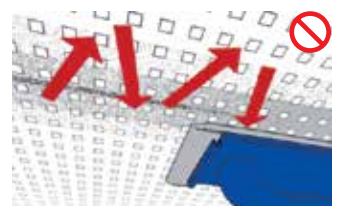
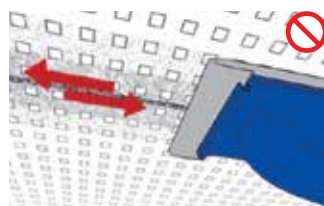
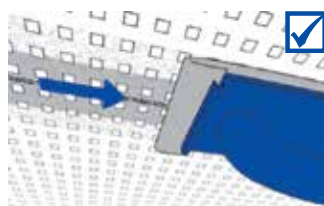

Acoustic design panels
(with air purification effect) – Compound Seam System

Suspended ceiling structure, one side clad with Vogl acoustic design panels backed with sound absorbing fleece, mounted to a rigid ceiling framework of galvanised metal profiles, hung with flush and horizontally aligned suspended brackets and installed using fixing materials approved by the building authorities, installation in accordance with manufacturer's instructions, including all connection and jointing work as well as connection and fixing materials.

System structure

Framework in accordance with DIN 18181:2007-02

Profiles:

Pressure-resistant design made from galvanised sheet steel profiles CD 60/27 as primary and secondary profiles in accordance with EN 14195

Suspended brackets:

- Suspend with vernier systems (top part, vernier hanger),*
- Suspend with vernier systems (top / bottom part),*
- Suspend with direct suspended brackets, *
- Use fixing materials approved by the relevant building authorities.

Connection:

For primary-secondary profile connection with cross connectors, use suspended brackets and cross connectors in accordance with EN 13964,

suspended bracket centre distance: max. 900 mm,
primary profile centre distance: max. 1100 mm,
secondary profile centre distance: 330/333 mm.*

Covering:

Vogl acoustic design panels as perforated ceiling panels in accordance with EN 14190, with air purification effect, one layer 12.5 mm, laid with mounting aid and fixed to the framework using perforated panel screws SN 30, with screw spacing max. 170 mm.

Perforation pattern/perforated area/mass per unit area:

- 6/18 round/8.7 %/9.1 kg/m²*
- 8/18 round/15.5 %/8.5 kg/m²*
- 10/23 round/14.8 %/8.5 kg/m²*
- 12/25 round/18.1 %/8.2 kg/m²*
- 15/30 round/19.6 %/8.0 kg/m²*
- 8/12/50 round/13.1 %/8.7 kg/m²*
- 12/20/66 round/19.6 %/8.0 kg/m²*
- 8/18 square/19.8 %/8.0 kg/m²*
- 12/25 square/23.0 %/7.7 kg/m²*
- 8/15/20 round/9.5 %/9.1 kg/m²*
- 12/20/35 round/11.0 %/8.9 kg/m²*

Distributed load:

- Less than or equal to 0.15 kN/m²*
- Less than or equal to 0.30 kN/m²*

Fleece backing:

Panels backed with sound absorbing fleece as:

- Acoustic fleece, black, *
- Acoustic fleece, white, *

Joint finishing / filling:

Fill screw heads flush with the surface. Carry out joint finishing using the compound seam system in accordance with manufacturer's instructions. Use joint compound as per EN 13963.

Subbase:

Suspension height: h = mm
Installation height: h = mm
Room height: h = mm
Insulation thickness: th = mm

Complete system: Vogl Deckensysteme, or equivalent

* Delete as applicable



VOGL System Training

Our know-how for your
result reliability



Topic:

Installation of acoustic design ceilings – various joint systems

Description

For the installation of different acoustic panel systems, there are also fundamental differences in the finishing of joints. In addition to theoretical fundamentals, our system training offers mainly practical guidelines for the installation work on site. Another topic of the Vogl System Training, beside suspension and connection with various components, is how to solve problems (expansion joints, integrated ceiling elements and wall connections).

Topics

- The variety of joint types and panel systems (including VoglFuge, Compound Seam, GSG4 Joint)
- Panel arrangement and sensible space division for the installation
- Proper joint finishing in the various systems
- Frequent wall connections and how to execute them properly
- Expansion joints in the ceiling area/ regulations and recommendations
- Integrated ceiling components – fundamentals and problems
- Various types of frieze and how to execute them
- How to avoid typical processing errors in the installation work mentioned

Targets

After completion of the seminar, the system training participants shall

- Understand and be able to apply the current standards and regulations
- Recognise and avoid the typical installation errors
- Be able to avoid any problems that may be caused by coating through subsequent trades

Target group

This system training is equally suited for site and project managers as well as for drywall installers and interior construction workers. Also, technically adept employees in sales or from the building material dealers' can extend their knowledge about the proper installation of ceiling structures.

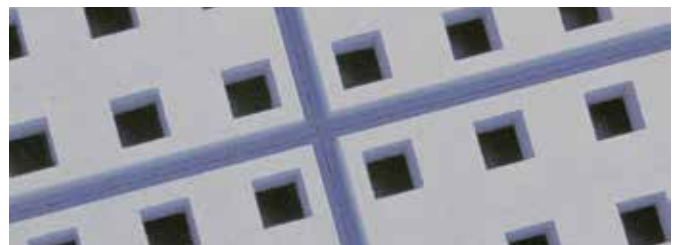

A registration form is available on page 176. You have any questions in advance? We are glad to assist you! Phone: 09104-825-100

Registration is possible by e-mailing sauchella@vogl-deckensysteme.de directly or by fax to 09104/825-280. You can also find all information on training under www.vogl-ceilingssystems.com

Ball-impact Resistant Ceiling



Full Score
*for Acoustics and Ball-
impact Resistance*

Realising perfect gym hall ceilings
with the VoglFuge® system

with air purification
effect as standard

Full score for your ceiling

In sports facilities and multi-purpose halls, ceiling systems not only require acoustic effectiveness, but also special stability. Particularly in highly frequented areas, acoustic ceilings serve as sound absorbers and offer a pleasant atmosphere both for sports and for cultural and music events.

Ideal conditions for using our VoglFuge® system which allows ball-impact resistant acoustic design ceilings to be realised quickly, economically and with reliable results.

Advantages of the VoglFuge® system:

The unique joint technology offers ultimate safety in installation and result also for the ball-impact resistant ceiling structure:

- Different panel variations in 12.5 mm or 15.0 mm thickness
- Ball-impact resistance in compliance with DIN 18032-3 and DIN EN 13964 Appendix D
- Quick mounting of panels – edge to edge
- Maximum crack resistance
- Quickest possible joint finishing with our unique VoglFuge® strip
- Significant time saving due to quick installation and drying times
- Always complete with the VoglFuge® System Kit
- Including perforated panel screws SN 3.5 x 30 mm

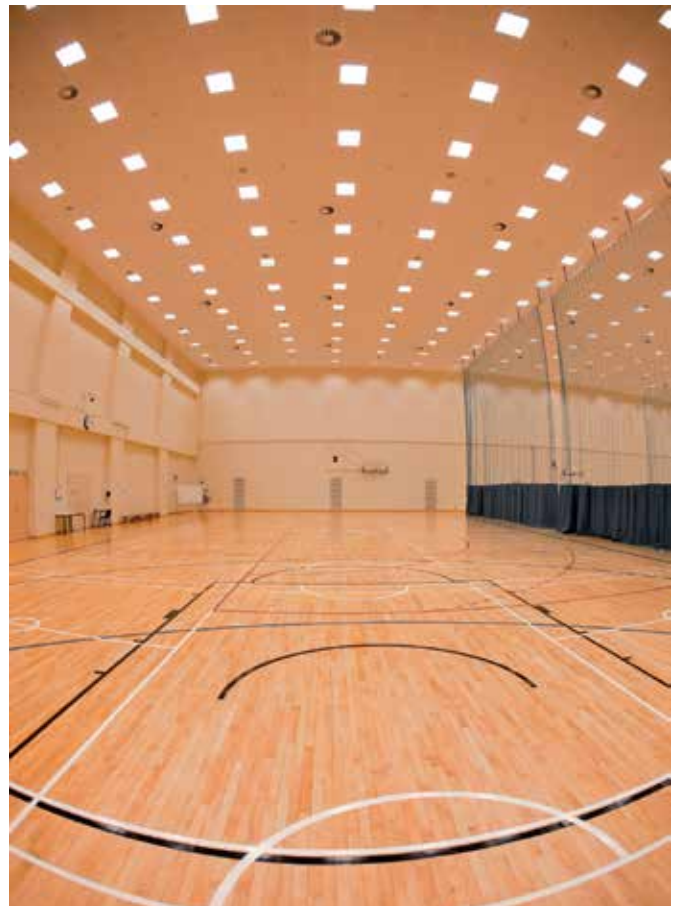

The VoglFuge® System Kit includes the required material, tools and a detailed assembly instruction to ensure top quality workmanship and reliable results.

The right tools at the right time in exactly the right place

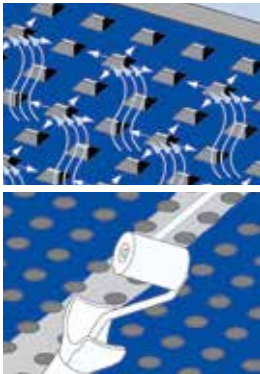

Our acoustic design panels are perforated ceiling panels with high acoustic performance and air purification effect (adsorption).

Other available options: Acoustic design panels with non-perforated edges, block perforation, applications, manufacture in accordance with customer designs and ceiling plans.

Standards: EN 14190 "Gypsum plasterboard products from reprocessing"
Material class: A2-s1, d0 (non-combustible) according to EN 13501
Long edge: SK (sharp-edged)
Short edge: SK (sharp-edged)

with air purification
 effect as standard

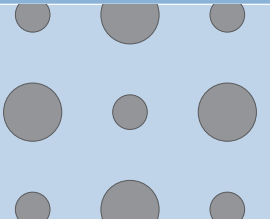
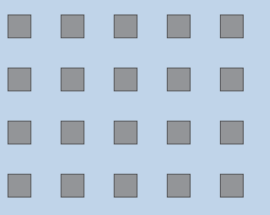
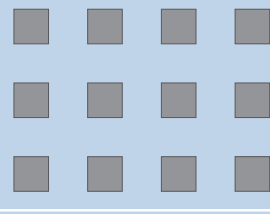
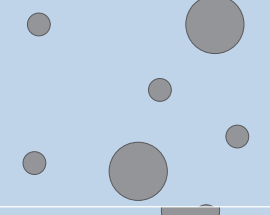
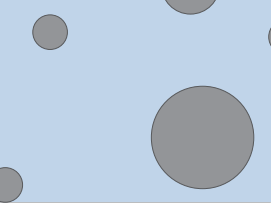
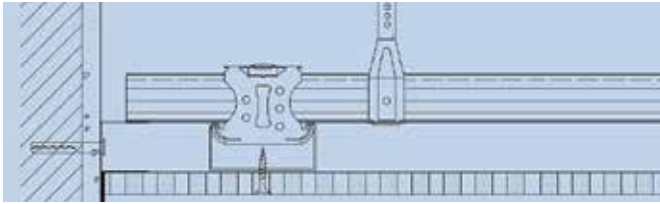

Illustration	Item number	Description	Details	m ² /pallet Pcs./pallet
	7061101110	Acoustic design panel VF 6/18R Acoustic fleece, black	1188 x 1998 x 12.5 mm	59.3 m ²
	7061101120	Acoustic design panel VF 6/18R Acoustic fleece, white	Perforated area: 8.7 % Mass: 9.1 kg/m ²	25 pcs.
	7062101110	Acoustic design panel VF 6/18R Acoustic fleece, black	1188 x 1998 x 15.0 mm	59.3 m ²
	7062101120	Acoustic design panel VF 6/18R Acoustic fleece, white	Perforated area: 8.7 % Mass: 11.4 kg/m ²	25 pcs.
	7061102110	Acoustic design panel VF 8/18R Acoustic fleece, black	1188 x 1998 x 12.5 mm	59.3 m ²
	7061102120	Acoustic design panel VF 8/18R Acoustic fleece, white	Perforated area: 15.5 % Mass: 8.5 kg/m ²	25 pcs.
	7062102110	Acoustic design panel VF 8/18R Acoustic fleece, black	1188 x 1998 x 15.0 mm	59.3 m ²
	7062102120	Acoustic design panel VF 8/18R Acoustic fleece, white	Perforated area: 15.5 % Mass: 10.5 kg/m ²	25 pcs.
	7061103110	Acoustic design panel VF 10/23R Acoustic fleece, black	1196 x 2001 x 12.5 mm	59.8 m ²
	7061103120	Acoustic design panel VF 10/23R Acoustic fleece, white	Perforated area: 14.8 % Mass: 8.5 kg/m ²	25 pcs.
	7062103110	Acoustic design panel VF 10/23R Acoustic fleece, black	1196 x 2001 x 15.0 mm	59.8 m ²
	7062103120	Acoustic design panel VF 10/23R Acoustic fleece, white	Perforated area: 14.8 % Mass: 10.6 kg/m ²	25 pcs.
	7061104110	Acoustic design panel VF 12/25R Acoustic fleece, black	1196 x 2001 x 12.5 mm	60.0 m ²
	7061104120	Acoustic design panel VF 12/25R Acoustic fleece, white	Perforated area: 18.1 % Mass: 8.2 kg/m ²	25 pcs.
	7062104110	Acoustic design panel VF 12/25R Acoustic fleece, black	1200 x 2000 x 15.0 mm	60.0 m ²
	7062104120	Acoustic design panel VF 12/25R Acoustic fleece, white	Perforated area: 18.1 % Mass: 10.2 kg/m ²	25 pcs.
	7061105110	Acoustic design panel VF 15/30R Acoustic fleece, black	1200 x 1980 x 12.5 mm	59.4 m ²
	7061105120	Acoustic design panel VF 15/30R Acoustic fleece, white	Perforated area: 19.6 % Mass: 8.0 kg/m ²	25 pcs.
	7062105110	Acoustic design panel VF 15/30R Acoustic fleece, black	1200 x 1980 x 15.0 mm	59.4 m ²
	7062105120	Acoustic design panel VF 15/30R Acoustic fleece, white	Perforated area: 19.6 % Mass: 10.5 kg/m ²	25 pcs.
	7061106110	Acoustic design panel VF 8/12/50R Acoustic fleece, black	1200 x 2000 x 12.5 mm	60.0 m ²
	7061106120	Acoustic design panel VF 8/12/50R Acoustic fleece, white	Perforated area: 13.1 % Mass: 8.7 kg/m ²	25 pcs.
	7062106110	Acoustic design panel VF 8/12/50R Acoustic fleece, black	1200 x 2000 x 15.0 mm	60.0 m ²
	7062106120	Acoustic design panel VF 8/12/50R Acoustic fleece, white	Perforated area: 13.1 % Mass: 10.9 kg/m ²	25 pcs.

Illustration	Item number	Description	Details	m ² /pallet Pcs./pallet
	7061107110	Acoustic design panel VF 12/20/66R Acoustic fleece, black	1188 x 1980 x 12.5 mm Perforated area: 19.6 % Mass: 8.0 kg/m ²	58.8 m ² 25 pcs.
	7061107120	Acoustic design panel VF 12/20/66R Acoustic fleece, white		
	7062107110	Acoustic design panel VF 12/20/66R Acoustic fleece, black	1188 x 1980 x 15.0 mm Perforated area: 19.6 % Mass: 10.0 kg/m ²	58.8 m ² 25 pcs.
	7062107120	Acoustic design panel VF 12/20/66R Acoustic fleece, white		
	7061108110	Acoustic design panel VF 8/18Q Acoustic fleece, black	1188 x 1980 x 12.5 mm Perforated area: 19.8 % Mass: 8.0 kg/m ²	59.3 m ² 25 pcs.
	7061108120	Acoustic design panel VF 8/18Q Acoustic fleece, white		
	7062108110	Acoustic design panel VF 8/18Q Acoustic fleece, black	1188 x 1980 x 15.0 mm Perforated area: 19.8 % Mass: 10.0 kg/m ²	59.38 m ² 25 pcs.
	7062108120	Acoustic design panel VF 8/18Q Acoustic fleece, white		
	7061104110	Acoustic design panel VF 12/25Q Acoustic fleece, black	1200 x 2000 x 12.5 mm Perforated area: 23.0 % Mass: 7.7 kg/m ²	60.0 m ² 25 pcs.
	7061104120	Acoustic design panel VF 12/25Q Acoustic fleece, white		
	7062104110	Acoustic design panel VF 12/25Q Acoustic fleece, black	1200 x 2000 x 15.0 mm Perforated area: 23.0 % Mass: 9.6 kg/m ²	60.0 m ² 25 pcs.
	7062104120	Acoustic design panel VF 12/25Q Acoustic fleece, white		
	7061110110	Acoustic design panel VF 8/15/20R Acoustic fleece, black	1200 x 1980 x 12.5 mm Perforated area: 9.5 % Mass: 9.1 kg/m ²	60.0 m ² * 25 pcs.
	7061110120	Acoustic design panel VF 8/15/20R Acoustic fleece, white		
	7062110110	Acoustic design panel VF 8/15/20R Acoustic fleece, black	1200 x 1980 x 15.0 mm Perforated area: 9.5 % Mass: 11.3 kg/m ²	60.0 m ² * 25 pcs.
	7062110120	Acoustic design panel VF 8/15/20R Acoustic fleece, white		
	7061111110	Acoustic design panel VF 12/20/35R Acoustic fleece, black	1200 x 2000 x 12.5 mm Perforated area: 11.0 % Mass: 8.9 kg/m ²	60.0 m ² * 25 pcs.
	7061111120	Acoustic design panel VF 12/20/35R Acoustic fleece, white		
	7062111110	Acoustic design panel VF 12/20/35R Acoustic fleece, black	1200 x 2000 x 15.0 mm Perforated area: 11.0 % Mass: 11.1 kg/m ²	60.0 m ² * 25 pcs.
	7062111120	Acoustic design panel VF 12/20/35R Acoustic fleece, white		



*Note: Despite being perforated irregularly, random perforation panels still yield a certain linear layout as the abutting panel edges must be non-perforated in any case. This is unavoidable and independent of the workmanship of the specialist contractor.



Wall connection:

For filled wall connections, or wall connections filled from below, a double layer fleece strip is used to separate the acoustic ceiling from the wall.

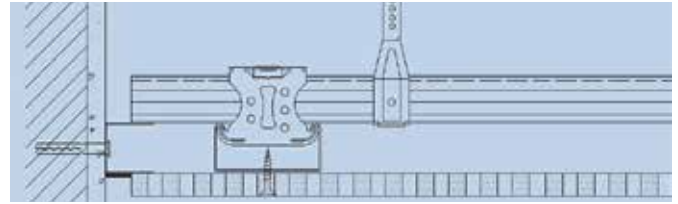

Wall connection – shadow gap:

For wall connections with a shadow gap, the panel is only installed up to the UD profile as this may be covered with a strip of adhesive double layer fleece in order to colour the shadow gap.

Please contact us if you require additional technical details on possible wall connections.

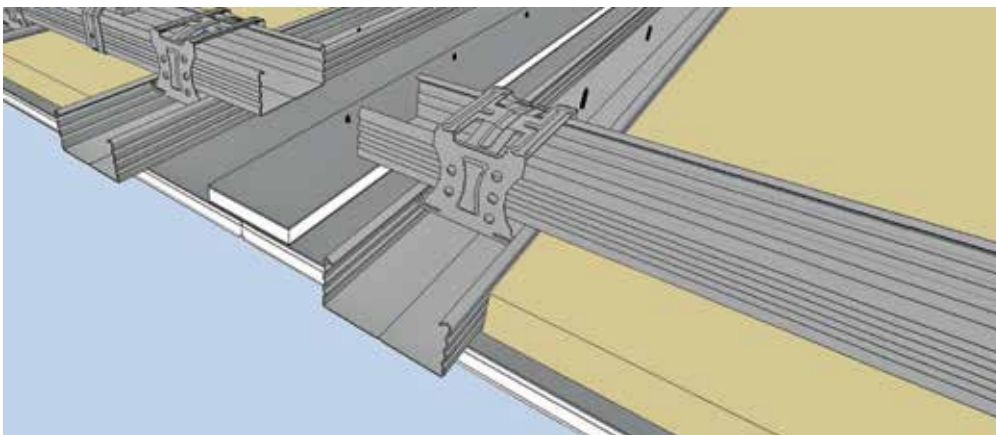

Expansion joints:

To prevent cracking in the ceiling surface, expansion joints have to be provided every 10 linear metres/100 m² of the ceiling area.

The framework must be completely severed (see illustration) and the panel strips above the joint fixed to one side of the ceiling structure only.

Tip: the panel strip may be covered with adhesive double layer fleece on the visible side if colouring the expansion joint in either black or white is desired.

Material required per m² based on a ceiling of 100 m² (10 m x 10 m, not considering loss or waste, approximate values):

Metal framework, suspended bracket centre distance 1000 mm, primary profile spacing 900 mm, secondary profile spacing 333 mm

Article no.	Article description	Unit	Quantity
Fixation			
Standard	Safety nail, DN 6 x 35	pcs.	1.3
Suspended brackets			
2016X000	Direct suspended bracket 50/120/200 and	pcs.	1.3
50809000	Tapping screw LN 3.5 x 9.5	pcs.	2.6
or			
20128 / 20151	Vernier hanger/vernier bottom part and	pcs.	1.3
25501000	Vernier safety bolt and	pcs.	1.3
25XXX000	Vernier top part, 200 - 2,000 mm, custom lengths on request	pcs.	1.3
Profiles and connectors			
100XX000	CD profile 60/27/0.6 rK, L=XXX mm	m	4.1
10230000	UD profile 28/27/0.6, 3000 mm	m	0.4
20159000	Connector, lengthwise, CD 60/27	pcs.	0.8
20135000	Cross connector, CD 60/27	pcs.	3.3
52130000	Perforated panel screw SN 3.5 x 30	pcs.	22

Note: In case of shorter secondary profile centres, the quantities consumed shall be increased accordingly.

The primary profiles are rigidly hung from the structural soffit with suspended brackets using fixing materials approved by the relevant building authorities.

The centre distance and the number of suspended brackets as well as the fixing material are subject to site requirements and EN 13964/DIN 18181. The CD 60/27 secondary profiles are attached to the primary profiles CD 60/27 using cross connectors.

CD 60/27 are extended using straight connectors. For primary grid profiles, always ensure that the joint is close to a suspended bracket (max. 100 mm). Joints should generally be staggered.

The plasterboards should be installed in accordance with EN 13964/DIN 18181 and the manufacturer's guidelines.

Additional items such as lighting, ventilation, sprinkler systems etc. must be individually suspended.

Any changes in the framework owing to integrated ceiling components must be considered.

Block perforations and block slots require different secondary profile centre distances which are shown in our tables on page 111.

Framework, ball-impact resistant ceiling									
Technical data	Unit	Perforated panel ceiling							
Panel thickness	mm	12.5							
Distributed load	kN/m ²	≤ 0.15				≤ 0.30			
Centre distance of suspended bracket A	mm	1150	1050	1000	950	900	900	750	
Centre distance of primary profiles X	mm	600	800	900	1000	1100	600	1000	
Centre distance of secondary profiles Y	mm	see table below							

Article	Unit	Centre distance of secondary profiles Y	
see table on page 107			

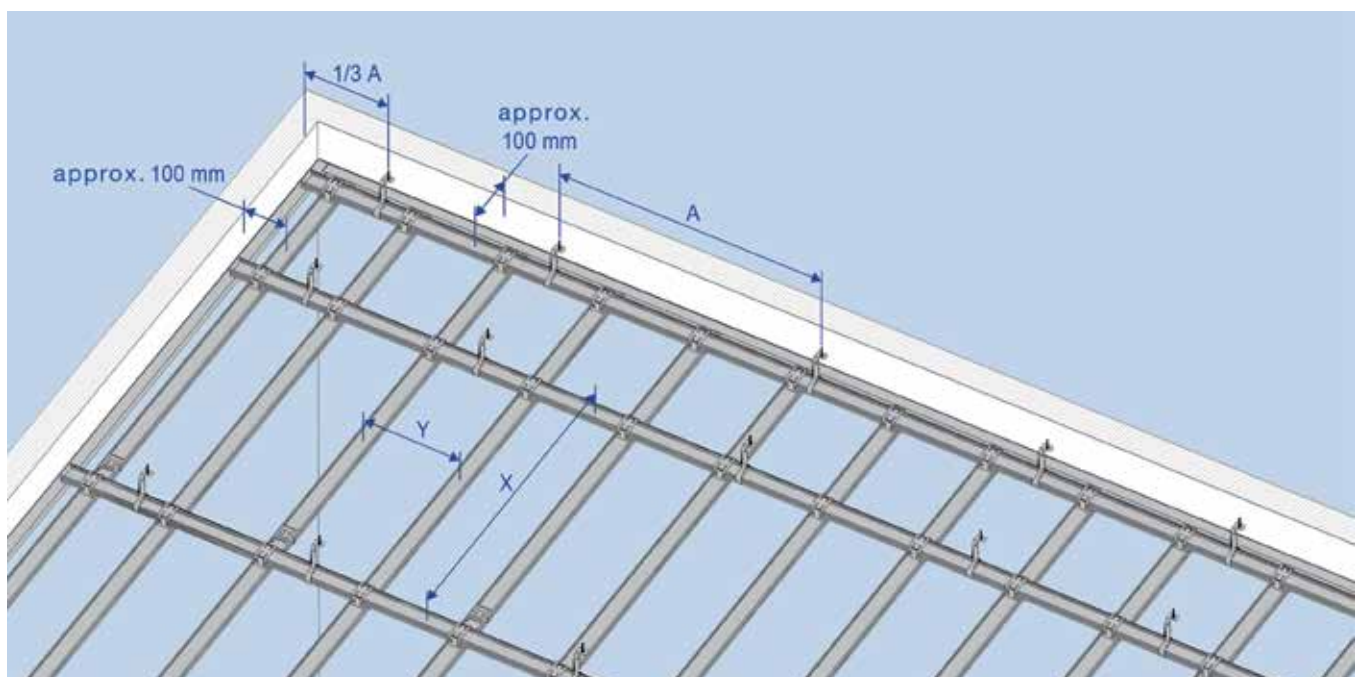

Our ceiling system was tested in accordance with DIN 18032-3: 1997-04 "Gyms, halls for gymnastics and games and multi-purpose use, testing of ball impact resistance" as well as EN 13964: 2007-02, Appendix D "Suspended ceilings: requirements and testing methods, impact resistance".

The tested ceiling panels withstood the stress without any damage. The systems are thus tested as "ball-impact resistant" in compliance with DIN 18032-3 for the application area of "ceiling" as well as with EN 13964 Appendix D as "Class 1A".

Our acoustic design ceilings were tested by an accredited testing institute on the basis of the aforementioned standards. The testing consisted in the ceiling panels being pelted with a handball with a total of 36 shots at various angles of impact on the suspended ceiling.

This applies to the following acoustic design ceiling panels in conjunction with the secondary profile centres indicated:

Acoustic design panel. th = 12.5 mm		
Article	Perforated area	Centre distance of secondary profiles Y (mm)
6/18 round	8.7 %	250
8/18 round	15.5 %	250
10/23 round	14.8 %	250
12/25 round	18.1 %	200
15/30 round	19.6 %	200
8/12/50 round	13.1 %	250
12/20/66 round	19.6 %	200
8/18 square	19.8 %	200
12/25 square	23.0 %	200
8/15/20 round	9.5 %	250
12/20/35 round	11.0 %	250

Acoustic design panel. th = 15.0 mm		
Article	Perforated area	Centre distance of secondary profiles Y (mm)
6/18 round	8.7 %	333
8/18 round	15.5 %	333
10/23 round	14.8 %	333
12/25 round	18.1 %	333
15/30 round	19.6 %	330
8/12/50 round	13.1 %	333
12/20/66 round	19.6 %	330
8/18 square	19.8 %	333
12/25 square	23.0 %	333
8/15/20 round	9.5 %	333
12/20/35 round	11.0 %	333



**Acoustic design panels for "ball-impact resistant ceiling"
(with air purification effect) – VoglFuge® system**

Suspended ceiling structure, one side clad with Vogl acoustic design panels, backed with sound absorbing fleece, mounted to a rigid ceiling framework of galvanised metal profiles, hung with flush and horizontally aligned suspended brackets and installed using fixing materials approved by the building authorities, installation in accordance with manufacturer's instructions, including all connection and jointing work as well as connection and fixing materials. Designed as "ball-impact resistant ceiling".

System structure

Framework in accordance with DIN 18181:2007-02

Profiles:

Pressure-resistant design made from galvanised sheet steel profiles CD 60/27 as primary and secondary profiles in accordance with EN 14195

Suspended brackets:

- Rigid suspension in vernier system
- Use fixing materials approved by the relevant building authorities.

Connection:

For primary-secondary profile connection with cross connectors, use suspended brackets and cross connectors in accordance with EN 13964,

suspended bracket centre distance: max. 900 mm,
primary profile centre distance: max. 1,100 mm,
secondary profile centre distance: 200/250/330/333 mm.*

Covering:

Vogl acoustic design panels are perforated ceiling panels in accordance with EN 14190, with air purification effect, one layer 12.5 mm*/15.0 mm*, laid edge to edge and fixed to the framework using Vogl perforated panel screws SN 30, with screw spacing max. 170 mm.

Perforation pattern/perforated area/mass per unit area:

- 6/18 round/8.7 %/9.1 kg/m² *
- 8/18 round/15.5 %/8.5 kg/m² *
- 10/23 round/14.8 %/8.5 kg/m² *
- 12/25 round/18.1 %/8.2 kg/m² *
- 15/30 round/19.6 %/8.0 kg/m² *
- 8/12/50 round/13.1 %/8.7 kg/m² *
- 12/20/66 round/19.6 %/8.0 kg/m² *
- 8/18 square/19.8 %/8.0 kg/m² *
- 12/25 square/23.0 %/7.7 kg/m² *
- 8/15/20 round/9.5 %/9.1 kg/m² *
- 12/20/35 round/11.0 %/8.9 kg/m² *

Ball impact resistance:

Design as "ball-impact resistant ceiling" tested: "ball-impact resistant" in compliance with DIN 18032-3 for the application area of "ceiling"; "impact resistance class 1A" as per EN 13964 Appendix D

Distributed load:

- Less than or equal to 0.15 kN/m² *
- Less than or equal to 0.30 kN/m² *

Fleece backing:

Panels backed with sound absorbing fleece as:

- Acoustic fleece, black,*
- Acoustic fleece, white,*

Joint finishing/filling:

Fill screw heads using Vogl screw head and repair filler flush with the surface. Carry out joint finishing using the VoglFuge® system in accordance with manufacturer's instructions.

Subbase:

Suspension height: h = mm
Installation height: h = mm
Room height: h = mm
Insulation thickness: th = mm

Complete system: Vogl Deckensysteme, or equivalent

* Delete as applicable



Basic, Excellent, Premium Systems

Ceiling Tiles



Perfect for Ceilings
with Lots Behind them

Aesthetics and accessibility in perfect harmony

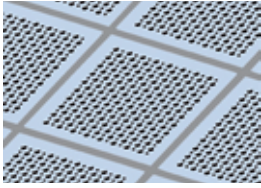

Vogl Ceiling Tiles are accessible, perforated ceiling panels with high acoustic performance for installation into T-profile systems.

The black acoustic fleece lining on the back (other colours on request) satisfies the highest demands on sound absorption.

Vogl Ceiling Tiles come with a pure white finishing coat (similar to RAL 9010).

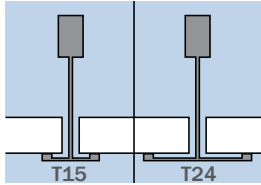

Installation system: Basic (T15/T24) visible installation
Standards: EN 14190 "Gypsum plasterboard products from reprocessing"
Material class: A2-s1, d0 (non-combustible) according to EN 13501
Long edge: SK (sharp-edged)
Short edge: SK (sharp-edged)



Illustration	Item number	Description	Details	Piece/PU PU/pallet
	7301100000	GP-K Basic 600 T15/T24 smooth	600 x 600 x 12.5 mm	6 pcs. 28 PU
	7301200000	GP-K Basic 625 T15/T24 smooth	625 x 625 x 12.5 mm	
	7301101110	GP-K Basic 600 T15/T24 6/18R AVS Acoustic fleece, black	600 x 600 x 12.5 mm	6 pcs. 28 PU
	7301201110	GP-K Basic 625 T15/T24 6/18R AVS Acoustic fleece, black	625 x 625 x 12.5 mm	
	7301102110	GP-K Basic 600 T15/T24 8/18R AVS Acoustic fleece, black	600 x 600 x 12.5 mm	6 pcs. 28 PU
	7301202110	GP-K Basic 625 T15/T24 8/18R AVS Acoustic fleece, black	625 x 625 x 12.5 mm	
	7301107110	GP-K Basic 600 T15/T24 12/20/66R AVS Acoustic fleece, black	600 x 600 x 12.5 mm	6 pcs. 28 PU
	7301207110	GP-K Basic 625 T15/T24 12/20/66R AVS Acoustic fleece, black	625 x 625 x 12.5 mm	
	7301108110	GP-K Basic 600 T15/T24 8/18Q AVS Acoustic fleece, black	600 x 600 x 12.5 mm	6 pcs. 28 PU
	7301208110	GP-K Basic 625 T15/T24 8/18Q AVS Acoustic fleece, black	625 x 625 x 12.5 mm	
	7301109110	GP-K Basic 600 T15/T24 12/25Q AVS Acoustic fleece, black	600 x 600 x 12.5 mm	6 pcs. 28 PU
	7301209110	GP-K Basic 625 T15/T24 12/25Q AVS Acoustic fleece, black	625 x 625 x 12.5 mm	
	7301112110	GP-K Basic 600 T15/T24 5/82/15.4SL AVS Acoustic fleece, black	600 x 600 x 12.5 mm	6 pcs. 28 PU
	7301212110	GP-K Basic 625 T15/T24 5/82/15.4SL AVS Acoustic fleece, black	625 x 625 x 12.5 mm	
	7301114110	GP-K Basic 600 T15/T24 3.5/9Q AVS Acoustic fleece, black	600 x 600 x 12.5 mm	6 pcs. 28 PU
	7301214110	GP-K Basic 625 T15/T24 3.5/9Q AVS Acoustic fleece, black	625 x 625 x 12.5 mm	

Further perforation patterns/dimensions available on request

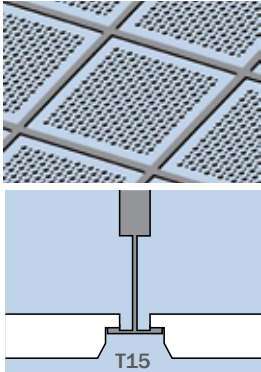

Vogl Ceiling Tiles are accessible, perforated ceiling panels with high acoustic performance for installation into T-profile systems.

The black acoustic fleece lining on the back (other colours on request) satisfies the highest demands on sound absorption.

Vogl Ceiling Tiles come with a pure white finishing coat (similar to RAL 9010).

Installation system: Excellent (T15) partially concealed installation
Standards: EN 14190 "Gypsum plasterboard products from reprocessing"
Material class: A2-s1, d0 (non-combustible) according to EN 13501
Long edge: FK T15 (chamfered), type Excellent
Short edge: FK T15 (chamfered), type Excellent



Illustration	Item number	Description	Details	Piece/PU PU/pallet
	7311300000	GP-K Excellent 600 T15 smooth	600 x 600 x 12.5 mm	6 pcs. 28 PU
	7311500000	GP-K Excellent 625 T15 smooth	625 x 625 x 12.5 mm	
	7311301110	GP-K Excellent 600 T15 6/18R AVS Acoustic fleece, black	600 x 600 x 12.5 mm	6 pcs. 28 PU
	7311501110	GP-K Excellent 625 T15 6/18R AVS Acoustic fleece, black	625 x 625 x 12.5 mm	
	7311302110	GP-K Excellent 600 T15 8/18R AVS Acoustic fleece, black	600 x 600 x 12.5 mm	6 pcs. 28 PU
	7311502110	GP-K Excellent 625 T15 8/18R AVS Acoustic fleece, black	625 x 625 x 12.5 mm	
	7311307110	GP-K Excellent 600 T15 12/20/66R AVS Acoustic fleece, black	600 x 600 x 12.5 mm	6 pcs. 28 PU
	7311507110	GP-K Excellent 625 T15 12/20/66R AVS Acoustic fleece, black	625 x 625 x 12.5 mm	
	7311308110	GP-K Excellent 600 T15 8/18Q AVS Acoustic fleece, black	600 x 600 x 12.5 mm	6 pcs. 28 PU
	7311508110	GP-K Excellent 625 T15 8/18Q AVS Acoustic fleece, black	625 x 625 x 12.5 mm	
	7311309110	GP-K Excellent 600 T15 12/25Q AVS Acoustic fleece, black	600 x 600 x 12.5 mm	6 pcs. 28 PU
	7311509110	GP-K Excellent 625 T15 12/25Q AVS Acoustic fleece, black	625 x 625 x 12.5 mm	
	7311312110	GP-K Excellent 600 T15 5/82/15.4SL AVS Acoustic fleece, black	600 x 600 x 12.5 mm	6 pcs. 28 PU
	7311512110	GP-K Excellent 625 T15 5/82/15.4SL AVS Acoustic fleece, black	625 x 625 x 12.5 mm	
	7311314110	GP-K Excellent 600 T15 3.5/9Q AVS Acoustic fleece, black	600 x 600 x 12.5 mm	6 pcs. 28 PU
	7311514110	GP-K Excellent 625 T15 3.5/9Q AVS Acoustic fleece, black	625 x 625 x 12.5 mm	

Further perforation patterns/dimensions available on request

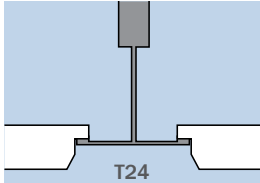
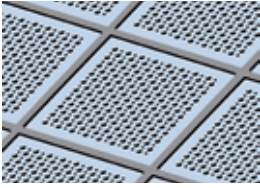

Vogl Ceiling Tiles are accessible, perforated ceiling panels with high acoustic performance for installation into T-profile systems.

The black acoustic fleece lining on the back (other colours on request) satisfies the highest demands on sound absorption.

Vogl Ceiling Tiles come with a pure white finishing coat (similar to RAL 9010).

Installation system: Excellent (T24) partially concealed installation
Standards: EN 14190 "Gypsum plasterboard products from reprocessing"
Material class: A2-s1, d0 (non-combustible) according to EN 13501
Long edge: FK T24 (chamfered), type Excellent
Short edge: FK T24 (chamfered), type Excellent



Illustration	Item number	Description	Details	Piece/PU PU/pallet
	7311400000	GP-K Excellent 600 T24 smooth	600 x 600 x 12.5 mm	6 pcs.
	7311600000	GP-K Excellent 600 T24 smooth	625 x 625 x 12.5 mm	28 PU
	7311401110	GP-K Excellent 600 T24 6/18R AVS Acoustic fleece, black	600 x 600 x 12.5 mm	6 pcs.
	7311601110	GP-K Excellent 625 T24 6/18R AVS Acoustic fleece, black	625 x 625 x 12.5 mm	28 PU
	7311402110	GP-K Excellent 600 T24 8/18R AVS Acoustic fleece, black	600 x 600 x 12.5 mm	6 pcs.
	7311602110	GP-K Excellent 625 T24 8/18R AVS Acoustic fleece, black	625 x 625 x 12.5 mm	28 PU
	7311407110	GP-K Excellent 600 T24 12/20/66R AVS Acoustic fleece, black	600 x 600 x 12.5 mm	6 pcs.
	7311607110	GP-K Excellent 625 T24 12/20/66R AVS Acoustic fleece, black	625 x 625 x 12.5 mm	28 PU
	7311408110	GP-K Excellent 600 T24 8/18Q AVS Acoustic fleece, black	600 x 600 x 12.5 mm	6 pcs.
	7311608110	GP-K Excellent 625 T24 8/18Q AVS Acoustic fleece, black	625 x 625 x 12.5 mm	28 PU
	7311409110	GP-K Excellent 600 T24 12/25Q AVS Acoustic fleece, black	600 x 600 x 12.5 mm	6 pcs.
	7311609110	GP-K Excellent 625 T24 12/25Q AVS Acoustic fleece, black	625 x 625 x 12.5 mm	28 PU
	7311412110	GP-K Excellent 600 T24 5/82/15.4SL AVS Acoustic fleece, black	600 x 600 x 12.5 mm	6 pcs.
	7311612110	GP-K Excellent 625 T24 5/82/15.4SL AVS Acoustic fleece, black	625 x 625 x 12.5 mm	28 PU
	7311414110	GP-K Excellent 600 T24 3.5/9Q AVS Acoustic fleece, black	600 x 600 x 12.5 mm	6 pcs.
	7311614110	GP-K Excellent 625 T24 3.5/9Q AVS Acoustic fleece, black	625 x 625 x 12.5 mm	28 PU

Further perforation patterns/dimensions available on request

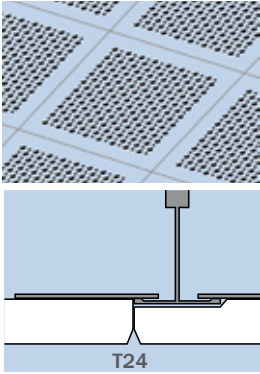

Vogl Ceiling Tiles are accessible, perforated ceiling panels with high acoustic performance for installation into T-profile systems.

The black acoustic fleece lining on the back (other colours on request) satisfies the highest demands on sound absorption.

Vogl Ceiling Tiles come with a pure white finishing coat (similar to RAL 9010).

Installation system: Premium (T24) concealed installation
Standards: EN 14190 "Gypsum plasterboard products from reprocessing" "
Material class: A2-s1, d0 (non-combustible) according to EN 13501
Long edge: FK T24 (chamfered), type Premium
Short edge: FK T24 (chamfered), type Premium



Illustration	Item number	Description	Details	Piece/PU PU/pallet
	7331400000	GP-K Premium 600 T24 smooth	600 x 600 x 12.5 mm	6 pcs. 28 PU
	7331600000	GP-K Premium 625 T24 smooth	625 x 625 x 12.5 mm	
	7331401110	GP-K Premium 600 T24 6/18R AVS Acoustic fleece, black	600 x 600 x 12.5 mm	6 pcs. 28 PU
	7331601110	GP-K Premium 625 T24 6/18R AVS Acoustic fleece, black	625 x 625 x 12.5 mm	
	7331402110	GP-K Premium 600 T24 8/18R AVS Acoustic fleece, black	600 x 600 x 12.5 mm	6 pcs. 28 PU
	7331602110	GP-K Premium 625 T24 8/18R AVS Acoustic fleece, black	625 x 625 x 12.5 mm	
	7331407110	GP-K Premium 600 T24 12/20/66R AVS Acoustic fleece, black	600 x 600 x 12.5 mm	6 pcs. 28 PU
	7331607110	GP-K Premium 625 T24 12/20/66R AVS Acoustic fleece, black	625 x 625 x 12.5 mm	
	7331408110	GP-K Premium 600 T24 8/18Q AVS Acoustic fleece, black	600 x 600 x 12.5 mm	6 pcs. 28 PU
	7331608110	GP-K Premium 625 T24 8/18Q AVS Acoustic fleece, black	625 x 625 x 12.5 mm	
	7331409110	GP-K Premium 600 T24 12/25Q AVS Acoustic fleece, black	600 x 600 x 12.5 mm	6 pcs. 28 PU
	7331609110	GP-K Premium 625 T24 12/25Q AVS Acoustic fleece, black	625 x 625 x 12.5 mm	
	7331412110	GP-K Premium 600 T24 5/82/15.4SL AVS Acoustic fleece, black	600 x 600 x 12.5 mm	6 pcs. 28 PU
	7331612110	GP-K Premium 625 T24 5/82/15.4SL AVS Acoustic fleece, black	625 x 625 x 12.5 mm	
	7331414110	GP-K Premium 600 T24 3.5/9Q AVS Acoustic fleece, black	600 x 600 x 12.5 mm	6 pcs. 28 PU
	7331614110	GP-K Premium 625 T24 3.5/9Q AVS Acoustic fleece, black	625 x 625 x 12.5 mm	

Further perforation patterns/dimensions available on request

Basic T15/T24 ("exposed" grid):

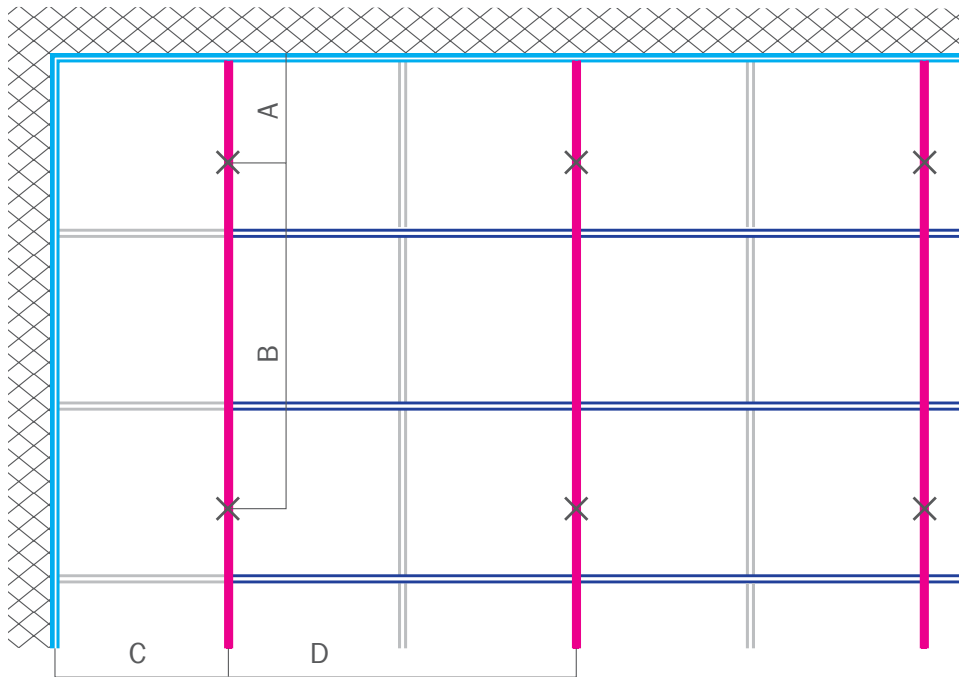

A = max. 400 mm B = max. 1200/1250 mm C = max. 600/625 mm D = 600/1200 mm or 625/1250 mm

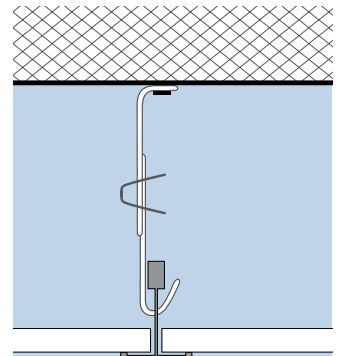

- Wall angle or stepped wall angle
- Secondary profile
- Cross profile "long"
- Cross profile "short"
- Quick hanger (type dependent on suspension height)

Basic T15/T24 ("rebated" grid):

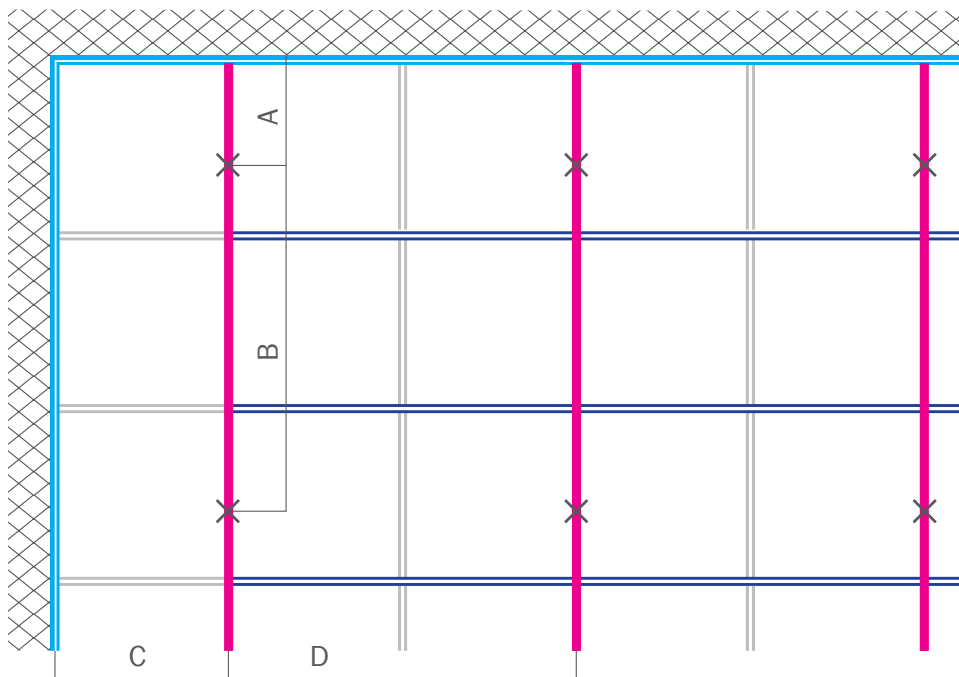

A = max. 400 mm B = max. 1200/1250 mm C = max. 600/625 mm D = 600/1200 mm or 625/1250 mm

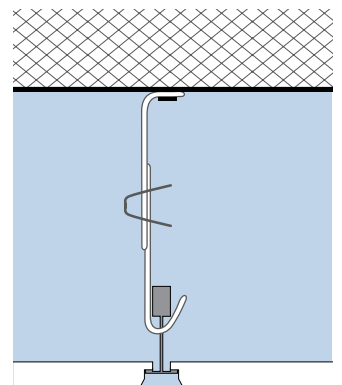

- Wall angle or stepped wall angle
- Secondary profile
- Cross profile "long"
- Cross profile "short"
- Quick hanger (type dependent on suspension height)

Premium T24 ("concealed" grid):

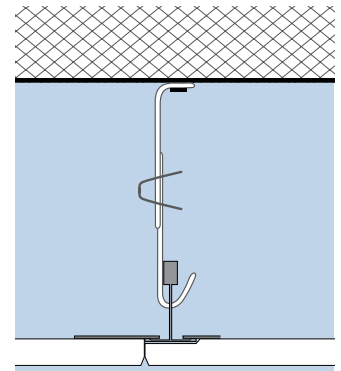
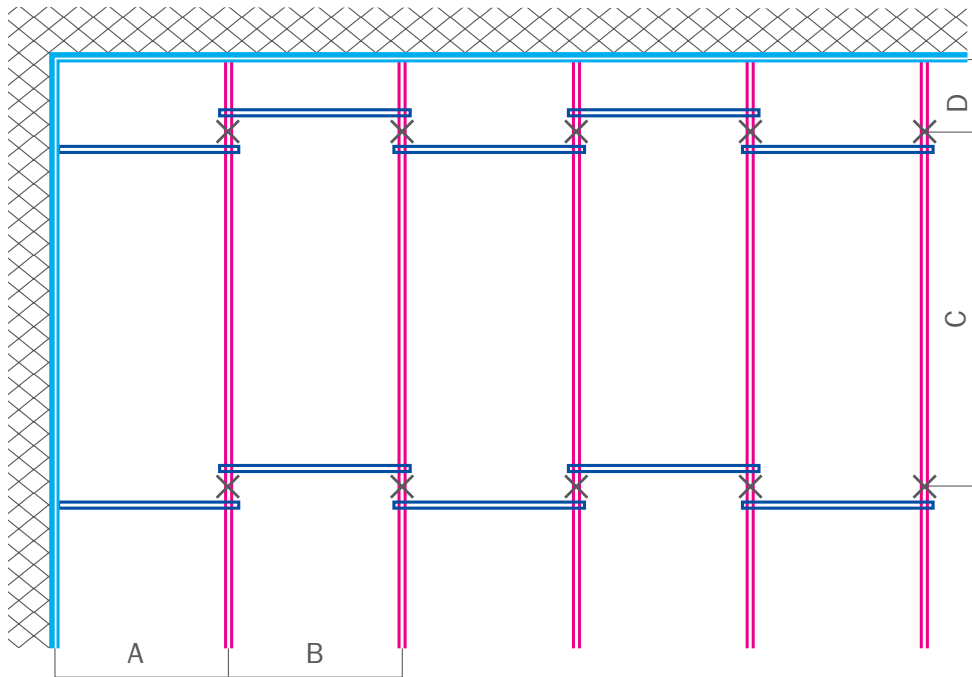

- Wall angle or stepped wall angle
- Secondary profile
- Spacer
- Quick hanger (type dependent on suspension height)

A = max. 600/625 mm B = max. 600/625 mm C = max. 1500 mm D = max. 100 mm

Possible suspended brackets:

Standard suspension:	Item numbers		Item numbers	
	23110100 23110200 23110300 23110400	Easy-span hanger hooked wire/hooked wire		20311000 Quick hanger T-profile
	23120100 23120200 23120300 23120400	Easy-span hanger hooked wire/eyelet wire		20312000 Quick hanger T-profile Klick Fix II
Rigid suspension:	Item numbers		Item numbers	
	25003000	Vernier suspended bracket, bottom part for T-profile		25001000 25001300 25001500 Vernier short hanger set, for T-profile

The alignment of the ceiling framework must always be started in the room centre. Observe the framework manufacturer's installation instructions.

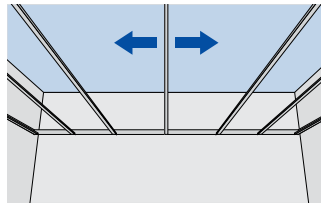

General site conditions:

- The site temperature should not fall below +5°C
- Avoid major fluctuations in temperature and humidity
- Always store the tiles in a dry place, protected against moisture
- Observe the maximum stacking height during shipping and storage
- Avoid damage to the surface finish by all means

After completion of the framework installation, check the entire ceiling surface to make sure that the secondary profiles are perfectly aligned. Adjust the easy-span hangers to make sure they fit tightly and the structure is level.

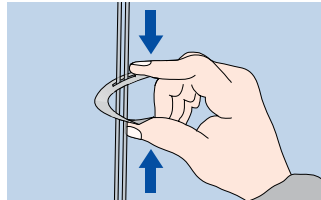

IMPORTANT!

Wear clean fabric gloves when handling the tiles.

TIP:

Make sure perimeter tiles are always bigger than half a tile! (Align the structure accordingly)

All ceiling tiles have a marking on the back. The marking indicates the direction of installation (it must always point in one direction). Failure to observe the direction of installation results in a "shadow effect".

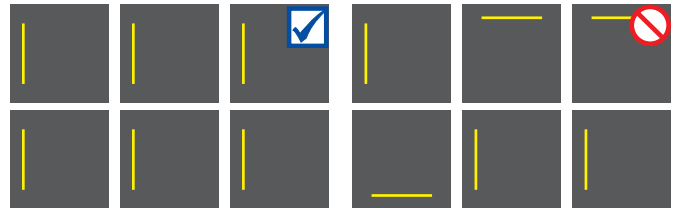
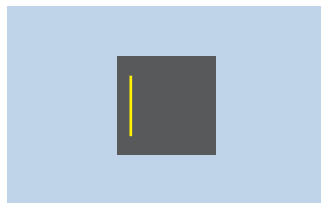

Now insert the tiles in the T-profiles observing the special features of the respective edge type. Always wear clean gloves throughout the installation work.

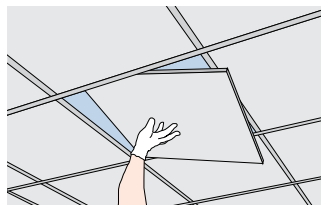

Repair & upgrade:

The special factory-applied surface texture of the tiles allows later repairs only on a minor scale. Should re-coating of the ceiling tiles become necessary, the paint must by all means be applied with a roller (see "Painting Instructions"). For this purpose, the individual tiles must be removed from the grid.



Acoustic Plaster Ceilings

VoglToptec®



Attractive in Appearance,
Highly Active in Acoustics

The acoustic plaster system with guaranteed results

Perfect acoustic plaster ceilings are a question of technique

Besides the acoustically highly effective perforated panels, acoustic plasters can also be used to significantly improve room acoustics through wall and ceiling surfaces. Each of these techniques can in itself offer a highly effective acoustic solution. Together they are an unbeatable team in terms of aesthetics and sound absorption. So far, however, working with conventional plaster base panels was more like using smooth gypsum plasterboards than a modern installation technique. VoglToptec® works quite differently and, above all, without requiring any filler.



Economical and ultra-efficient:

A milestone in acoustic plaster ceilings:

- Elimination of board jointing results in considerable increase in perforated area, thus enhancing acoustic efficiency
- Quicker and more economical installation due to precise edge to edge mounting technique
- Sound absorption coefficient of up to $\alpha_w = 0.95$ (absorption class A)
- All from one source: the complete system, perfectly harmonised and tested
- Delivery includes Vogl screw kit



Layer build-up of the finishing coats

The acoustic plaster is machine-applied onto the plaster base fleece in three time-lagged operations until an open-pored plaster layer of approx. 3 mm thickness is achieved.



VoglToptec Akustik Nano SF

Machine-applied acoustic plaster with a very fine surface texture, grain size up to 0.5 mm.



VoglToptec Akustik Color

Coloured machine-applied acoustic plaster, pigmented throughout, according to RAL or other colour charts.

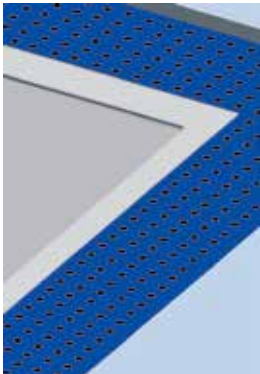

VoglToptec® acoustic plaster system panels are perforated ceiling panels with high acoustic performance (exception: type Reflexio which creates reflecting areas) for on-site lamination of the fleece plaster base (glass fibre fleece) and subsequent final coating with VoglToptec® acoustic plaster.

Acoustic fleece backing, all sides sharp-edged with undercut for installation using the quickest and most secure "edge to edge" laying principle.

Delivery including VoglToptec® screw kit (incl. perforated panel screws SN 3.5 x 30).

Standards: EN 14190 "Gypsum plasterboard products from reprocessing"
Material class: A2-s1, d0 or B1-s1, d0 (with foil) according to EN 13501
Long edge: SK (sharp-edged)
Short edge: SK (sharp-edged)









Illustration	Item number	Description	Details	m ² /pallet Pcs./pallet
	7221100010	Acoustic plaster system panel Reflexio Acoustic fleece, black	1206 x 2006 x 12.5 mm Perforated area: 0 % Mass: 10.0 kg/m ²	60.5 m ² 25 pcs.
	7221102110	Acoustic plaster system panel 8/18R Acoustic fleece, black	1194 x 2004 x 12.5 mm Perforated area: 15.4 % Mass: 8.5 kg/m ²	59.8 m ² 25 pcs.
	7221109110	Acoustic plaster system panel 12/25Q Acoustic fleece, black	1206 x 2006 x 12.5 mm Perforated area: 22.9 % Mass: 7.7 kg/m ²	60.5 m ² 25 pcs.
	7231113110	Ultracoustic panel DLV 12/25R Acoustic fleece, black	1232.5 x 1950 x 12.5 mm Perforated area: 33.9 % Mass: 6.5 kg/m ²	60.0 m ² 25 pcs.
	7221100080	Acoustic plaster system panel 12/25Q Acoustic fleece, black and foil	1206 x 2006 x 12.5 Perforated area: 22.9 % Mass: 7.7 kg/m ²	60.5 m ² 25 pcs.

VoglToptec® ultracoustic panel

The panel with integrated mounting instruction, thanks to surrounding and transverse screw-fixing and stop bars. Perfect evenness and enormous stability despite the very high degree of perforation of 33.9 %.



Illustration	Item number	Description	Contents	PU PU/pallet
	90501300	Vogl Supergrund primer LF 20I Universal primer, absorbency regulating, free from solvents and softening agents, low-emission, free from active fogging substances.	1 canister = 20 litres	1 PU = 1 canister 24 canisters/pallet
	90605000	VoglToptec® plaster base fleece Special glass fibre fleece as plaster base for coating with acoustic plaster, not flammable, A2, crack-bridging properties, moisture-resistant, dimensionally stable, white colour.	Roll width 1145 mm Roll length 100 m	1 PU = 1 roll 15 rolls/pallet
	90608000	VoglToptec® plaster base fleece, small Special glass fibre fleece as plaster base for coating with acoustic plaster, not combustible A2, crack-bridging, damp-proof, dimensionally stable, white colour. The handy-sized roll of plaster base fleece is especially suited for applying wallpaper in the perimeter/wall connection area as well as for custom solutions.	Roll width = 500 mm Roll length = 100 m	1 PU = 1 roll
	90604000	VoglToptec® special adhesive Ready-to-use, dispersion adhesive, tested for harmful substances, for bonding the plaster base fleece to perforated ceiling panels, free from solvents and softening agents, low-emission, free from active fogging substances, ready-mixed product.	1 bucket = 16 kg Consumption: approx. 0.3 kg/m ²	1 PU = 1 bucket 24 buckets/pallet
	90602000	VoglToptec® Akustik Nano SF Decorative, open-pored, machine-applied acoustic plaster, very fine texture, grain size up to 0.5 mm, dull matt, high degree of whiteness, ready-mixed product.	1 bucket = 18 kg Consumption: 2.7 - 3.0 kg/m ²	1 PU = 1 bucket 24 buckets/pallet
	90602100	VoglToptec® Akustik Color Nano SF Decorative, open-pored machine-applied acoustic plaster, very fine texture, grain size up to 0.5 mm, ready-mixed product; please specify colour of choice (RAL etc.) when ordering.	1 bucket = 18 kg Consumption: 3.0 - 3.5 kg/m ² *	1 PU = 1 bucket 24 buckets/pallet

*Note: Dark or special colour shades may lead to increased consumption. Actual quantities depend on the respective project.

System-inherent reliability!

The perfectly harmonised components are system tested and guarantee unparalleled reliability in terms of installation and performance of our acoustic plaster ceilings.

- 1 Acoustic fleece (and foil, if any) factory-supplied
- 2 VoglToptec® Acoustic plaster system panel
- 3 Plaster base fleece installed on-site
- 4 Acoustic plaster applied on-site

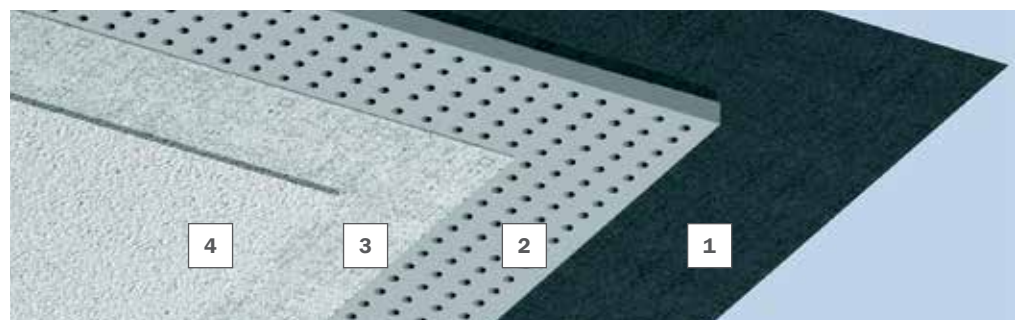

The primary profiles are rigidly hung from the structural soffit with suspended brackets using fixing materials approved by the relevant building authorities.

The centre distance and the number of suspended brackets as well as the fixing material are subject to site requirements and EN 13964/ DIN 18181. The CD 60/27 secondary profiles are attached to the CD 60/27 primary profiles using cross connectors.

CD 60/27 are extended using straight connectors. For primary grid profiles, always ensure that the joint is close to a suspended bracket

(max. 100 mm). Joints should generally be staggered.

The plasterboards should be installed in accordance with EN 13964/ DIN 18181 and the manufacturer's guidelines.

Additional items such as lighting, ventilation, sprinkler systems etc. must be individually suspended.

Any changes in the framework owing to integrated ceiling components must be considered.

Framework, VoglToptec®								
Technical data	Unit	Perforated panel ceiling						
Panel thickness	mm	12.5						
Distributed load	kN/m ²	≤ 0.15					≤ 0.30	
Centre distance of suspended bracket A	mm	1150	1050	1000	950	900	900	750
Centre distance of primary profiles X	mm	600	800	900	1000	1100	600	1000
Centre distance of secondary profiles Y	mm	see table below						

Article	Unit	Centre distance of secondary profiles Y
VoglToptec® Acoustic plaster system panel 8/18R, 12/25Q, Reflexio (smooth)	mm	334
VoglToptec® Ultracoustic panel 12/25R DLV	mm	325

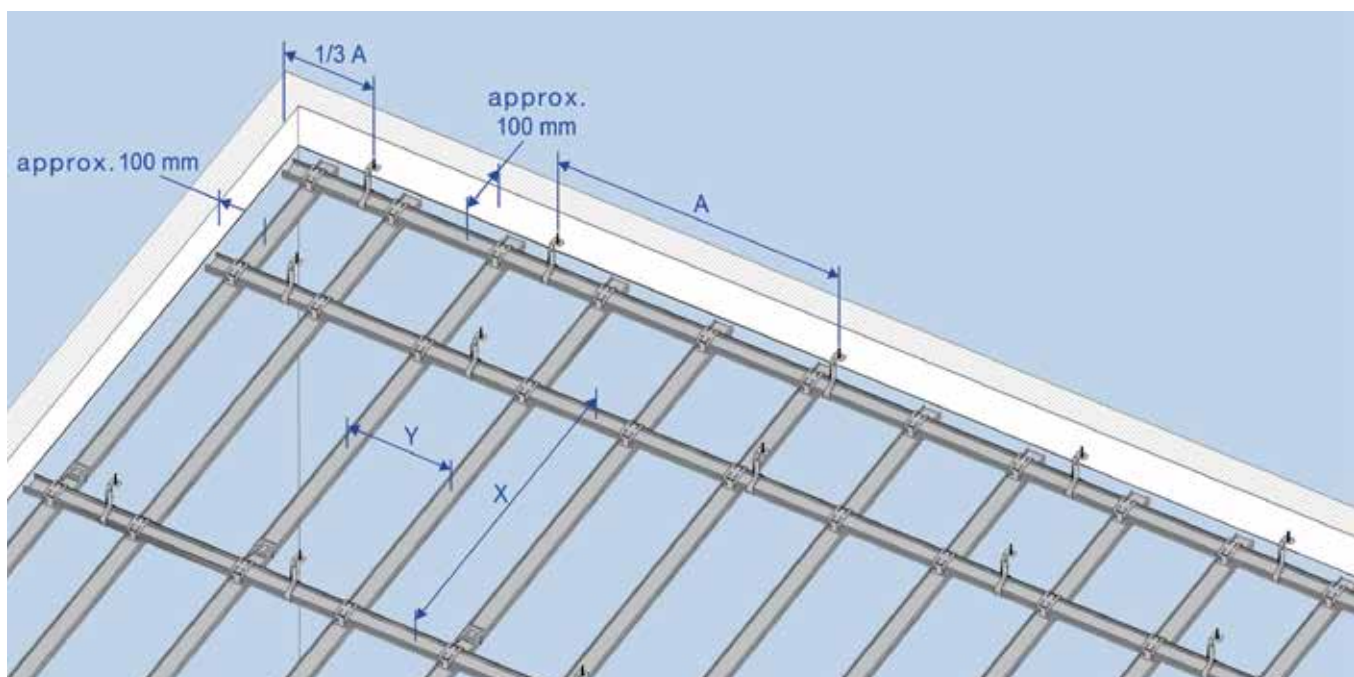

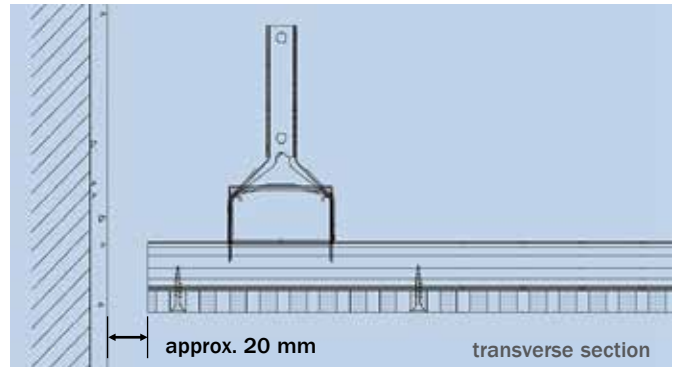
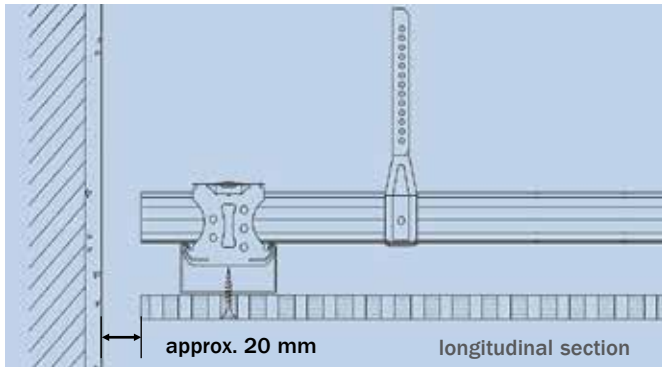

Wall connection:

To avoid different pressures/temperatures between the ceiling void and useable space, we recommend ventilating the ceiling. To do this, we advise you to fit the wall connection with an open shadow gap (approx. 20 mm) in the VoglToptec® system.

Please contact us if you require additional regulation details concerning the VoglToptec® system.

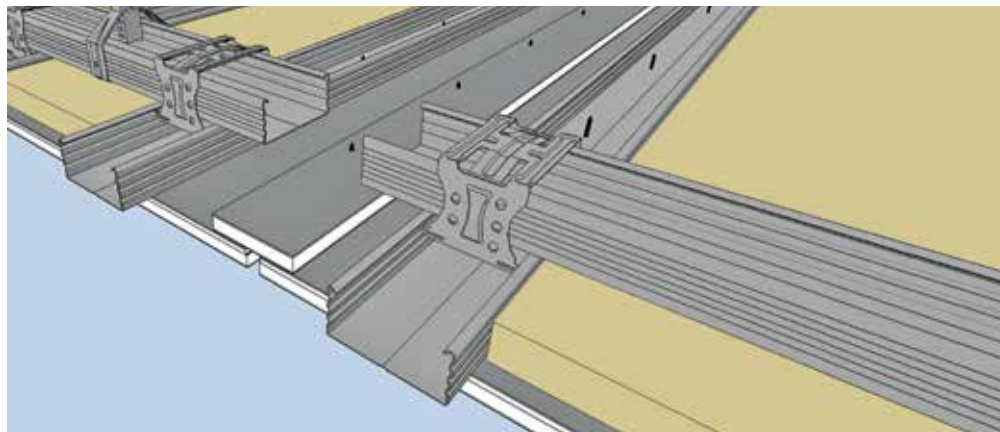

Expansion joints:

To prevent cracking in the ceiling surface, expansion joints have to be provided every 10 linear metres/100 m² of the ceiling area.

The framework must be completely severed (see illustration) and the panel strips above the joint must be screwed down on one side only.

Material required per m² based on a ceiling of 100 m² (10 m x 10 m, not considering loss or waste, approximate values):

Metal framework, suspended bracket centre distance 1000 mm, primary profile spacing 900 mm, secondary profile spacing 333 mm			
Item number	Article description	Unit	Quantity
Fixation			
Standard	Safety nail, DN 6 x 35	piece	1.3
Suspended brackets			
2016X000	Direct suspended bracket 50/120/200 and	piece	1.3
50809000	Tapping screw LN 3.5 x 9.5	piece	2.6
or			
20128/20151	Vernier hanger/vernier bottom part and	piece	1.3
25501000	Vernier safety bolt and	piece	1.3
25XXX000	Vernier top part, 200 - 2000 mm, custom lengths on request	piece	1.3
Profiles and connectors			
100XX000	CD profile 60/27/0.6 rK, L=XXX mm	m	4.1
20159000	Connector, lengthwise, CD 60/27	piece	0.8
20135000	Cross connector, CD 60/27	piece	3.3
52130000	Perforated panel screw SN 3.5 x 30	piece	22

VoglToptec® Thermotec The perfect solution for your acoustic plaster climate control ceiling

You want your acoustic plaster ceiling to be both visually attractive and provide efficient climate control performance? Then our VoglToptec® Thermotec system is just the right system for your project!

With the perfect combination of 10 mm VoglThermotec® panels and VoglToptec® acoustic plaster system, you will get optimum cooling capacity combined with sound absorption performance and an attractively finished surface. And of course, with our in-built reliable results – as all the system components come from the ceiling specialist Vogl Deckensysteme.



VoglToptec® backed with special foil The right choice if you want your ceiling to be impermeable to airflow

As you might know, a ventilation system is often required to be installed within the ceiling void to meet air exchange requirements. In many cases, this ventilation is to take place only through the ceiling joints at the perimeters, and the rest of the ceiling surface must be airtight. Now there is a safe and easy-to-use solution for this application in the VoglToptec® system. With our special foil, laminated on the reverse of the boards, the acoustic plaster ceiling remains impermeable to airflow – but without compromising its acoustic performance. The ideal product if your finished ceiling ever comes “under pressure”.



Check ceiling framework for rigidity and evenness (using a straightedge).

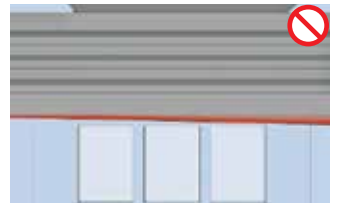

Then check ceiling grid CD sections for centre distances and adjust, if necessary. Always mount straight connectors in a staggered manner (see figure). Measure centre distances accurately!

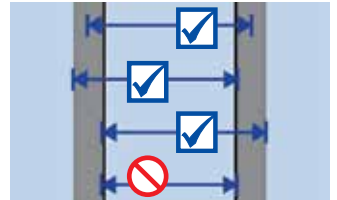
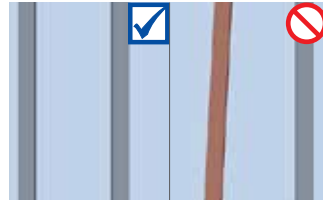
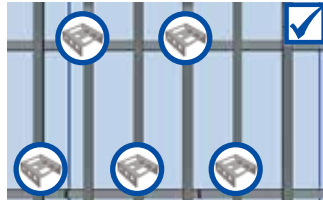

As viewed from entrance area, choose panel arrangement with short edges parallel to windows (main direction of light).



Exception: Ultracoustic panels with inherent screw bars.

Locate centre of room to position first ceiling panel, also taking into account resulting ceiling perimeter to wall connections.



We recommend the following assembly accessories:

Perforated panel screws, including screw bit

Correct handling of ceiling panels:

- Always take into account the load carrying capacity of the building when storing ceiling panels
- Do not store ceiling panels upright, but always flat on panel pallets
- Always carry ceiling panels with short edges upright
- Protect ceiling panels from moisture; relative humidity should be 40 - 80 %
- Avoid major temperature fluctuations
- Do not expose stored ceiling panels to direct sunlight

Get panel to correct position on framework using a panel lifter if working alone, or else another worker's help.



Perforation pattern	Centre distance
Acoustic plaster system panel 8/18R, 12/25Q, Reflexio	334 mm
Ultracoustic panel 12/25R DLV	325 mm

Screws must be put into panel at right angles, and countersunk head screwed down to 0.5 mm below visible surface of ceiling panel.

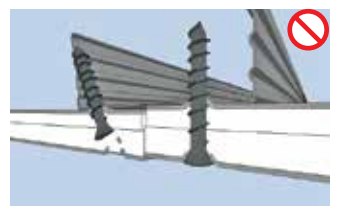
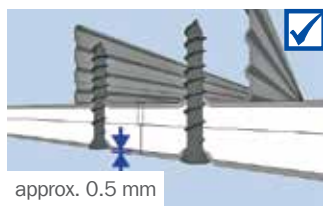

Screws should be spaced maximum 170 mm from fixing point to fixing point. The distance between screw and panel edge shall not exceed 26 mm. Avoid damaging acoustic design panels by countersunk heads.

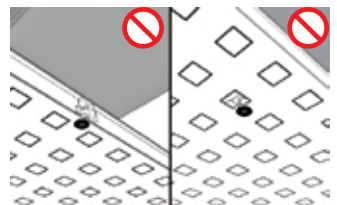
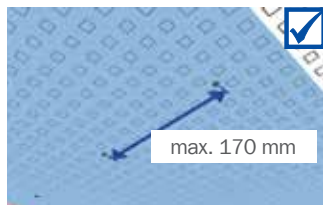

First, screw the ceiling panel to the framework in the centre of the panel, then lower the panel lifter and fix a screw in the centre of each short edge before finally screwing down long edges.

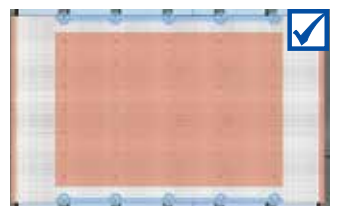
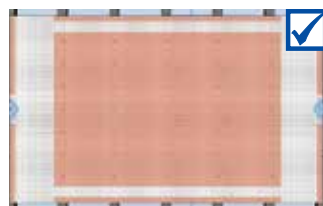

Take note of panel labelling (stamp) and mount in direction of reading (all stamps should point in same direction).



Use CD profile or straightedge as end stop. Position next panel by sliding it to first alongside CD profile/straightedge and fix in place.



General site conditions/Manufacturer's instructions:

- Take movement joints of building structure into account
- Plan to include expansion joints after approx. every 10 m or approx. 100 m²
- Cardboard layer must not be penetrated by screws, but merely displaced downwards
- Working temperature should be at least +10 °C and job site temperature not below +5 °C
- Installed ceiling surfaces must not be connected to perimeter walls
- Place any damping (mineral wool layer) directly onto the ceiling panels
- Carry out any additional work on ceiling (access openings, lighting recesses, etc.) immediately after installing ceiling panels

Fix screws in panel joint area using alternating pairs across panels ("zig-zag" principle), starting left or right next to screw which has already been fixed. This will create flush joint areas.

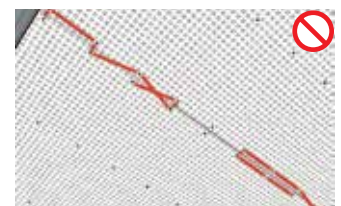
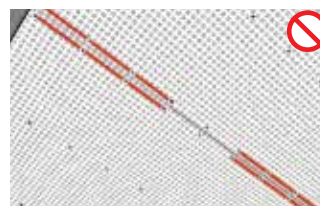
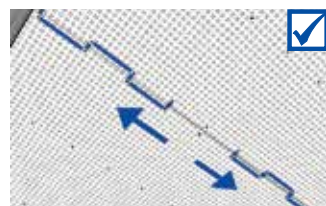

Install ceiling panels first lengthways, then crossways, resulting in cross arrangement on ceiling. Cover remaining areas in same manner, working from centre of room outwards.

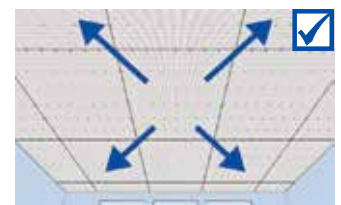

Lay remaining ceiling panels edge to edge, always checking that joints are level and using "cross joint" system only.

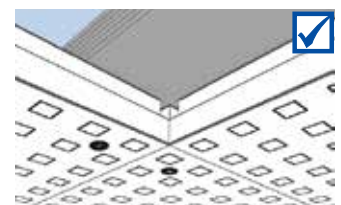
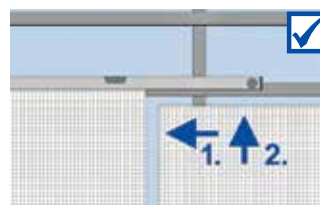

After all panels have been installed, recheck that all joints are level and adjust, if necessary, using a screwdriver. Then check with a straightedge.

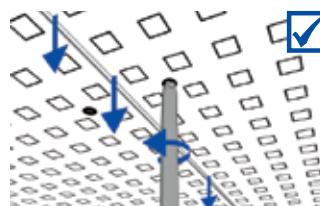
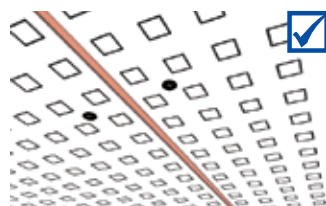

Place any damping layer directly onto back of ceiling panels. We recommend fitting an open shadow gap at the wall connection.

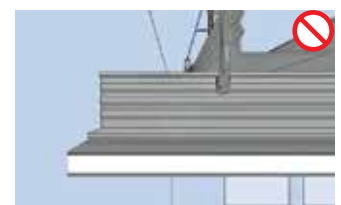
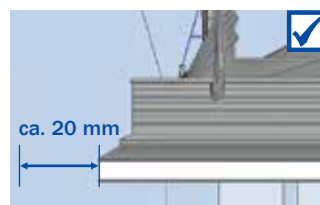
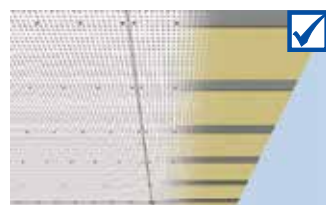

Provide for expansion joint of 5 to 10 mm every 10 linear metres/100 m².

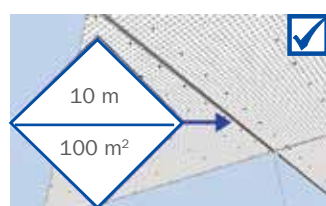

Additional board strip above joint must be screwed down on one side only.



Check panel joint areas and screw heads and adjust any height discrepancies using a screwdriver.

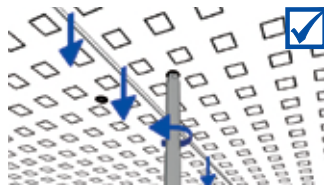

Prime ceiling surface with Vogl Supergrund LF. Subbase must be dry and free from dirt and separating substances. Apply primer in undiluted state using lambskin roller.



Drying time: 12 hrs



General site conditions/Manufacturer's instructions:

- Store primer, adhesive and acoustic plaster in ** frost-free environment **
- Reclose containers for extended work breaks
- Stir all materials well before use
- Working temperature should be at least +18 °C and job site temperature not below +10 °C
- Relative humidity: 40 - 80 %
- Self-levelling, cement or asphalt screeds must be fully dried – make sure there is no residual moisture
- Avoid shock heating or cooling of rooms during installation or drying times to prevent cracking
- Store away from sun and heat

Apply VoglToptec® Special Adhesive generously and evenly using lambskin roller and immediately install plaster base fleece into wet adhesive bed pushing it in with a wallpaper smoother. **Do not** spray-apply adhesive.



While applying fleece, make sure that special adhesive has not started to dry as this can cause bubbles. Place further lengths of plaster base fleece overlapping (5 - 10 cm) and separate using a double cut.



Check surface and joints. There must not be any adhesive on visible face of fleece (light marks).



Drying time: min. 12 hrs



Stir VoglToptec® Nano SF acoustic plaster slowly before use (2 - 3 minutes).



VoglToptec® Nano SF = ready-mix

Final coating of acoustic plaster - Manufacturer's instructions:

- Machine requirements: plaster spray system with worm conveyor (e.g. Strobot 204S) or delivery pump (e.g. InoBeam M8) and high-performance compressor (400 – 600 l/min)
- Spray distance (nozzle to ceiling) approx. 700 - 900 mm
- Air flow 1.5 - 2.0 bar
- Nozzle size 4 – 6 mm (depending on desired texture)
- Application quantities:
 1st coat approx. 700 g/m²
 2nd coat approx. 900 g/m²
 3rd coat approx. 1100 g/m²
 Total approx. 2700 g/m²

Optimum speckling pattern must be adjusted depending on job site.



(using brown cardboard, etc.)

Apply first layer by spraying-on acoustic plaster in circular motion.

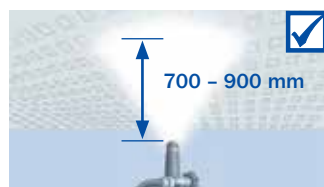

Attention – avoid development of paint mist; holes must remain visible.

Drying time: 5 hrs



After drying period, apply 2nd coat to ceiling, also in circular motion; holes still slightly visible.

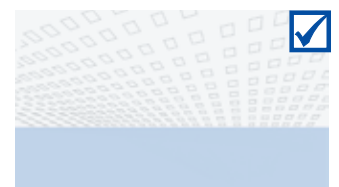
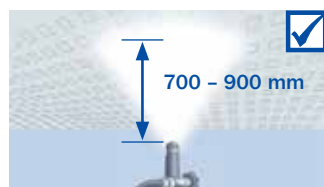

Drying time: 12 hrs



After drying period, apply 3rd coat to ceiling, also in circular motion; holes no longer visible.

Drying time: 12 hrs

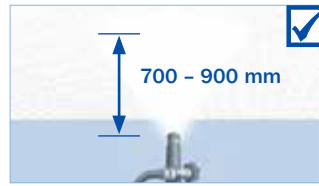

Renovation/renewal of acoustic plaster coating

To remove any soiling, the ceiling can be given another machine-applied coating. Before application, sweep the ceiling with a fine hair broom.

Attention: Applying paint will affect the acoustic properties of the ceiling!



With circular motions, apply another coat to the ceiling surface. Depending on the degree of soiling, the application quantity of acoustic plaster can vary.

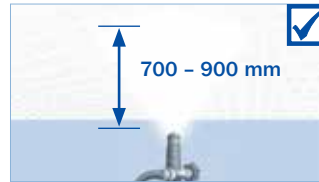

Quantities required for final coating per m² (not considering loss or waste)

Item number	Article description	Unit	Quantity
90501300	Vogl primer Supergrund LF	l	approx. 0.15
90604000	VoglToptec® special adhesive	kg	approx. 0.30
90605000	VoglToptec® plaster base fleece	m ²	approx. 1.00
90602000	VoglToptec Akustik Nano SF	kg	approx. 2.70 - 3.00
90602100	VoglToptec® Akustik Color Nano SF	kg	approx. 3.00 - 3.50

Acoustic plaster ceiling – VoglToptec® system

Acoustic plaster ceiling as suspended ceiling structure, one side clad with VoglToptec® acoustic plaster system panels, backed with acoustic fleece, mounted to a rigid ceiling framework of galvanised metal profiles, hung with flush and horizontally aligned suspended brackets and installed using fixing materials approved by the building authorities, with or without damping layer depending on building physics requirements. Installation in accordance with manufacturer's instructions, including all connection and jointing work as well as connection and fixing materials.

Ceiling system to accommodate an on-site application of machine-applied plaster consisting of VoglToptec® plaster base fleece and final coating using VoglToptec® acoustic plaster in accordance with manufacturer's instructions.

System structure

Framework in accordance with DIN 18181:2007-02

Profiles:

Pressure-resistant design made from galvanised sheet steel profiles CD 60/27 as primary and secondary profiles in accordance with EN 14195

Suspended brackets:

- Suspend with vernier systems (top part, vernier hanger),*
- Suspend with vernier systems (top/bottom part),*
- Suspend with direct suspended brackets, *
- Use fixing materials approved by the relevant building authorities.

Connection:

For primary-secondary profile connection with cross connectors, use suspended brackets and cross connectors in accordance with EN 13964,

suspended bracket centre distance: max. 900 mm,
primary profile centre distance: max. 1.100 mm,
secondary profile centre distance: 325/334 mm.*

Covering:

Acoustic plaster system panels are perforated ceiling panels in accordance with EN 14190, backed with acoustic fleece, one layer 12.5 mm, laid edge to edge and fixed to the framework using perforated panel screws SN 30, with screw spacing max. 170 mm. Observe manufacturer's installation guidelines.

Perforation pattern/perforated area/mass per unit area:

- Reflexio/0.0 %/10.0 kg/m² *
- 8/18 round/15.4 %/8.5 kg/m² *
- 12/25 round/22.9 %/7.7 kg/m² *
- Ultracoustic 12/25R DLV/35.3 %/6.5 kg/m² *

Distributed load:

- Less than or equal to 0.15 kN/m² *
- Less than or equal to 0.30 kN/m² *

Joint finishing:

VoglToptec system in accordance with manufacturer's instructions, edge to edge installation principle, filler-free. Sand down area of screw heads and panel joints level, paying attention to leave the screw heads unsanded. No filling required. Observe manufacturer's installation guidelines.

Subbase:

Suspension height: h = mm
Installation height: h = mm
Room height: h = mm
Insulation thickness: th = mm

Subsequent application: final coating in VoglToptec® System

Complete system: Vogl Deckensysteme, or equivalent

* Delete as applicable



VoglThermotop®



Highly Efficient

in Energy Conservation

Modern heating and cooling from above

The use of cooling and heating ceilings

Today's buildings have to satisfy a wide variety of demands. The focus is always the users of the building. The building must provide the best possible conditions for them to work efficiently and productively. People can achieve optimum performance only in an optimum environment. A crucial requirement for pleasant and performance-oriented work is an efficiently designed workplace. A prevalent aspect here is the feel-good factor. It is achieved by maintaining agreeable room temperatures. This condition is realised by integrating cooling and heating systems with high radiation effect into suspended ceilings. In this process, ventilation is reduced to the absolutely necessary and induced with the lowest possible speed. An excellent way to realise this is to use the VoglThermotop® system. Together with our system partner RiLO Systemtechnik, we support you in your cooling and heating ceiling project from the design to the tendering process to the execution.



VoglThermotop® system description

All system components of the VoglThermotop® system are perfectly harmonised to ensure optimum application and result reliability.

Following the framework installation, GKH system suspenders are used to attach the cooling/heating coils to the framework. The GKH system suspender locks in place in the CD profile audibly. This way of locking the coils ensures their accurate positioning within the framework.

The special "RiLO GKH system suspenders" which hold the copper tube bundle and are locked into bearing framework between the CD profiles are structurally pre-stressed – which ensures the contact between the heat-conducting profiles and the covering panels.

The heat is transmitted by heat conducting profiles shaped in a way to both hold the copper tube and ensure the greatest possible area of contact to the outside of the copper tube. The heat conducting profiles are located on the straight stretches of the tubing, in between the opposite 180-degree elbows.

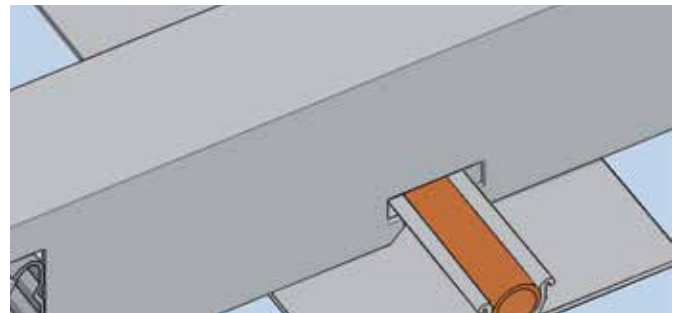
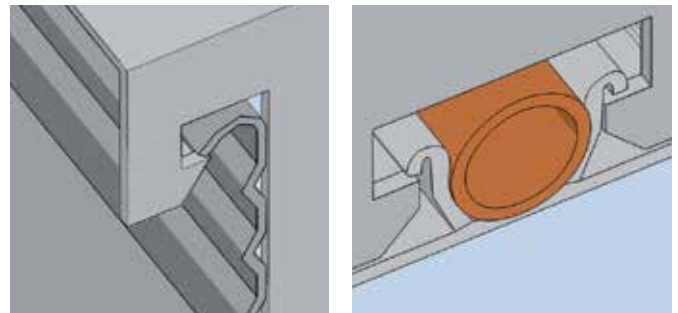

Less energy, more performance

With energy resources growing scarce, fossil fuels are too valuable to just burn them on a large scale. To conserve the fossil resources, it makes good sense to put major energy consumers on a diet. This includes the heating and cooling of buildings. Highly efficient systems are needed here. The VoglThermotop system combines acoustic design ceilings with the additional function of a very effective cooling and heating ceiling. Compared to conventional air handling systems, the operating costs can be reduced by up to 40%, and, from an aesthetic point of view, the harmonious appearance of the ceiling is not compromised. VoglThermotop offers unlimited design liberty when it comes to shape and functionality.



The cooling and heating ceiling for maximum efficiency:

- Perfectly easy to install the pre-assembled units in the finished ceiling framework by simply hooking and snapping them into place
- Tested complete system from one source with integrated result reliability
- Available as smooth cooling and heating ceiling, perforated cooling and heating ceiling, cooling and heating ceiling with acoustic plaster system or floating cooling and heating ceiling
- Individual design and execution to achieve maximum efficiency from the surfaces available for activation
- Low operating costs due to low-maintenance complete system, minimum susceptibility to failure thanks to the use of long-time tested materials
- Highly flexible system for multi-functional expansions – such as lighting, sound and safety systems as well as more building services

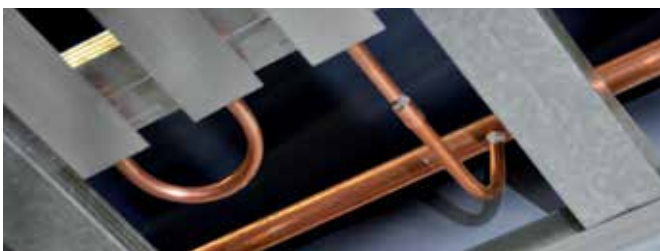

Flush level installation

The completely pre-assembled coil units are simply hooked into the bearing grid from above.



Undisrupted flow

All tube ends are protected for transport and intermediate storage. Tube ends free of chips from cutting, with no outer burr or deformation, ensure a perfect permanent bond in the brazing process.

The primary profiles are rigidly hung from the structural soffit with suspended brackets using fixing materials approved by the relevant building authorities. The centre distance and number of suspended brackets, as well as the fixation, are subject to site requirements and EN 13964/DIN 18181. The CD 60/27 secondary profiles are attached to the CD 60/27 primary profiles using cross connectors.

CD 60/27 are extended using straight connectors. For primary grid profiles, always ensure that the joint is close to a suspended bracket (max. 100 mm). For primary and secondary profiles, joints are generally offset from each other.

The plasterboards should be installed in accordance with EN 13964/ DIN 18181 and the manufacturer's guidelines.

Additional items such as lighting, ventilation, sprinkler systems etc. must be individually suspended.

Any changes in the framework resulting from additional ceiling mounted items must be considered.

Framework of VogIThermotop®

Technical data	Unit	Perforated panel ceiling						
Panel thickness	mm	10.0						
Distributed load	kN/m ²	≤ 0.15					≤ 0.30	
Centre distance of suspended bracket A	mm	1150	1050	1000	950	900	900	750
Centre distance of primary profiles X	mm	600	800	900	1000	1100	600	1000
Centre distance of secondary profiles Y	mm	see table below						

Article	Unit	Centre distance of secondary profiles Y
Acoustic design panel 6/18; 8/18; 8/18Q; 10/23; 12/25; 12/25Q; 8/12/50; 8/15/20; 12/20/35	mm	333
Acoustic design panel 15/30 12/20/66	mm	330
Acoustic slot panel 5/82/15.4	mm	250
VogIToptec® (acoustic plaster system) 8/18R 12/25Q Reflexio (smooth)	mm	334
VogIToptec® (acoustic plaster system) Ultracoustic panel 12/25R DLV	mm	325

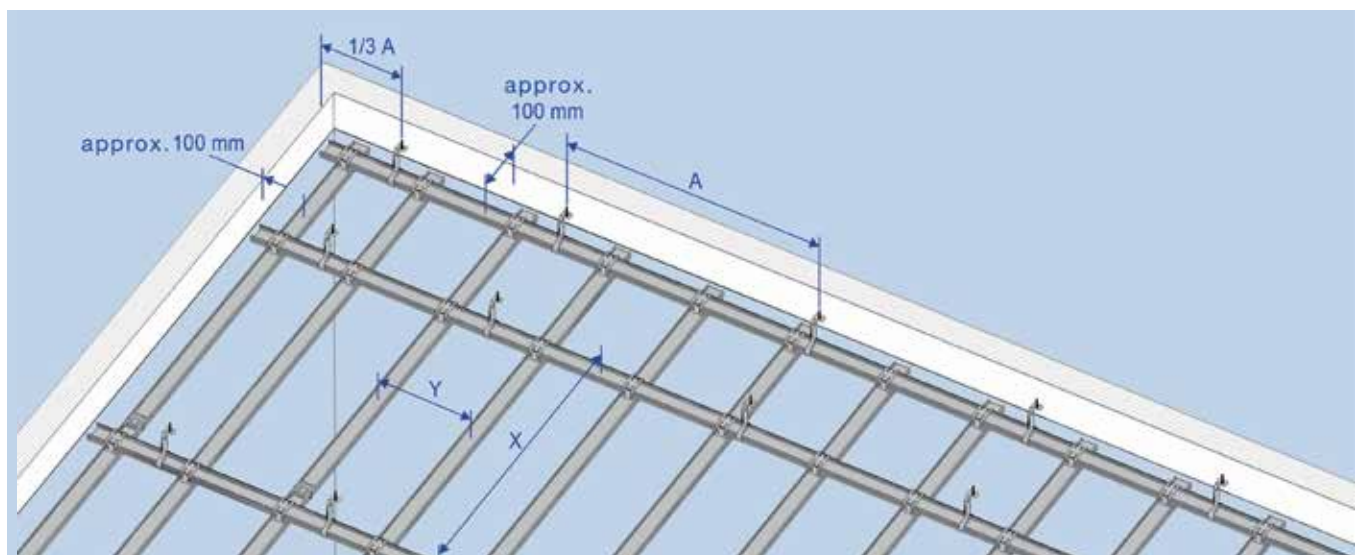

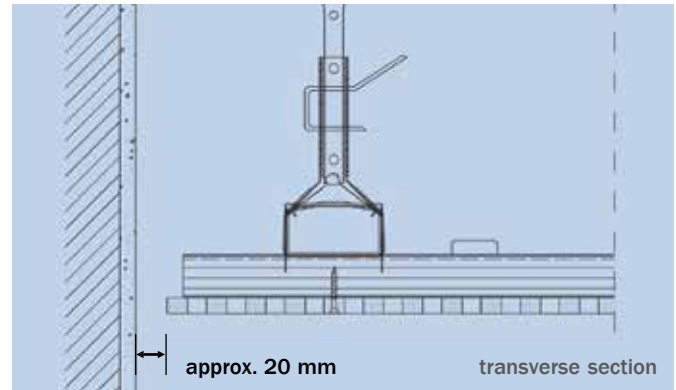
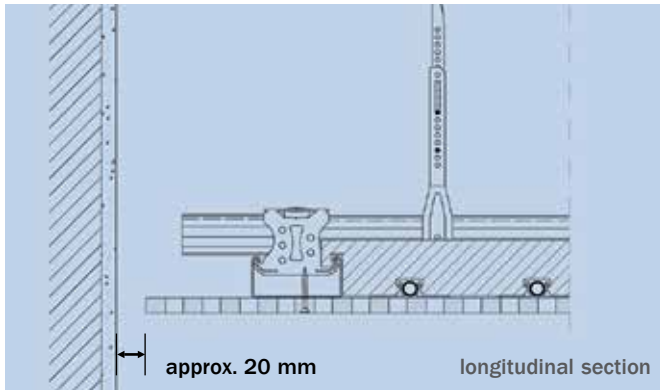

Wall connection:

Due to the thermally induced expansions of the cooling/heating ceiling, we recommend creating wall connections in a way to allow the absorption of movements, for example by providing an open shadow gap (approx. 20 mm).

Please contact us if you require additional regulation details concerning the VoglThermotop® system.

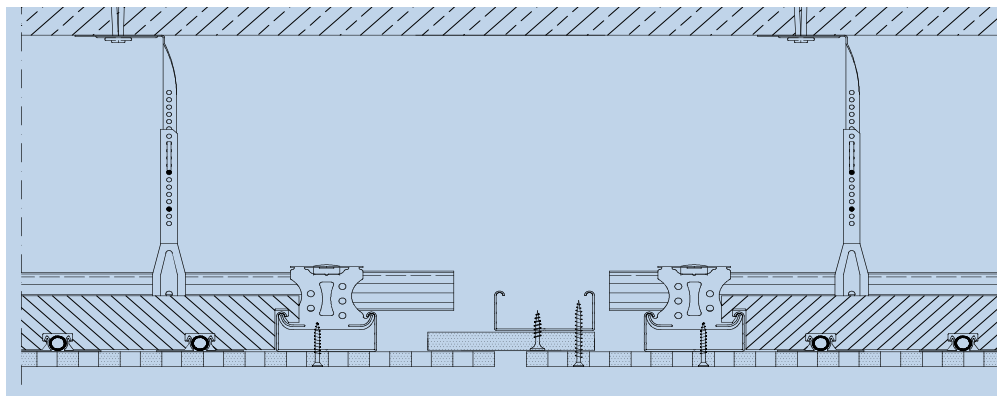

Expansion joints:

In order to avoid cracking in the ceiling surface, appropriate expansion joints shall be provided for cooling ceilings every 10 running metres / 100 m² and for combined cooling and heating ceilings even with a side length of 7.5 running metres.

The framework must be completely severed (see illustration) and the panel strips above the joint fixed to one side only.

Material required per m² based on a ceiling of 100 m² (10 m x 10 m, not considering loss or waste, approximate values):

Metal framework, suspended bracket centre distance 1000 mm, primary profile spacing 900 mm, secondary profile spacing 333 mm

Article no.	Article description	Unit	Quantity
Fixation			
Standard	Safety nail, DN 6 x 35	pcs.	1.3
Suspended bracket			
2016X000	Direct suspended bracket 50/120/200 and	pcs.	1.3
50809000	Tapping screw LN 3.5 x 9.5	pcs.	2.6
or			
20128 / 20151	Vernier hanger / vernier bottom part and	pcs.	1.3
25501000	Vernier safety bolt and	pcs.	1.3
25XXX000	Vernier top part, 200-2000 mm, custom lengths on request	pcs.	1.3
Profiles and connectors			
100XX000	CD profile 60/27/0.6 rK, L=XXX mm	m	4.1
20159000	Connector, lengthwise, CD 60/27	pcs.	0.8
20135000	Cross connector, CD 60/27	pcs.	3.3

Various designs and surfaces – individually tuned to your project

Whether low, medium or high cooling capacity, whether perforated or smooth surfaces: all options are open to you with the VogIThermotop® cooling and heating ceiling. The variations our system offers suit your requirements perfectly and guarantee you a complete solution from one source, ideally tuned to your project.

Maximum efficiency through individual coil configuration per area

Versatility and flexibility are given through the use of three- or four-row cooling coils combined with various widths of heat conducting profiles.

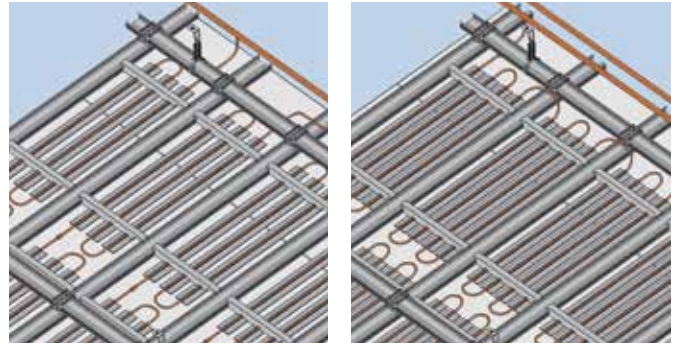

The right type of panel for every demand

When designing your project, you have the choice between two panel types – the VogIThermotec panel or the VogIThermotec panel Plus. With a panel thickness of 10.0 mm, both panels have an increased thermal conductivity. The VogIThermotec panel Plus is, moreover, equipped with a graphite-modified gypsum core for enhanced performance.



VogIThermotec panel

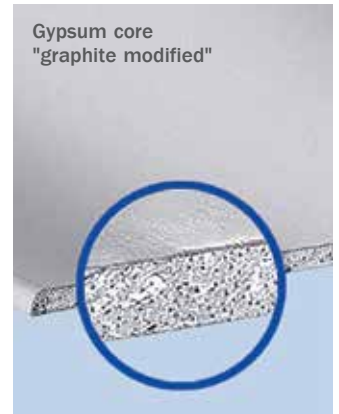

VogIThermotec panel Plus

Surface diversity into the bargain

Whether you desire one of our 12 perforation patterns or a finish with the VogIToptec® acoustic plaster system – you have all options open with the VogIThermotop® cooling and heating ceiling system. Of course, it is also no problem to have your ceiling finished as a smooth plasterboard ceiling.

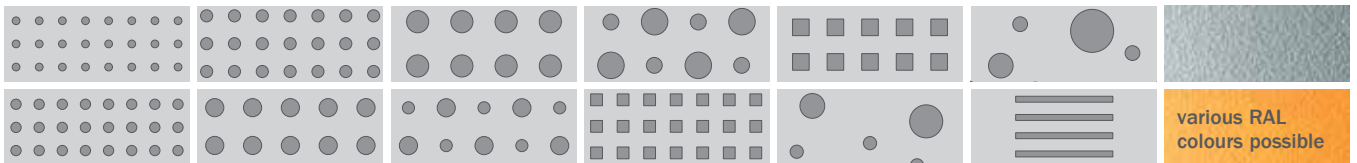

Cooling coils and GKH system suspenders are delivered in separate packaging. GKH system suspenders are installed on site.



Note:

Observe the system instructions by RiLO Systemtechnik when installing the tubing and commissioning the cooling and heating ceiling system! Furthermore, we refer to the requirements and guidelines of the federal registered association of surface heating and surface cooling systems.

Slip GKH system suspenders onto cooling coils evenly, with cooling coil holders always pointing in same direction.

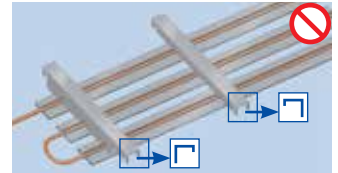
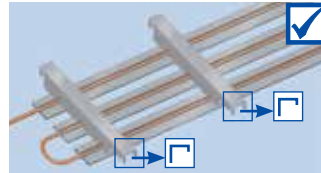

Centre distances of the GKH system suspenders < 900 mm; maximum distance to edge of cooling coil < 100 mm.

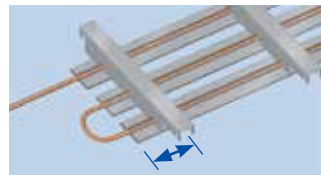
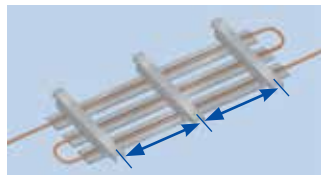

Hook cooling coil into CD secondary profile at an angle while pushing it up at the same time and snapping it into place. Check to make sure GKH system suspender has "clicked" into CD profile, otherwise snap it in manually.

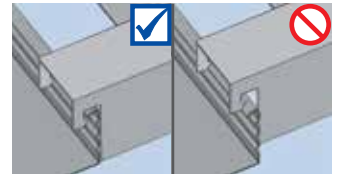

Cooling coil is pushed upward minimally during panel installation so as to provide full contact with the Thermotec panel.

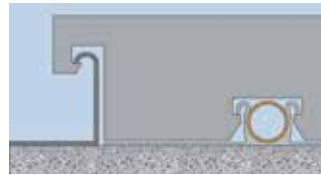

The specified performance values of the VoglThermotop® and VoglThermotop Plus® systems are based on the following:

Cooling performance of a room cooling surface

Determination of performance values according to DIN EN 14240:2004-04

The tests in accordance with DIN EN 14240 were carried out by a certified, recognised German testing institute.

(The figure on the right shows exemplary thermographic images)

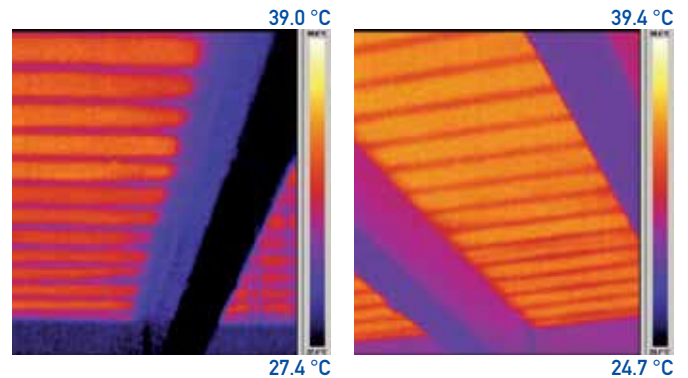

VoglThermotop®, smooth, RiLO coil CU50-GK

Type: non-perforated plasterboards 10 mm with meander elements of heat conducting aluminium profiles with pressed-in meandering copper tube

Cooling performance per m²
as per DIN EN 14240

$\Delta\theta_N = 8\text{K} \rightarrow 59.2\text{ W/m}^2$

$\Delta\theta = 10\text{K} \rightarrow 75.0\text{ W/m}^2$

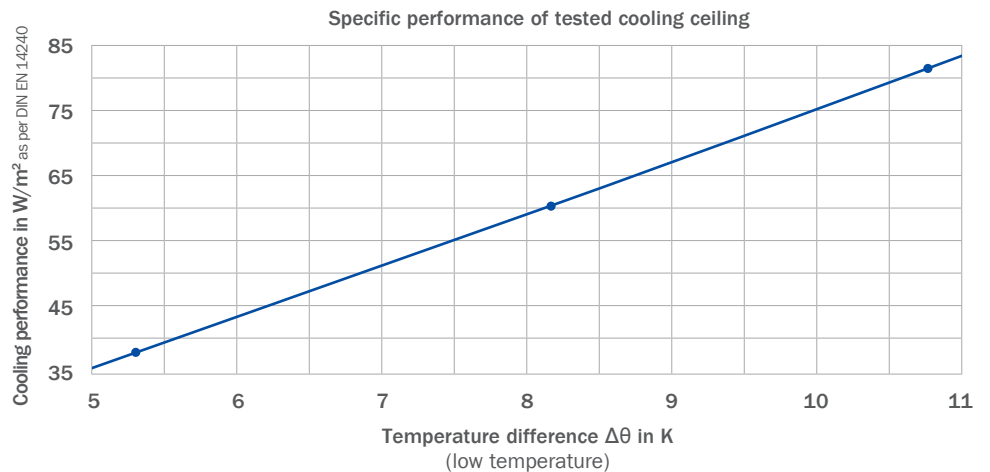

VoglThermotop®, smooth, perforation pattern 12/25Q, RiLO coil CU50-GK

Type: perforated plasterboards 10 mm, perforation 12/25Q, with meander elements of heat conducting aluminium profiles with pressed-in meandering copper tube

Cooling performance per m²
as per DIN EN 14240

$\Delta\theta_N = 8\text{K} \rightarrow 59.2\text{ W/m}^2$

$\Delta\theta = 10\text{K} \rightarrow 75.1\text{ W/m}^2$

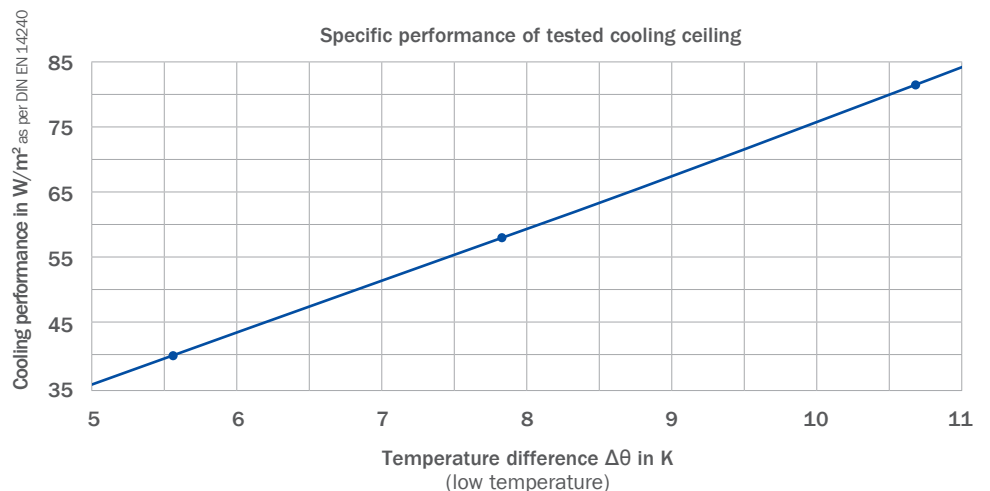

VoglThermotop® PLUS, smooth, RiLO coil CU50-GK

Type: non-perforated plasterboards 10 mm (including share of graphite) with meander elements of heat conducting aluminium profiles with pressed-in meandering copper tube

Cooling performance per m²
as per DIN EN 14240

$\Delta\theta_N = 8K \Rightarrow 72.8 \text{ W/m}^2$

$\Delta\theta = 10K \Rightarrow 92.8 \text{ W/m}^2$

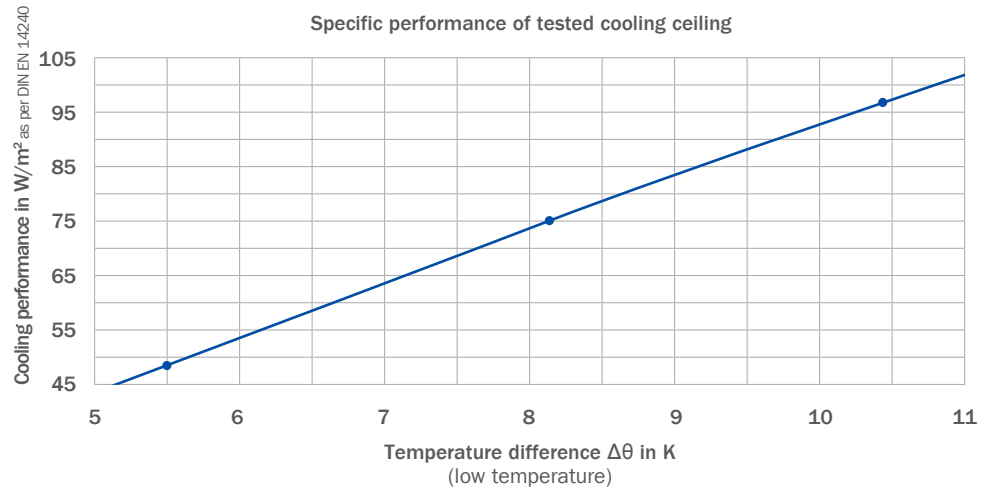

VoglThermotop® PLUS, smooth, perforation pattern 12/25Q, RiLO coil CU50-GK

Type: perforated plasterboards 10 mm (including share of graphite), perforation 12/25Q, with meander elements of heat conducting aluminium profiles with pressed-in meandering copper tube

Cooling performance per m²
as per DIN EN 14240

$\Delta\theta_N = 8K \Rightarrow 68.7 \text{ W/m}^2$

$\Delta\theta = 10K \Rightarrow 87.2 \text{ W/m}^2$

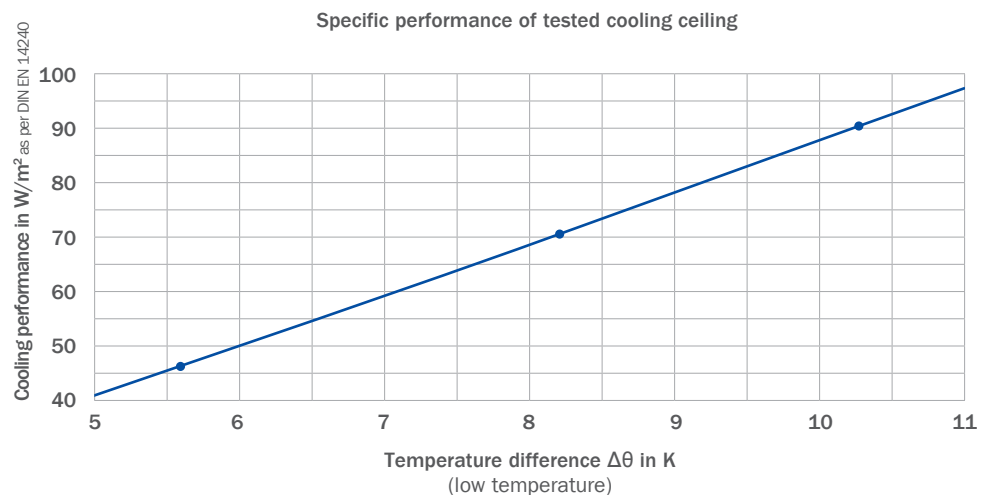

Please contact us if you require more performance values of our system (e. g. calculations of heating performance).

The performance description of the cooling and heating ceiling refers to 60 % radiation and 40 % convection. What does that mean with respect to the finished object?

The radiation proportion of a cooling ceiling is ideally approx. 60 %. The remaining proportion of 40 % is performed by means of free convection. In this process, the air warmed up by the heat sources rises, i.e. natural buoyancy causes the developed heat not dissipated due to radiation exchange to flow below the ceiling. This is why we generally recommend an open shadow gap of approx. 20 mm for cooling ceilings. The warmed-up air is cooled there and falls back diffusely, mixed with room air, into the occupied zone.

What is the minimum structural height that has to be considered in the design process for installing a cooling and heating ceiling?

At least 65 mm overall height must be available for the installation. But experience has shown that a structural height of 150 to 200 mm is recommendable due to the installation of lighting, safety and other services equipment as well as access for inspection.

Is a cooling and heating ceiling sufficient for fully air-conditioning a room?

Cooling and heating ceilings contribute essentially to the air-conditioning of modern buildings in an energy-efficient manner. But depending on the project, it may be necessary to combine them with a ventilation system and/or additional cooling and heating surfaces. For this reason, specialist engineers have to be involved in the detailed planning to achieve the best possible result for the end user.

Does the effect of the acoustic ceiling / acoustic plaster ceiling in terms of sound absorption remain unchanged despite the cooling and heating system installed on its back?

The cooling and heating system installed behind the acoustic ceiling (heat conducting profiles resting on the panel and reducing the effect of the acoustic fleece) does have a negative impact on the acoustic performance of the ceiling. We have, therefore, commissioned both TÜV Rheinland and LGA Products GmbH Nürnberg to conduct several echo chamber measurements with and without heat conducting profiles in order to determine the deviation. The result of the tests was that the acoustic performance of the ceiling is reduced by an average of approx. 15-20 %.

Does the cooling and heating system at the back of the panel pose an increased risk of cracking?

There is no increased risk of cracking if our manufacturer's instructions for the installation of framework and panels are observed (e.g. expansion joints, see p. 5). However, we generally recommend our tested complete systems from Vog| Deckensysteme.

What building material class does the finished cooling and heating ceiling system fulfil?

Framework and cooling system can be classified as material class A1 in accordance with the EN standards. The acoustic design / Thermotec panels below fulfil material class A2,s1,d0 as per EN 13501.



VoglThermotop® System

Plasterboard cooling and heating ceiling system VoglThermotop®, for the dissipation of thermal loads through radiation by approx. 60 % and through convection by 40 %. Cooling and heating coils are hooked in between the CD secondary profiles using special GKH system suspenders; rigid framework of galvanised metal profiles is hung with horizontally and vertically aligned suspended brackets and installed using materials and fixtures approved by the relevant building authorities, all in compliance with the manufacturer's instructions.

System structure

Framework in accordance with DIN 18181:2007-02

Profiles:

Pressure-resistant design made from galvanised sheet steel profiles CD 60/27 as primary and secondary profiles in accordance with EN 14195

Suspended brackets:

- Suspended brackets with vernier systems (top, vernier hanger),*
- Suspended brackets with vernier systems (top, base),*
- Suspended brackets with direct suspended brackets,*
- Use fixing materials approved by the relevant building authorities.

Connection:

Use cross connectors for primary-secondary profile connection, suspended brackets and cross connectors in accordance with EN 13964,

suspended bracket centre distance: max. 900 mm,
primary profile centre distance: max. 1100 mm,
secondary profile centre distance: _____ mm.*
(depending on panel type)

Cooling and heating system:

Cooling and heating system in accordance with RiLO processing instructions and technical documentation.

Cooling and heating coils are hooked in between the CD secondary profiles using GKH system suspenders. The cooling system thus hangs approx. 3 cm below the bottom edge of the secondary profile.

This results in a homogeneous, heat-conducting contact between the RiLO system and the plasterboard panel.

Design of coil: type CU50-GK* / type CU65-GK*
Design of copper tube: 10 mm* / 12 mm*

Technical data:

- Cooling performance active as per EN 14240:W/m²
- Room temperature: _____ °C
- Cooling water supply: _____ °C
- Cooling water return: _____ °C
- Designed cooling performance with regard to the active surface as per EN 14240: W/m²
- Heating performance as per VDI 4706: _____ W/m²
- Room temperature: _____ °C
- Hot water supply: _____ °C
- Hot water return: _____ °C
- Designed heating performance with regard to the active surface as per EN 14240: _____ W/m²

Follow-up services:

- Covering with Vogl Thermotec panels*

Complete system: Vogl Deckensysteme, or equivalent

* Delete as applicable



VOGL System Training

Our know-how for your
result reliability



Topic:

Acoustic plaster system VoglToptec® – Applications and processing

Description

Acoustic plaster ceilings provide homogeneous surfaces and numerous possibilities for designing high-end ceilings. Thanks to the multiple system variations (e.g. in conjunction with climate control ceilings) and the complete assortment of accessories "from one source", the VoglToptec system offers unique application and result reliability. In addition to theoretical fundamentals, our system training offers mainly practical guidelines for the installation work on site.

Topics

- Various systems and special panel types (e.g. Thermotec panels)
- Panel arrangement and sensible space division for the installation
- Correct assembly and adjustment of panel joint areas
- Frequent wall connections and how to execute them properly
- Expansion joints in the ceiling area/ regulations and recommendations
- Integrated ceiling components – fundamentals and problems
- Technical equipment required for reliable workmanship
- Coating work (priming, wallpapering, acoustic plaster)
- How to avoid typical processing errors in acoustic plaster ceilings

Targets

After completion of the seminar, the system training participants shall

- Understand and be able to apply the current standards and regulations
- Recognise and avoid the typical installation errors
- Be able to perform the installation and coating of acoustic plaster ceilings

Target group

This system training is equally suited for site and project managers as well as for drywall installers and interior construction workers. Likewise, for painting contractors whose work includes "acoustic plaster coating". Also, technically adept employees in sales or from the building material dealers' can extend their knowledge about the proper installation of ceiling structures.



A registration form is available on page 176. You have any questions in advance? We are glad to assist you! Phone: 09104-825-100

Registration is possible by e-mailing sauchella@vogl-deckensysteme.de directly or by fax to 09104/825-280. You can also find all information on training under www.vogl-ceilingssystems.com



Curved Ceilings *in Any Shape or Form*

Delivered to the site in perfect shape

Available V-grooves

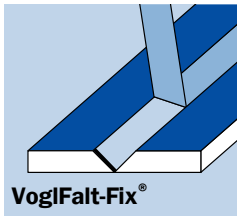

Fold Fix moulded components come flat (space-saving) and factory-supplied with Fold Fix adhesive tape.

VogIFalt-Fix®

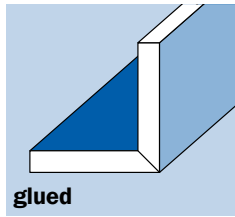

glued

Special glued moulded components come ready to install.

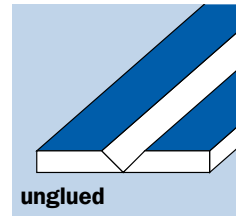

unglued

Special unglued moulded components come flat and must be assembled and glued on site.

Available angles

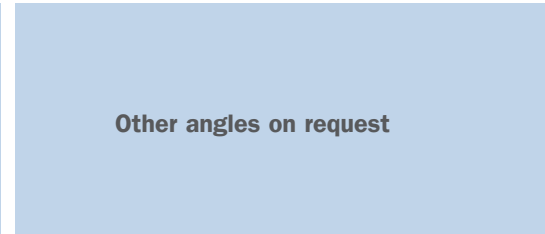
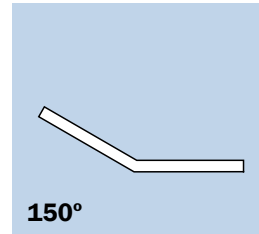
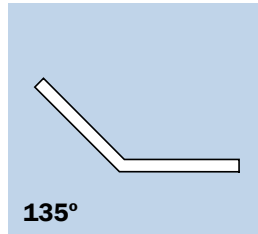
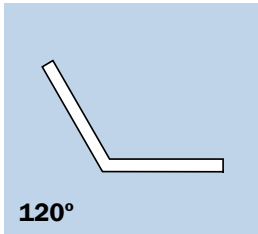
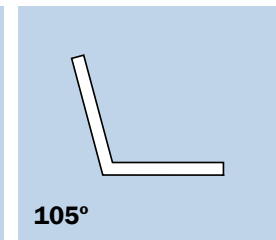
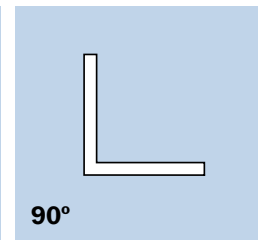
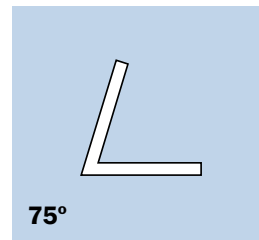
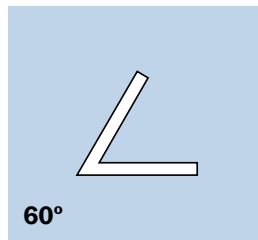
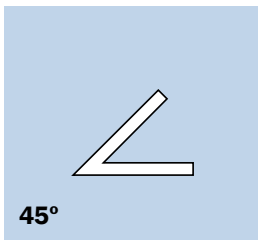

Available edge designs (subject to technical feasibility)

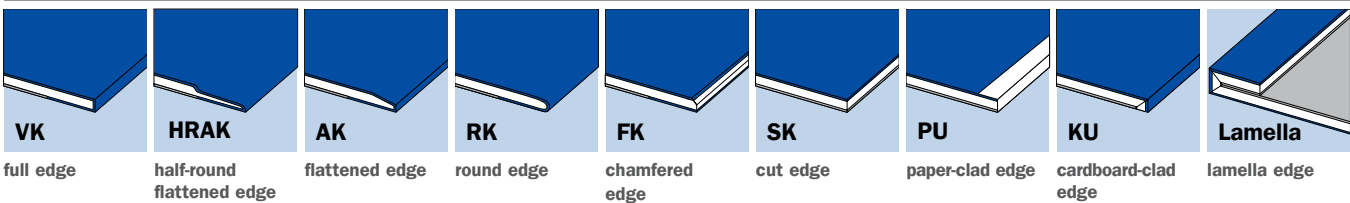

Available panel designs/thicknesses

Type	Description	Function	Thickness in mm
A	Plasterboard type A as per EN 520 Plasterboard type GKB as per DIN 18180	Standard plasterboard Note: available as Thermotec in 10 mm thickness	6.5 mm 9.5 mm 10.0 mm 12.5 mm
DF	Plasterboard type DF as per EN 520 Plasterboard type GKF as per DIN 18180	Plasterboards with improved fire behaviour	12.5 mm 15.0 mm 18.0 mm 20.0 mm 25.0 mm
DFH2	Plasterboard type DFH2 as per EN 520 Plasterboard type GKFI as per DIN 18180	Plasterboards with reduced water absorption (impregnated)	12.5 mm 15.0 mm 20.0 mm 25.0 mm

Illustration	Item number	Description	Dimensions width length thickness	m ² /pallet pcs./pallet
		Fold Fix moulded components Plasterboards cut to size with 90° V-grooves and Vogl Falt-Fix® adhesive tape	Type of panel Type "A" (EN 520) Custom dimensions and other panel types available on request	
<p>Voglfalt-Fix®</p>	75700010	Fold Fix moulded components 90° 100+200	300 x 2000 x 12.5 mm	400 m/pallet 200 pcs./pallet
	75710010	Fold Fix moulded components 90° 200+200	400 x 2000 x 12.5 mm	300 m/pallet 150 pcs./pallet
	75720010	Fold Fix moulded components 90° 300+300	600 x 2000 x 12.5 mm	200 m/pallet 100 pcs./pallet
	75730010	Fold Fix moulded components 90° 200+400	600 x 2000 x 12.5 mm	200 m/pallet 100 pcs./pallet
<p>1. Delivered flat</p>	<p>2. Remove cover paper</p>	<p>3. Press limbs firmly together</p>	<p>4. Done!</p>	
<p>Key advantages:</p> <ul style="list-style-type: none"> • Glueless joining of moulded components on site, no priming, no drying times • Easy on-site handling of moulded components • High adhesive strength immediately • Angle adjustment of ± 2° after adhesion • Delivered flat - less handling damage 		<p>Note:</p> <p>Fold Fix moulded components must be installed without any stresses acting upon them. The free limb must be fixated.</p>		
		GK panel strips Glued plasterboards as moving ceiling connection Long edge: SK Short edge: SK	Type of panel Type "A" (EN 520) Custom dimensions available on request	
	76000070	Panel strips (double)	50 x 2500 x 25.0 mm	1,260 m/pallet 504 pcs./pallet
	76010070	Panel strips (double)	75 x 2500 x 25.0 mm	880 m/pallet 352 pcs./pallet
	76020070	Panel strips (double)	100 x 2500 x 25.0 mm	690 m/pallet 276 pcs./pallet
	76100070	Panel strips (triple)	50 x 2500 x 37.5 mm	840 m/pallet 336 pcs./pallet
	76110070	Panel strips (triple)	75 x 2500 x 37.5 mm	560 m/pallet 224 pcs./pallet
	76120070	Panel strips (triple)	100 x 2500 x 37.5 mm	450 m/pallet 180 pcs./pallet
	76200070	Panel strips (quadruple)	50 x 2500 x 50.0 mm	600 m/pallet 240 pcs./pallet
	76210070	Panel strips (quadruple)	75 x 2500 x 50.0 mm	440 m/pallet 176 pcs./pallet
	76220070	Panel strips (quadruple)	100 x 2500 x 50.0 mm	330 m/pallet 132 pcs./pallet

Illustration	Item number	Description	Dimensions width length thickness	m/pallet pcs./pallet
		Microslits (longitudinal slits) of type "A" plasterboards (EN 520) 12.5 mm for on-site adaptation to round components with tight radii		ME = 1 m
	74807020	Microslits (longitudinal slits)	1250 x 2000 x 12.5 mm	Packed in bulk according to required quantity
	74817020	Microslits (longitudinal slits) Plaster strip: 5.0 mm Groove: 1.7 mm For radii \geq 80.0 mm	600 x 2000 x 12.5 mm	

Other thicknesses, lengths and qualities on request. Longitudinal, unslit edge to the left and/or right possible on request. Custom elements possible.

Quarter shells

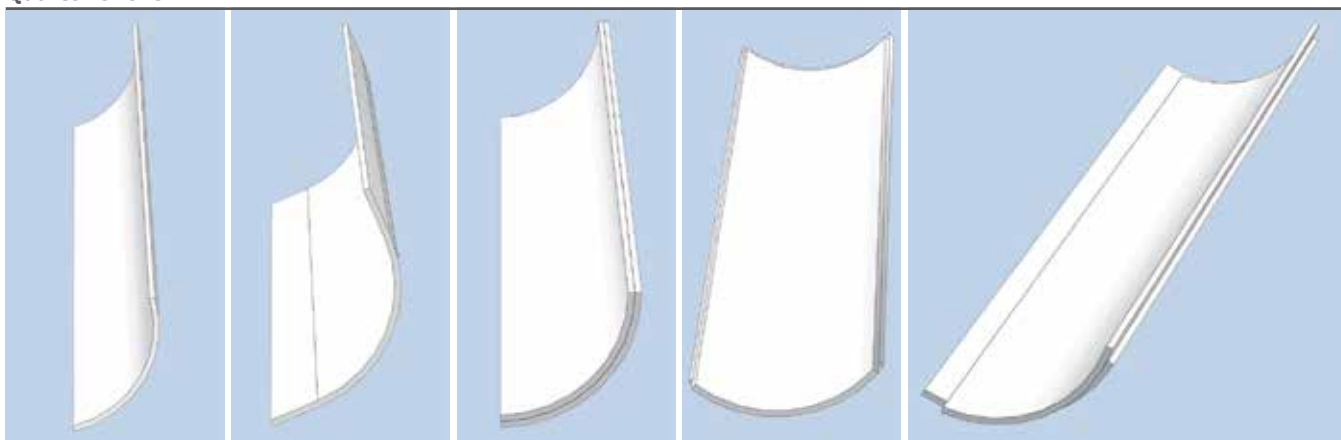

Half shells

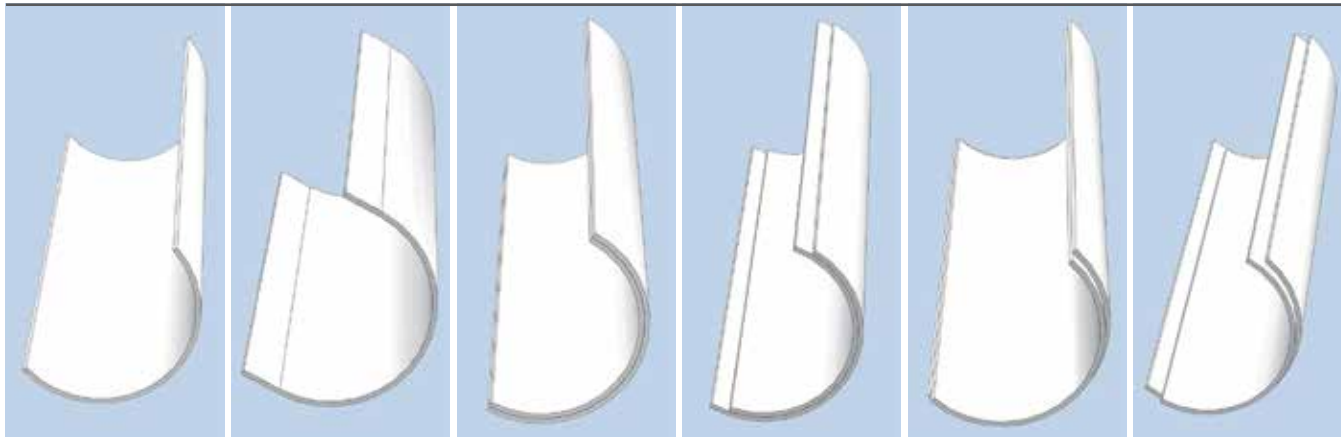

Moulded Components,
3D Design

3D Design

The easiest way to get curved ceilings into good shape

Three-dimensional ceiling designs with curved components are the royal class in sophisticated interior design.

Various types of arches, domes or curved segments as well as convex or concave forms require a high level of craftsmanship. Vogl Deckensysteme achieves the basis for the complex interaction between individual steel and plaster components through comprehensive expertise and absolute precision in detail.

To be best in class, all resources must interact like clockwork. This principle in daily business practice makes us market leader in the royal class Vogl3D Design. 3D projects are our specialty, from initial consultation to final installation.

Absolute precision already pre-fabricated:

- High dimensional accuracy of all individual parts guarantees highly aesthetic final results
- Complex two- and three dimensional shapes can be produced
- Economical installation provides an important time advantage and result reliability
- Manageable units for optimal logistics and handling on the job site
- Sophisticated problem solvers out of prefabrication – Vogl Fold Fix
- Our knowledge of the manifold options of applications is the key to success, starting right at the initial planning stage
- Customised special solutions from lightweight steel construction to individual covering are realised in short time

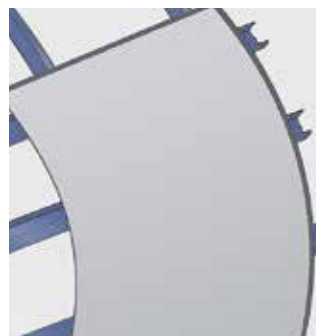

Advantages of Vogl3D moulded components:

- Consistent shapes, perfect radii – component by component
- Almost no finishing and follow up work required
- Economical and clean way of working
- Elegant, practicable system solutions for frameworks
- High level of prefabrication = rational job site handling





Access Panels



Quick Access
Whenever Needed

Perfect integration married with functional handling

Quick access, homogenous design

Acoustic ceilings usually have more than one function. The space in the ceiling void must often be used for technical installations such as light, climate control, sound and fire protection systems.

Access panels are essential to keep these installations accessible for maintenance and repair even after the suspended ceiling has been installed.

Vogl Access Panels offer top performance for easy access while fulfilling all aesthetic requirements at the same time.



The advantages of the access panels in detail:

- Available in 10.0/12.5/15.0 mm thickness for various applications
- Sturdy, high-quality aluminium frame for dimensional stability
- Multiple perforation patterns available ex factory
- Consistency in the rows of perforation throughout the ceiling
- Backed with acoustic fleece for high acoustic performance
- Sturdy catch mechanism (for panels > 300 mm) keeps the lid from falling down while being opened
- Customised special designs can be produced



The standard catch mechanism (for access panels > 300 mm) prevents the access panel lid from falling out accidentally while being opened. For work in the ceiling void, the lid can be conveniently detached and removed.

The factory-integrated perforated panel lid ensures a homogeneous integration into the ceiling surface with a frieze area that is not or only minimally non-perforated, depending on the perforation pattern. (Exception: random perforation panels should always be fitted into place at the job site)

Mark intended position of access panels on ceiling, considering that cutout has to be 4 mm larger than clear passage size. Cut out marked section. Make sure there are no panel joints within area of cutout.

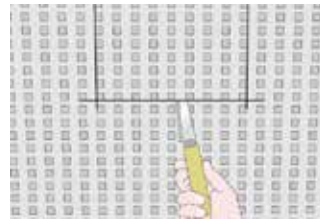
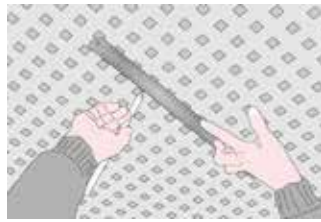

Note:

- Install trimmers of CD profiles in accordance with dimensions of access panel
- Observe distances between cutout and trimmer of min. 30 mm and max. 50 mm
- Mount 4 additional suspended brackets in corner areas of access panels
- It may be necessary to include additional suspended brackets so as not to exceed maximum bracket spacing

The best way to achieve the accurate dimensions of the cutout is to use a plasterboard plane and/or sandpaper/abrasive mesh for the precision work.

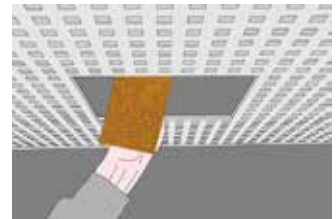
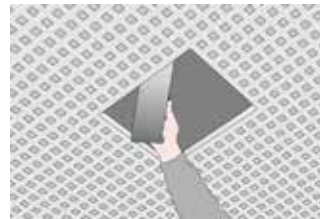
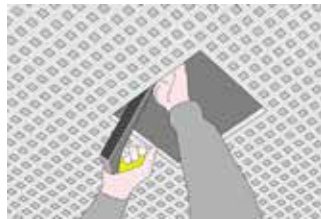

Then chamfer the visible side of the acoustic design panel slightly to facilitate the filling of joints later on. Then insert the frame of the access panel and hold it in place by means of a mounting aid matching the perforation pattern.

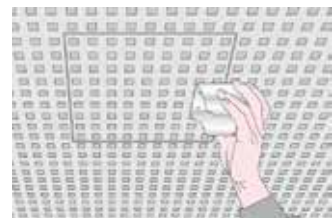

Predrill access panel frame with metal drill and fasten it with perforated panel screws SN.



Be sure to use at least 2 screws per frame side for panel size < 500 x 500 mm and at least 3 screws per frame side for panel size > 500 x 500 mm

Then insert the lid and check the closing function. Cover the row of perforation directly adjacent to the access panel with masking tape.



Now apply filling compound to the access opening, remove the masking tape right afterwards and knock away any excess filler to make it flush with the ceiling surface. Observe the relevant filler manufacturer's instructions.

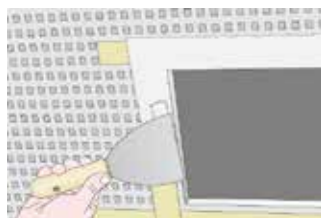

After filler has dried, sand any edges or protruding material.



Note:

- Our "Painting Instructions" are applicable for final coating
- Take out access panel lid and paint it separately to prevent paint from getting into narrow joint between frame and lid
- Clean outer and inner frame thoroughly after coating
- Exception: With acoustic plaster ceilings, lid should remain in ceiling surface in order to obtain uniform spray pattern. In this case, make sure to clean joint between frame and lid after every spray application.

VoglModu® QuadRound

Light to the site – ready to go

The creation of light strategies used to be a highly individual job for specialists.

With the modular illumination system VoglModu® QuadRound, the industry receives prefabricated light modules for the first time which offer new design possibilities and simplify installation tremendously. Whether for integration in suspended ceilings or as tailored illumination modules for floating ceilings.

They offer diversity and multi-purpose use. The round or square design of the illumination modules harmonise ideally with the respective perforation patterns of the perforated panel ceilings. VoglModu® QuadRound is equally suitable as a functional eye catcher for the design of smooth or plastered surfaces, whether wall or ceiling.

The modular illumination system ready for installation:

- The fantastic effects of a light module with unexpected ease of installation
- Prefabricated modules for simple wall and ceiling installation
- For integration in suspended perforated ceilings, plaster ceilings and smooth ceilings or as integration in floating ceilings to complement existing surfaces
- Perfectly flush and levelled perimeters in the finished areas
- Available in various types of shape, format and technical equipment
- Apart from the standard design, a dimmable or a DALI-compatible design with colour combinations is available
- Innovative colour design is achieved by simply covering the fluorescent lamps with coloured foils



Prefabricated for delivery to the job site:

The light module is installed into the ceiling structure accurately fitting, which results in perfectly flush and levelled perimeters in the finished areas.

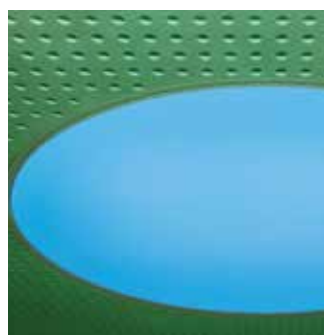

Illumination in just a few steps:

After connection to the building services and fitting of the fluorescent tubes, the frame which is already covered with a matt foil can be installed – done!

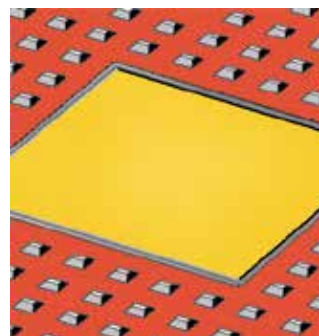

Advantages of VoglModu® QuadRound:

- Fits in perfectly with the ceiling appearance
- Perfectly easy to install in suspended ceiling or to integrate into prefabricated floating ceilings
- No special skills required
- Install large-area and coloured lighting
- As fast as lightning
- Can be used as a "stand-alone" light module

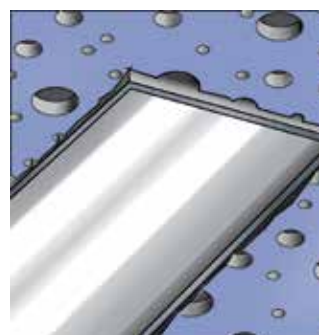

Disadvantages of conventional ceiling lighting:

- No homogenous integration into the existing ceiling design
- Makeshift installation solutions
- Very limited illumination performance

Vogl Stretch Ceiling

Impressive play between form, colour and light

The spectrum of design possibilities has been significantly expanded with acoustic design ceilings. The elegant integration of stretch ceiling surfaces in acoustic design ceilings makes for a striking aesthetic appearance using colour, light and degrees of gloss, and, in its function as an illuminated ceiling, provides a gentle surface lighting with variable colour mix. The superb diversity of both colours and shapes is impressive!

Clear geometric surfaces or freely defined shapes, combining various perforation patterns of the acoustic design panels, result in ceiling areas which are rich in contrast and can be level or stepped for 3D accentuation. In addition, Vogl's renowned economical, quick and reliable processing provides confidence in the final product.

Vogl Stretch Ceilings offer almost unlimited design freedom with:

- Exciting surfaces and three-dimensional shapes
- Contrasts between colours and degrees of gloss
- Accentuated interaction of light and illumination
- More corporate design by using printed foils
- Ideal combination options with acoustic design ceilings in form, colour and performance

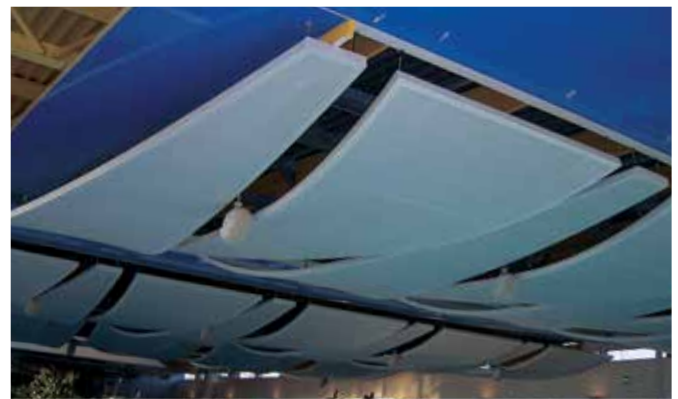

Great when renovating:

- Minimal production and business down times
- No generation of dust and moisture
- Buildings generally remain operable
- No removal and disposal of existing ceilings
- No expensive new installations

Great in wet and humid areas:

- Suitable for spa areas through foil colours or colour-controlled illuminated ceilings
- Completely moisture-resistant foils and profiles
- Splash protection for ceiling installations such as light and sound systems
- Reduction of the reverb time





Vogl Double Layer Fleece

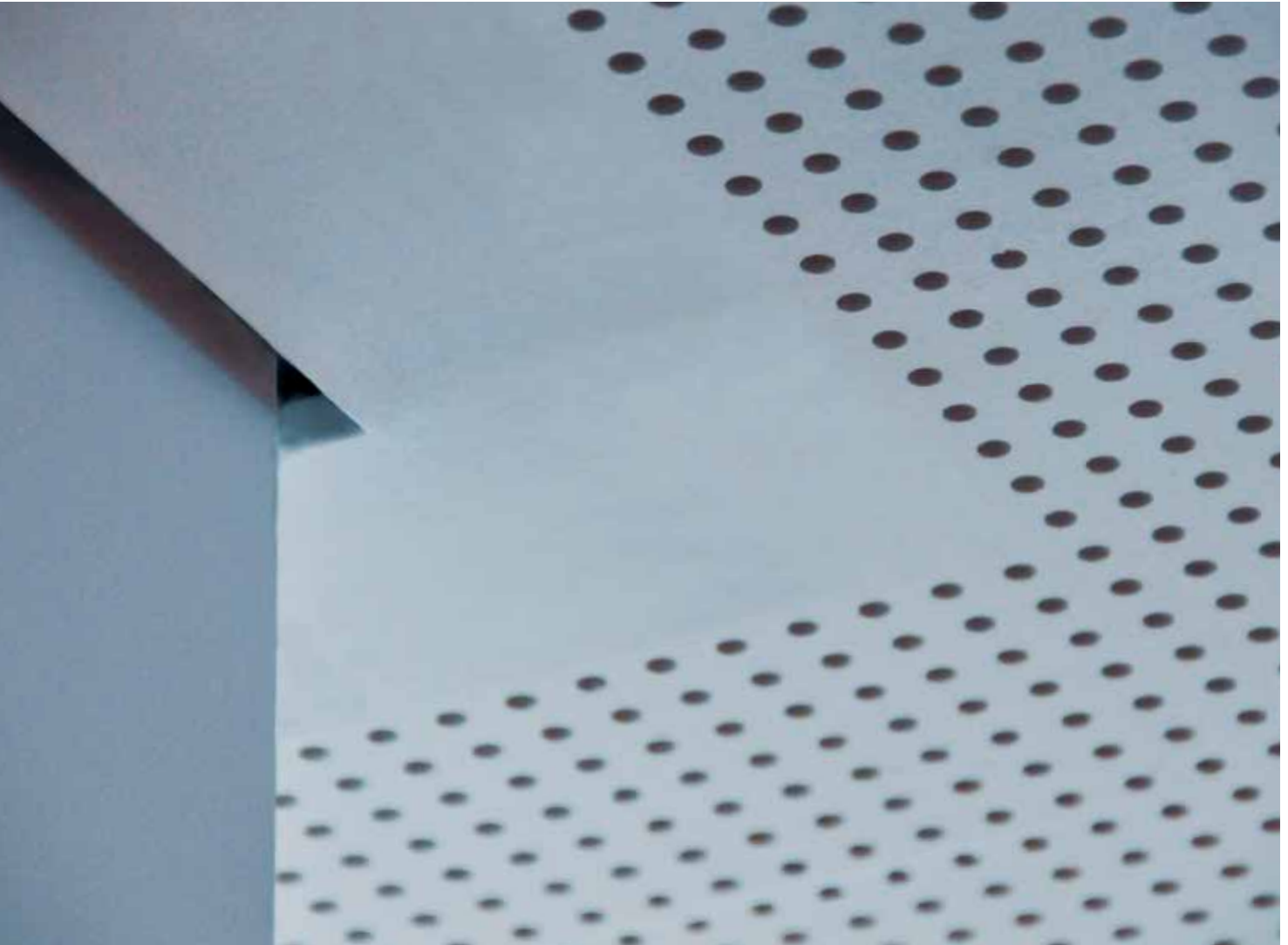

On One Level
in Spite of Differences

The multitalent for your acoustic design ceiling

Evenness easier than ever

This is what drywall construction has waited for: Evenness between perforated and smooth gypsum boards used to be achieved by tedious spackling.

This required a tremendous effort to equalize the small difference in height caused by the fleece laminated on the back of the perforated panels.

The idea behind the ultra-fast levelling solution is ingeniously simple: Vogl Double Layer Fleece, which is self-adhesive and comes on rolls ready for use, makes the levelling of height differences easier than ever.

Brilliantly simple realisation of shadow gaps in contrasting colour for the perfectly designed ceiling. Optically appealing design of expansion joints by backing them in black or white.

Benefits of the Vogl Double Layer Fleece system:

- Faster and more economical installation due to self-adhesive rolled material
- Tedious, time-consuming spackling is now a thing of the past
- Practical helper for many transition and connection issues
- Homogeneous material for perfect connection to fleece-laminated perforated panels
- Available in various tape widths for single or double application
- Available in white or black fleece colour



Expansion joints

For the coloured design of expansion joints in the ceiling.

Your advantages when using Vogl Double Layer Fleece:

- Clean workmanship (no need to use a brush)
- Available in black or white
- Tape on rolls is applied quickly and easily

Panel connections

Flush panel connections between perforated panels and smooth plasterboards.

Your advantages when using Vogl Double Layer Fleece:

- Quick installation with self-adhesive roll material
- No filling work – connection between perforated panels and smooth plasterboards possible with Vogl Frieze Tape 20 mm
- Available in various tape widths
- Single-layer or multi-layer application possible (depending on height difference)

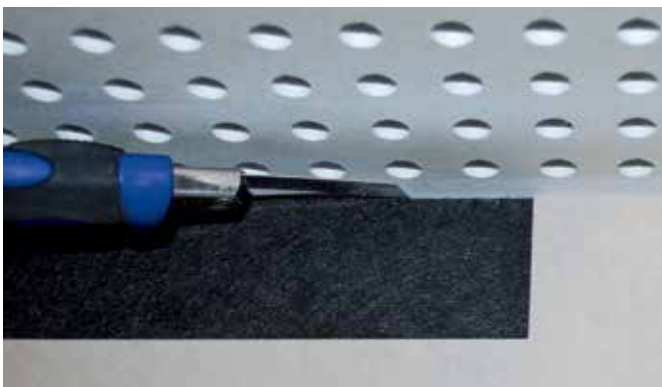

Wall connections

Perfect wall connections in various designs. Whether as filled joint or as wall connection with shadow gap.

Your advantages when using Vogl Double Layer Fleece:

- Functions as separating tape for a filled joint
- Colour of shadow gap available in white or black
- One product only for a variety of joint and connection applications

Vogl Double Layer Fleece		
Article no.	Article description	Dimensions
90310000	Double Layer Fleece VAD 32 black Self-adhesive fleece, black	Roll width 32 mm Roll length 200 m
90320000	Double Layer Fleece VAD 62 black Self-adhesive fleece, black	Roll width 62 mm Roll length 200 m
90311000	Double Layer Fleece VAD 32 white Self-adhesive fleece, white	Roll width 32 mm Roll length 200 m
90321000	Double Layer Fleece VAD 62 white Self-adhesive fleece, white	Roll width 62 mm Roll length 200 m

Extra: non-perforated frieze area, frieze areas w = _____ mm of smooth plasterboards

Creating frieze areas of smooth plasterboards, th = 12.5 mm, transition from frieze area to perforated panel ceiling made with Vogl Double Layer Fleece (height compensation) and Vogl Frieze Tape 20 mm. Installation in accordance with manufacturer's instructions.

Extra: wall connection, with coloured shadow gap

Wall connection by means of a shadow gap (approx. 15 - 20 mm), coloured in black*/white* using Vogl Double Layer Fleece in accordance with manufacturer's instructions.

Extra: expansion joint for ceiling structure

Integrating expansion joints in aforementioned ceiling system. In this area, the framework must be completely separated from the rest. The expansion joint shall be backed with a strip of plasterboard coloured with Vogl Double Layer Fleece in black*/white*. The backing strip of plasterboard shall be screwed down on one side only. Width of joint > 5 mm. Insert edge protection profile, if required.

Extra: wall connection, with filled joint

Wall connection by means of filled joint using Vogl Double Layer Fleece as separating tape in accordance with manufacturer's instructions.

* Delete as applicable

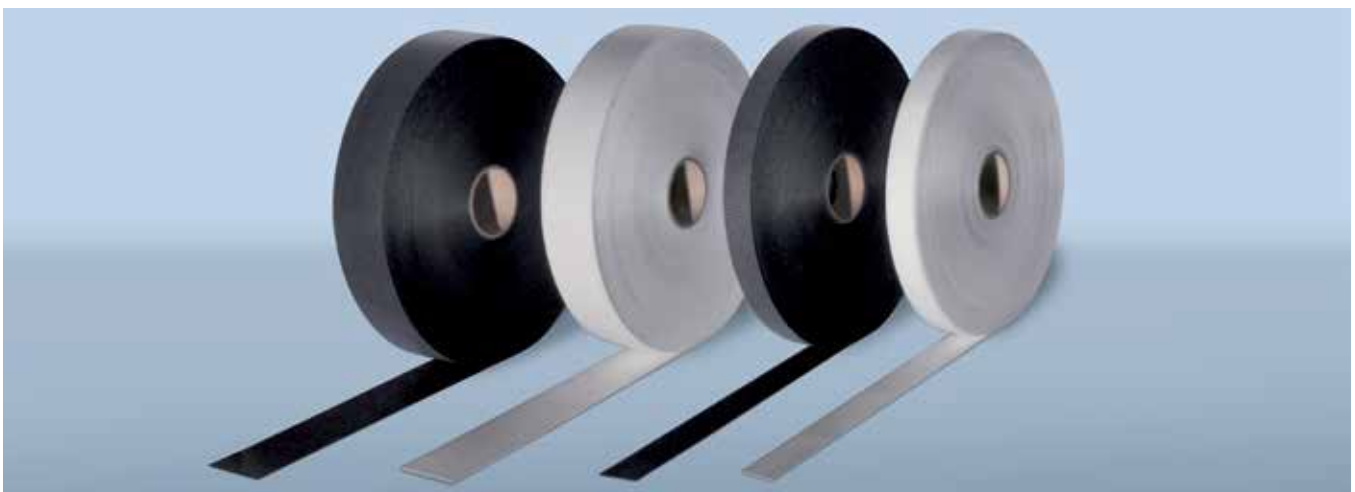



VoglFriestape-Set®



Perfect Borders

Straight from the Roll

Perfectly simple frieze solutions

Ceiling friezes in record time

There are various ways of creating plain borders and perimeters for perforated plasterboard ceilings. However, these typically require intensive preplanning and tedious time consuming work on site. Now there is an efficient, clean and safe solution: the VoglFriestape-Set®. With this method, non-perforated frieze areas can be produced quickly and economically, saving a great deal of time and hassle. The frieze tape set includes all accessories needed at the job site for making a frieze of any width. Just a few simple steps can produce a neat perimeter or border.

Advantages of the VoglFriestape-Set® system:

The unique workmanship provides key advantages when creating non-perforated frieze areas:

- Quick, safe and clean workmanship
- No generation of dirt and dust
- Active sound absorption even within the joint area
- Holes can be re-opened if required
- Filler cannot sink in, nor holes re-emerge



The VoglFriestape-Set® includes the required material, tools and a detailed assembly instruction to ensure top quality workmanship and reliable results.

The right tools at the right time in exactly the right place.

Check cardboard area; sand panel joints and screw holes.

Important! Failure to observe this may cause holes to show!

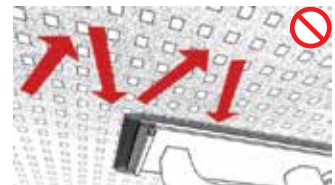
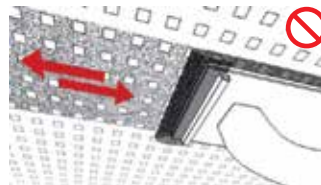
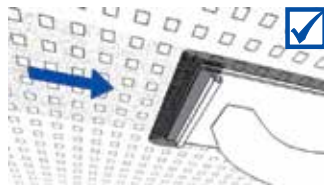

After sanding, wipe joint area with damp sponge to remove any dust or swarf.

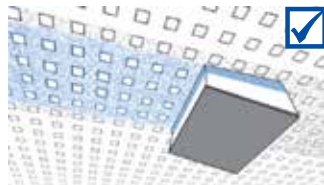

Load lambskin roller with liquid glue and roll it downward over paint grid.

Vogl Liquid Glue = ready-mix



General site conditions/Manufacturer's instructions:

- Always store liquid glue in ** frost free environment **
- Close liquid glue containers securely during long breaks
- Stir liquid glue well before use!
- Working temperature should be at least +10 °C and job site temperature not below +5 °C
- Avoid sudden heating and cooling of rooms
- Relative humidity: 40 - 80 %
- Self-levelling, cement or asphalt screeds must be fully dried – no residual moisture
- Apply tape only edge to edge, i.e. no overlapping
- Use liquid glue only undiluted

Roll liquid glue onto frieze area, then apply tape (making sure perforation is completely covered) and press it down with lambskin roller. Once tape has dried, open any half-open holes and then close them with joint compound.

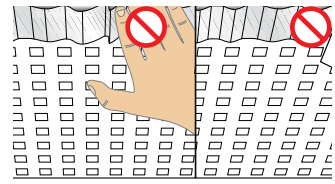
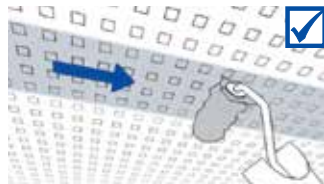

Different widths of tape can be combined without difficulty. However, make sure to lay tapes edge to edge. Under no circumstances should tapes be overlapped!

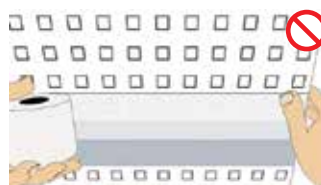

Re-load lambskin roller with liquid glue and roll it downwards over paint grid.

Vogl Liquid Glue = ready-mix



Surface treatment by painters

(in accordance with ATV (General technical specifications in construction contracts) DIN 18363, Painting and Coating Work)

- Only apply coating by roller; spray application is not permitted!
- Prior to application of paint coat, a primer should generally be applied in accordance with manufacturer's specifications
- Manufacturer's recommended drying times for both primer and finishing coat must be strictly adhered to
- Alkaline coatings are unsuitable for plasterboards
- 3 coats of paint must be applied (1 prime coat + 2 finishing coats), and recommended drying times adhered to
- Always consult system manufacturer's technical data sheets for primers and finishing coats

Apply another coat of liquid glue on frieze area, always working "wet on wet".

System's drying time: min. 12 hrs



If necessary (when dry), smooth glue texture on tape's visible surface by gently sanding in direction of joint – do not cross sand!

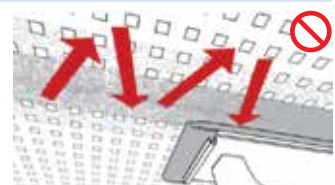
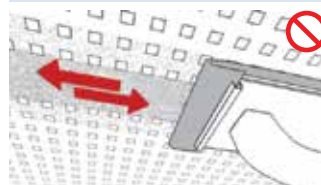
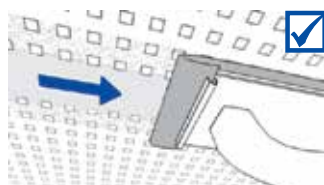

Once fully dry, any covered holes can be re-opened any time using a box cutter.



Scope of delivery, VoglFriestape®-Set:

Vogl liquid glue, Vogl tape, stirring paddle, paint grid, lambskin roller, abrasive mesh, sanding paper, sponge.
 VoglFriestape® -Set is available in various tape widths (20 mm, 50 mm, 75 mm, 100 mm, 150 mm)

Note: VoglFriestape-Set® is only recommended for hole sizes up to max. 20 mm.

VoglFriestape-Set®		
Item number	Article description	Tape dimensions in linear metres
90005324	VoglFriestape-Set® 20 mm tape width 20 mm	2 rolls of tape 20 mm = 200 linm
90005325	VoglFriestape-Set® 50 mm tape width 50 mm	3 rolls of tape 50 mm = 150 linm
90005326	VoglFriestape-Set® 75 mm tape width 75 mm	2 rolls of tape 75 mm = 100 linm
90005327	VoglFriestape-Set® 100 mm tape width 100 mm	1 roll of tape 100 mm = 50 linm
90005328	VoglFriestape-Set® 150 mm tape width 150 mm	1 roll of tape 150 mm = 50 linm



Illustration shows article 90005325

Extra: creation of frieze area using Vogl Frieze Tape

For extra, creation of frieze area using Vogl Frieze Tape in System VoglFriestape-Set®, observe manufacturer's instructions.

Frieze width: _____ mm



Acoustics and Sound Absorption



Design and Acoustics *Brought into Harmony*

Sound Absorption Values

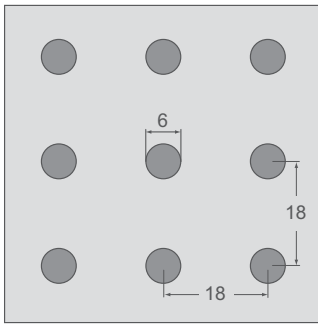

- Determination of sound absorption coefficient as per DIN EN ISO 354
- Rating of sound absorption coefficient as per DIN EN ISO 11654

Panel thickness: $th = 12.5 \text{ mm}$
 Mass per unit area: 9.10 kg/m^2
 Perforated area: 8.7%
 Material class as per DIN 4102: A2, "non-inflammable"
 Fire behaviour as per DIN EN 13501: A2-s1, d0

Back of panel laminated with
Acoustic fleece AV 2010

Rated sound absorption $\alpha_w = 0.55$
 sound absorption class **D**
 (absorbing)

Single number rating as per ASTM C 423:
 SAA = 0.51
 Classification as per ASTM E 1264:
 NRC = 0.50

Air gap: 200 mm

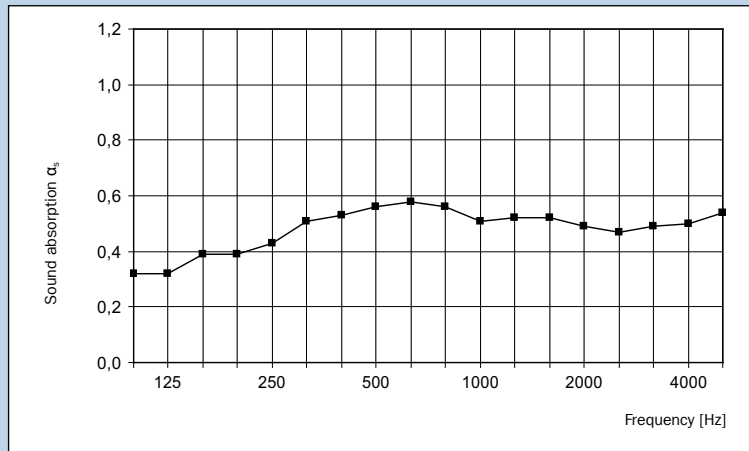

Octave centre frequency [Hz]	125	250	500	1000	2000	4000
Sound absorption coefficient α_s	0.32	0.43	0.56	0.51	0.49	0.50

Back of panel laminated with
Acoustic fleece AV 2010
 backed with glass wool
Mineral wool panel SSP 1, 30 mm

Rated sound absorption $\alpha_w = 0.55$
 sound absorption class **D**
 (absorbing)

Single number rating as per ASTM C 423:
 SAA = 0.53
 Classification as per ASTM E 1264:
 NRC = 0.55

Air gap: 200 mm

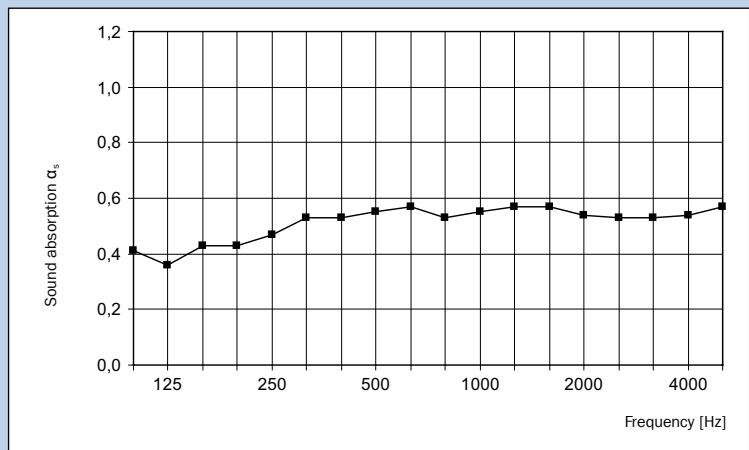

Octave centre frequency [Hz]	125	250	500	1000	2000	4000
Sound absorption coefficient α_s	0.36	0.47	0.55	0.55	0.54	0.54

Find all our product documentation in many languages, always up-to-date and available at any time, on our website under:
<http://www.vogl-ceilingssystems.com/> in the "Downloads" category

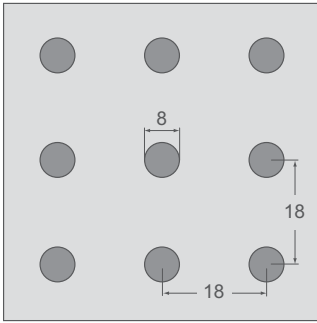

- Determination of sound absorption coefficient as per DIN EN ISO 354
- Rating of sound absorption coefficient as per DIN EN ISO 11654

Panel thickness: $th = 12.5 \text{ mm}$
 Mass per unit area: 8.50 kg/m^2
 Perforated area: 15.5%
 Material class as per DIN 4102: A2, "non-flammable"
 Fire behaviour as per DIN EN 13501: A2-s1, d0

Back of panel laminated with
Acoustic fleece AV 2010

Rated sound absorption $\alpha_w = 0.70$
 sound absorption class **C**
 (highly absorbing)

Single number rating as per ASTM C 423:
 SAA = 0.67
 Classification as per ASTM E 1264:
 NRC = 0.65

Air gap: 200 mm

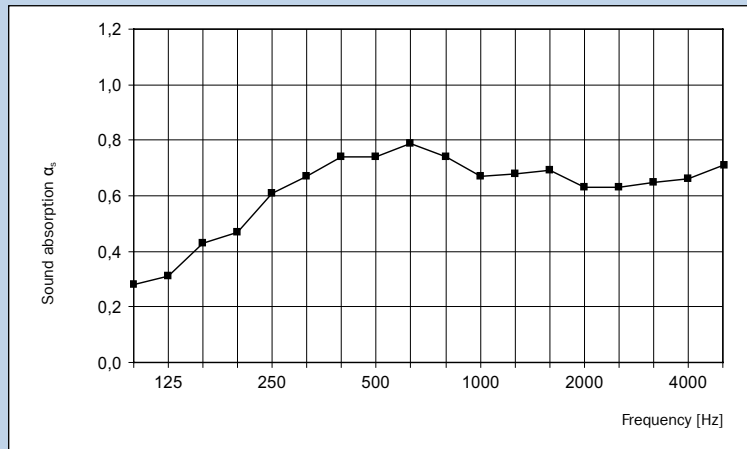

Octave centre frequency [Hz]	125	250	500	1000	2000	4000
Sound absorption coefficient α_s	0.31	0.61	0.74	0.67	0.63	0.66

Back of panel laminated with
Acoustic fleece AV 2010
 backed with glass wool
Mineral wool panel SSP 1, 30 mm

Rated sound absorption $\alpha_w = 0.75$
 sound absorption class **C**
 (highly absorbing)

Single number rating as per ASTM C 423:
 SAA = 0.72
 Classification as per ASTM E 1264:
 NRC = 0.70

Air gap: 200 mm

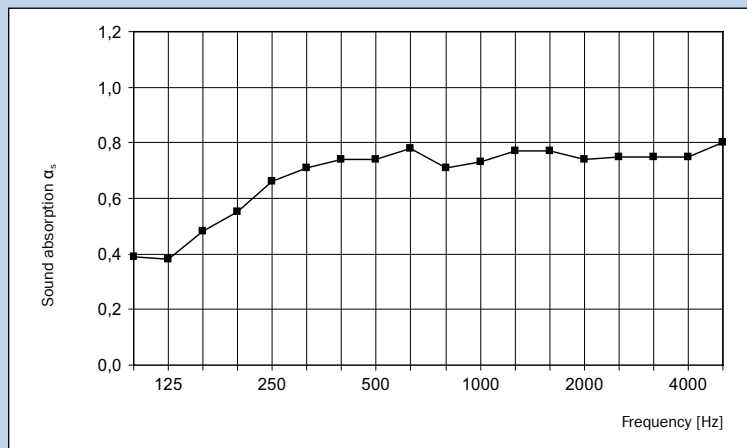

Octave centre frequency [Hz]	125	250	500	1000	2000	4000
Sound absorption coefficient α_s	0.38	0.66	0.74	0.73	0.74	0.75

Find all our product documentation in many languages, always up-to-date and available at any time, on our website under:
<http://www.vogl-ceilingssystems.com/> in the "Downloads" category

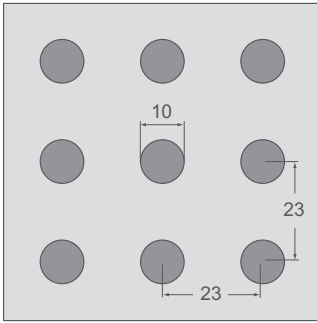

- Determination of sound absorption coefficient as per DIN EN ISO 354
- Rating of sound absorption coefficient as per DIN EN ISO 11654

Panel thickness: $th = 12.5 \text{ mm}$
 Mass per unit area: 8.50 kg/m^2
 Perforated area: 14.8%
 Material class as per DIN 4102: A2, "non-inflammable"
 Fire behaviour as per DIN EN 13501: A2-s1, d0

Back of panel laminated with
Acoustic fleece AV 2010

Rated sound absorption $\alpha_w = 0.70$
 sound absorption class **C**
 (highly absorbing)

Single number rating as per ASTM C 423:
 SAA = 0.65
 Classification as per ASTM E 1264:
 NRC = 0.65

Air gap: 200 mm

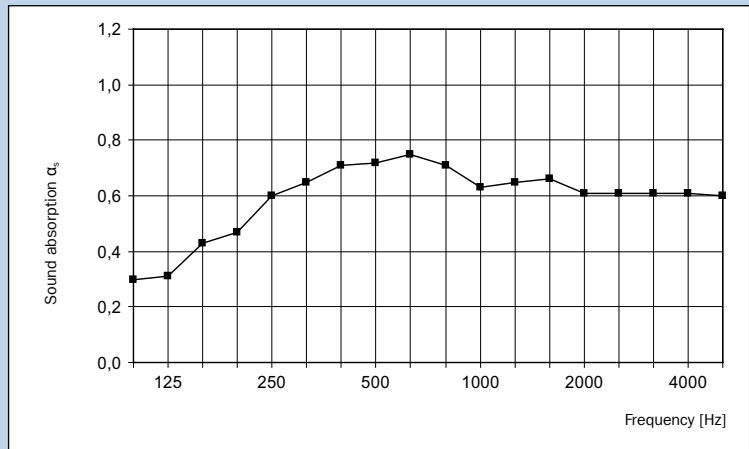

Octave centre frequency [Hz]	125	250	500	1000	2000	4000
Sound absorption coefficient α_s	0.31	0.60	0.72	0.63	0.61	0.61

Back of panel laminated with
Acoustic fleece AV 2010
 backed with glass wool
Mineral wool panel SSP 1, 30 mm

Rated sound absorption $\alpha_w = 0.70$
 sound absorption class **C**
 (highly absorbing)

Single number rating as per ASTM C 423:
 SAA = 0.69
 Classification as per ASTM E 1264:
 NRC = 0.70

Air gap: 200 mm

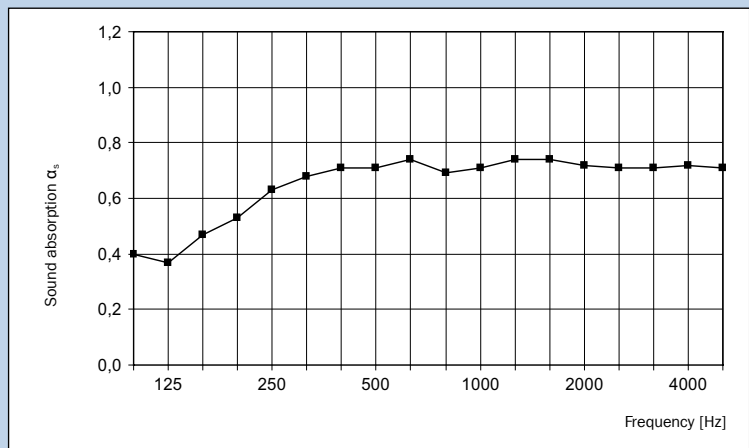

Octave centre frequency [Hz]	125	250	500	1000	2000	4000
Sound absorption coefficient α_s	0.37	0.63	0.71	0.71	0.72	0.72

Find all our product documentation in many languages, always up-to-date and available at any time, on our website under:
<http://www.vogl-ceilingssystems.com/> in the "Downloads" category

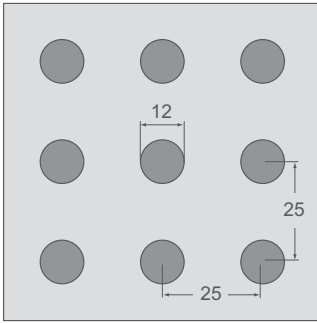

- Determination of sound absorption coefficient as per DIN EN ISO 354
- Rating of sound absorption coefficient as per DIN EN ISO 11654

Panel thickness: $th = 12.5 \text{ mm}$
 Mass per unit area: 8.20 kg/m^2
 Perforated area: 18.1%
 Material class as per DIN 4102: $A2, \text{ "non-inflammable"}$
 Fire behaviour as per DIN EN 13501: $A2-s1, d0$

Back of panel laminated with
Acoustic fleece AV 2010

Rated sound absorption $\alpha_w = 0.70$
 sound absorption class **C**
 (highly absorbing)

Single number rating as per ASTM C 423:
 SAA = 0.69
 Classification as per ASTM E 1264:
 NRC = 0.70

Air gap: 200 mm

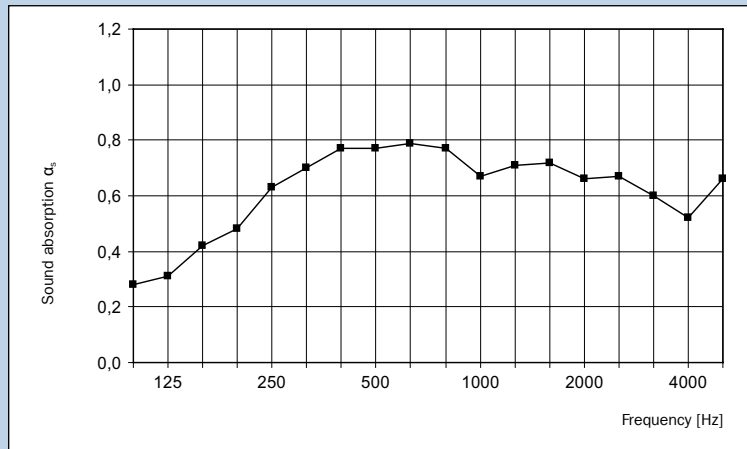

Octave centre frequency [Hz]	125	250	500	1000	2000	4000
Sound absorption coefficient α_s	0.31	0.63	0.77	0.67	0.66	0.52

Back of panel laminated with
Acoustic fleece AV 2010
 backed with glass wool
Mineral wool panel SSP 1, 30 mm

Rated sound absorption $\alpha_w = 0.80$
 sound absorption class **B**
 (extremely absorbing)

Single number rating as per ASTM C 423:
 SAA = 0.75
 Classification as per ASTM E 1264:
 NRC = 0.75

Air gap: 200 mm

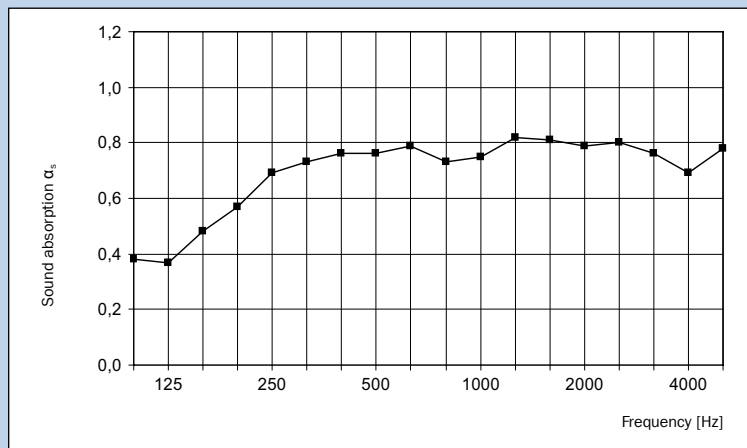

Octave centre frequency [Hz]	125	250	500	1000	2000	4000
Sound absorption coefficient α_s	0.37	0.69	0.76	0.75	0.79	0.69

Find all our product documentation in many languages, always up-to-date and available at any time, on our website under:
<http://www.vogl-ceilingssystems.com/> in the "Downloads" category

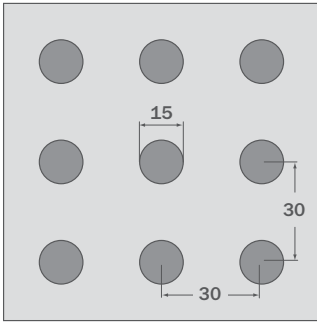

- Determination of sound absorption coefficient as per DIN EN ISO 354
- Rating of sound absorption coefficient as per DIN EN ISO 11654

Panel thickness: $th = 12.5 \text{ mm}$
 Mass per unit area: 8.00 kg/m^2
 Perforated area: 19.6%
 Material class as per DIN 4102: $A2, \text{ "non-inflammable"}$
 Fire behaviour as per DIN EN 13501: $A2-s1, d0$

Back of panel laminated with
Acoustic fleece AV 2010

Rated sound absorption $\alpha_w = 0.75$
 sound absorption class **C**
 (highly absorbing)

Single number rating as per ASTM C 423:
 $SAA = 0.69$
 Classification as per ASTM E 1264:
 $NRC = 0.70$

Air gap: 200 mm

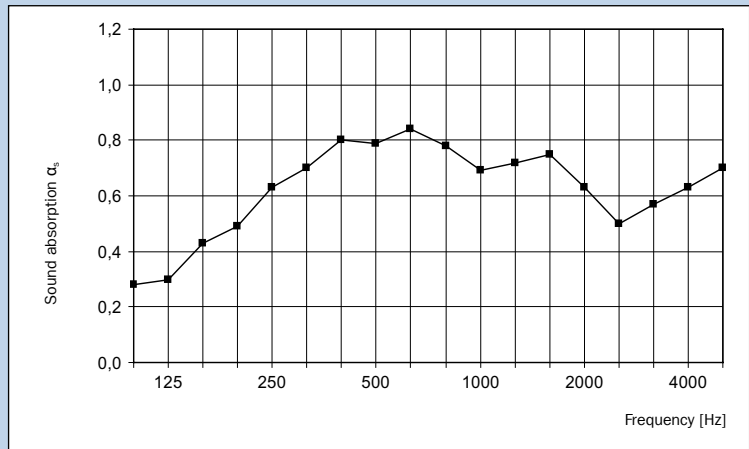

Octave centre frequency [Hz]	125	250	500	1000	2000	4000
Sound absorption coefficient α_s	0.30	0.63	0.79	0.69	0.63	0.63

Back of panel laminated with
Acoustic fleece AV 2010
 backed with glass wool
Mineral wool panel SSP 1, 30 mm

Rated sound absorption $\alpha_w = 0.80$
 sound absorption class **B**
 (extremely absorbing)

Single number rating as per ASTM C 423:
 $SAA = 0.77$
 Classification as per ASTM E 1264:
 $NRC = 0.75$

Air gap: 200 mm

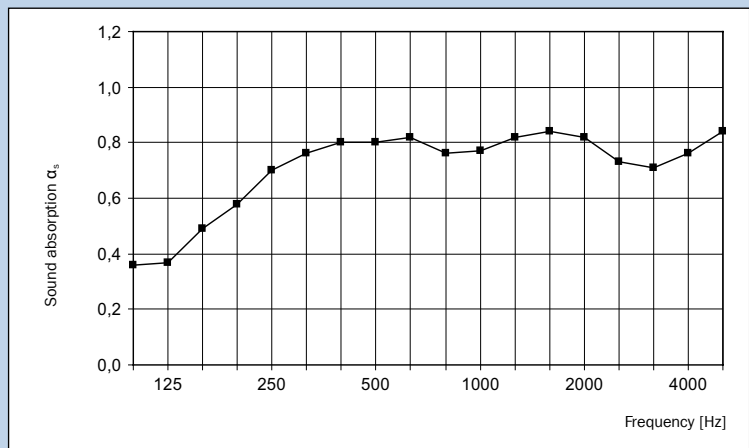

Octave centre frequency [Hz]	125	250	500	1000	2000	4000
Sound absorption coefficient α_s	0.37	0.70	0.80	0.77	0.82	0.76

Find all our product documentation in many languages, always up-to-date and available at any time, on our website under:
<http://www.vogl-ceilingssystems.com/> in the "Downloads" category

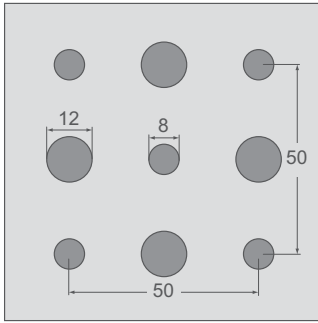

- Determination of sound absorption coefficient as per DIN EN ISO 354
- Rating of sound absorption coefficient as per DIN EN ISO 11654

Panel thickness: $th = 12.5 \text{ mm}$
 Mass per unit area: 8.70 kg/m^2
 Perforated area: 13.1%
 Material class as per DIN 4102: A2, "non-flammable"
 Fire behaviour as per DIN EN 13501: A2-s1, d0

Back of panel laminated with
Acoustic fleece AV 2010

Rated sound absorption $\alpha_w = 0.65$
 sound absorption class **C**
 (highly absorbing)

Single number rating as per ASTM C 423:
 SAA = 0.62
 Classification as per ASTM E 1264:
 NRC = 0.60

Air gap: 200 mm

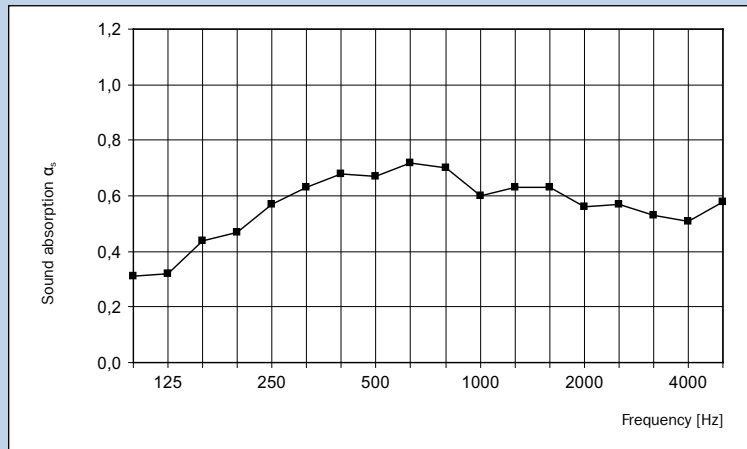

Octave centre frequency [Hz]	125	250	500	1000	2000	4000
Sound absorption coefficient α_s	0.32	0.57	0.67	0.60	0.56	0.51

Back of panel laminated with
Acoustic fleece AV 2010
 backed with glass wool
Mineral wool panel SSP 1, 30 mm

Rated sound absorption $\alpha_w = 0.70$
 sound absorption class **C**
 (highly absorbing)

Single number rating as per ASTM C 423:
 SAA = 0.66
 Classification as per ASTM E 1264:
 NRC = 0.65

Air gap: 200 mm

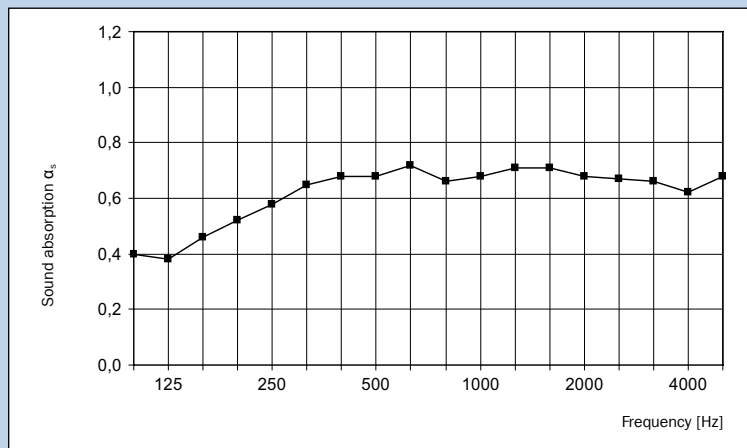

Octave centre frequency [Hz]	125	250	500	1000	2000	4000
Sound absorption coefficient α_s	0.38	0.58	0.68	0.68	0.68	0.62

Find all our product documentation in many languages, always up-to-date and available at any time, on our website under:
<http://www.vogl-ceilingssystems.com/> in the "Downloads" category

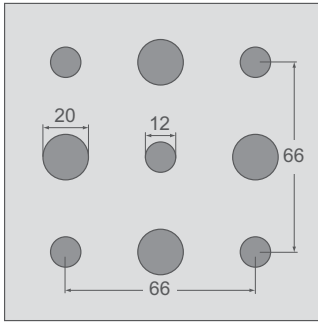

- Determination of sound absorption coefficient as per DIN EN ISO 354
- Rating of sound absorption coefficient as per DIN EN ISO 11654

Panel thickness: $th = 12.5 \text{ mm}$
 Mass per unit area: 8.00 kg/m^2
 Perforated area: 19.6%
 Material class as per DIN 4102: $A2, \text{ "non-inflammable"}$
 Fire behaviour as per DIN EN 13501: $A2-s1, d0$

Back of panel laminated with
Acoustic fleece AV 2010

Rated sound absorption $\alpha_w = 0.70$
 sound absorption class **C**
 (highly absorbing)

Single number rating as per ASTM C 423:
 $SAA = 0.69$
 Classification as per ASTM E 1264:
 $NRC = 0.70$

Air gap: 200 mm

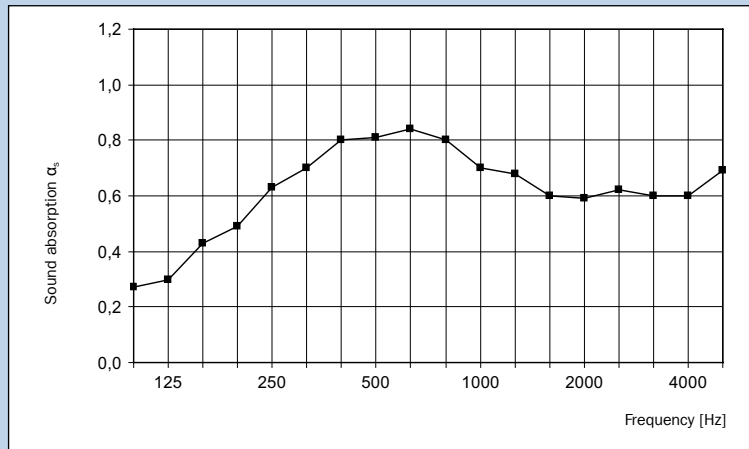

Octave centre frequency [Hz]	125	250	500	1000	2000	4000
Sound absorption coefficient α_s	0.30	0.63	0.81	0.70	0.59	0.60

Back of panel laminated with
Acoustic fleece AV 2010
 backed with glass wool
Mineral wool panel SSP 1, 30 mm

Rated sound absorption $\alpha_w = 0.80$
 sound absorption class **B**
 (extremely absorbing)

Single number rating as per ASTM C 423:
 $SAA = 0.77$
 Classification as per ASTM E 1264:
 $NRC = 0.75$

Air gap: 200 mm

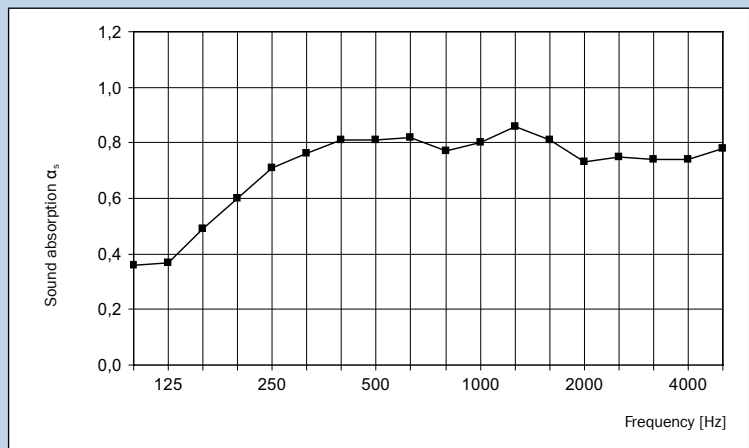

Octave centre frequency [Hz]	125	250	500	1000	2000	4000
Sound absorption coefficient α_s	0.37	0.71	0.81	0.80	0.73	0.74

Find all our product documentation in many languages, always up-to-date and available at any time, on our website under:
<http://www.vogl-ceilingssystems.com/> in the "Downloads" category

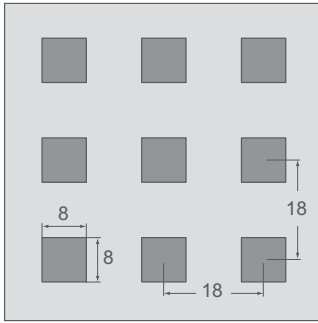

- Determination of sound absorption coefficient as per DIN EN ISO 354
- Rating of sound absorption coefficient as per DIN EN ISO 11654

Panel thickness: $th = 12.5 \text{ mm}$
 Mass per unit area: 8.00 kg/m^2
 Perforated area: 19.8%
 Material class as per DIN 4102: $A2, \text{ "non-inflammable"}$
 Fire behaviour as per DIN EN 13501: $A2-s1, d0$

Back of panel laminated with
Acoustic fleece AV 2010

Rated sound absorption $\alpha_w = 0.75$
 sound absorption class **C**
 (highly absorbing)

Single number rating as per ASTM C 423:
 $SAA = 0.72$
 Classification as per ASTM E 1264:
 $NRC = 0.70$

Air gap: 200 mm

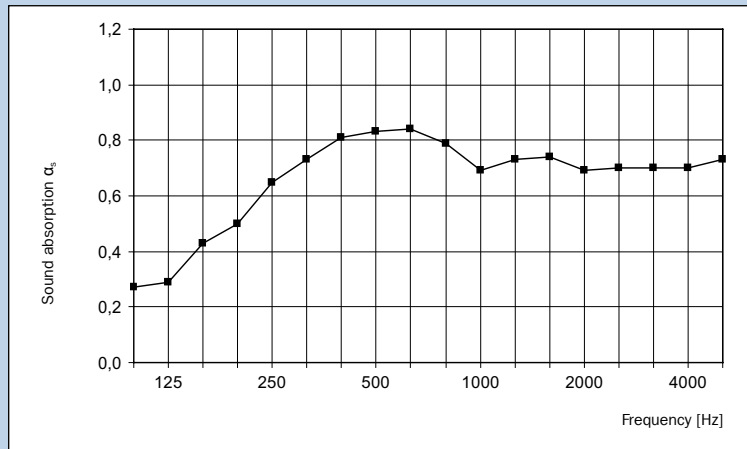

Octave centre frequency [Hz]	125	250	500	1000	2000	4000
Sound absorption coefficient α_s	0.29	0.65	0.83	0.69	0.69	0.70

Back of panel laminated with
Acoustic fleece AV 2010
 backed with glass wool
Mineral wool panel SSP 1, 30 mm

Rated sound absorption $\alpha_w = 0.85$
 sound absorption class **B**
 (extremely absorbing)

Single number rating as per ASTM C 423:
 $SAA = 0.80$
 Classification as per ASTM E 1264:
 $NRC = 0.80$

Air gap: 200 mm

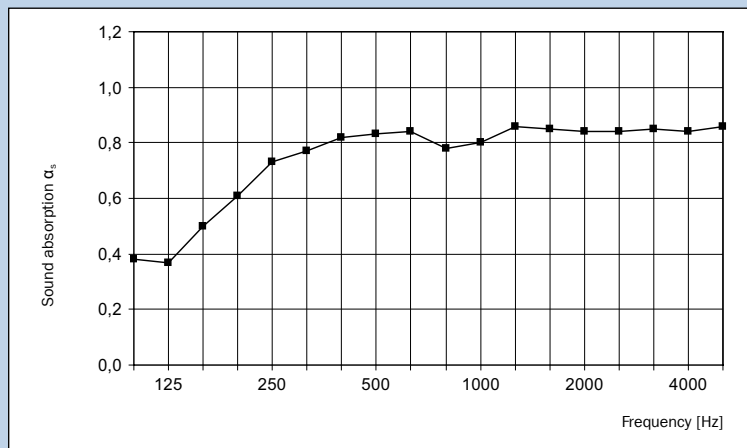

Octave centre frequency [Hz]	125	250	500	1000	2000	4000
Sound absorption coefficient α_s	0.37	0.73	0.83	0.80	0.84	0.84

Find all our product documentation in many languages, always up-to-date and available at any time, on our website under:
<http://www.vogl-ceilingssystems.com/> in the "Downloads" category

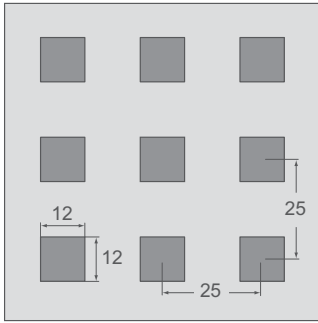

- Determination of sound absorption coefficient as per DIN EN ISO 354
- Rating of sound absorption coefficient as per DIN EN ISO 11654

Panel thickness: $th = 12.5 \text{ mm}$
 Mass per unit area: 7.70 kg/m^2
 Perforated area: 23.0%
 Material class as per DIN 4102: $A2, \text{ "non-inflammable"}$
 Fire behaviour as per DIN EN 13501: $A2-s1, d0$

Back of panel laminated with
Acoustic fleece AV 2010

Rated sound absorption $\alpha_w = 0.75$
 sound absorption class **C**
 (highly absorbing)

Single number rating as per ASTM C 423:
 $SAA = 0.74$
 Classification as per ASTM E 1264:
 $NRC = 0.75$

Air gap: 200 mm

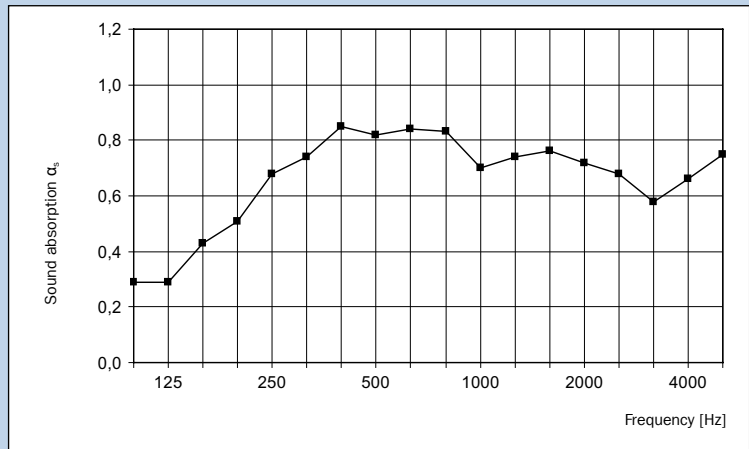

Octave centre frequency [Hz]	125	250	500	1000	2000	4000
Sound absorption coefficient α_s	0.29	0.68	0.82	0.70	0.72	0.66

Back of panel laminated with
Acoustic fleece AV 2010
 backed with glass wool
Mineral wool panel SSP 1, 30 mm

Rated sound absorption $\alpha_w = 0.90$
 sound absorption class **A**
 (extremely absorbing)

Single number rating as per ASTM C 423:
 $SAA = 0.83$
 Classification as per ASTM E 1264:
 $NRC = 0.85$

Air gap: 200 mm

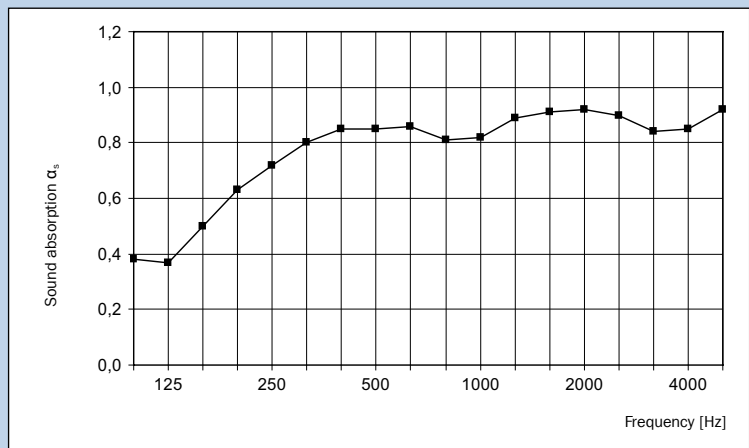

Octave centre frequency [Hz]	125	250	500	1000	2000	4000
Sound absorption coefficient α_s	0.37	0.72	0.85	0.82	0.92	0.85

Find all our product documentation in many languages, always up-to-date and available at any time, on our website under:
<http://www.vogl-ceilingssystems.com/> in the "Downloads" category

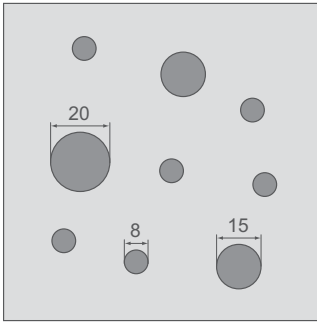

- Determination of sound absorption coefficient as per DIN EN ISO 354
- Rating of sound absorption coefficient as per DIN EN ISO 11654

Panel thickness: $th = 12.5 \text{ mm}$
 Mass per unit area: 9.10 kg/m^2
 Perforated area: 9.5%
 Material class as per DIN 4102: A2, "non-inflammable"
 Fire behaviour as per DIN EN 13501: A2-s1, d0

Back of panel laminated with
Acoustic fleece AV 2010

Rated sound absorption $\alpha_w = 0.55$
 sound absorption class **D**
 (absorbing)

Single number rating as per ASTM C 423:
 SAA = 0.52
 Classification as per ASTM E 1264:
 NRC = 0.50

Air gap: 200 mm

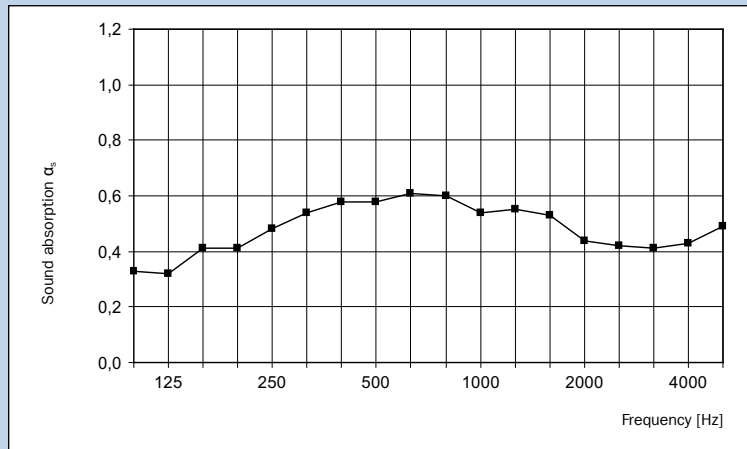

Octave centre frequency [Hz]	125	250	500	1000	2000	4000
Sound absorption coefficient α_s	0.32	0.48	0.58	0.54	0.44	0.43

Back of panel laminated with
Acoustic fleece AV 2010
 backed with glass wool
Mineral wool panel SSP 1, 30 mm

Rated sound absorption $\alpha_w = 0.60$
 sound absorption class **C**
 (highly absorbing)

Single number rating as per ASTM C 423:
 SAA = 0.54
 Classification as per ASTM E 1264:
 NRC = 0.55

Air gap: 200 mm

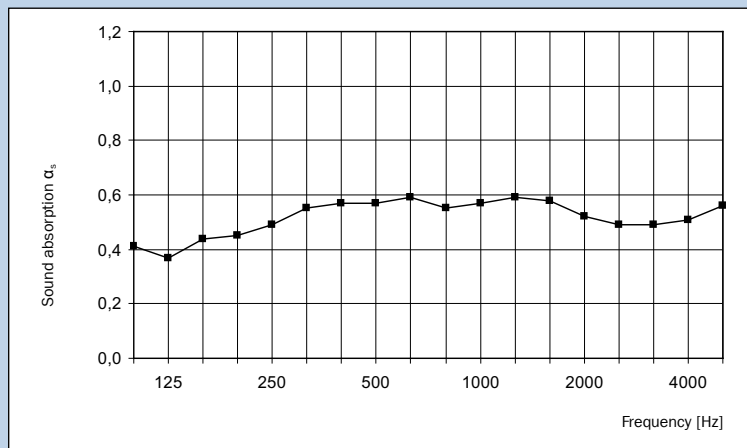

Octave centre frequency [Hz]	125	250	500	1000	2000	4000
Sound absorption coefficient α_s	0.37	0.49	0.57	0.57	0.52	0.51

Find all our product documentation in many languages, always up-to-date and available at any time, on our website under:
<http://www.vogl-ceilingssystems.com/> in the "Downloads" category

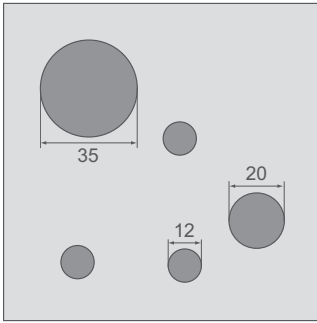

- Determination of sound absorption coefficient as per DIN EN ISO 354
- Rating of sound absorption coefficient as per DIN EN ISO 11654

Panel thickness: $th = 12.5 \text{ mm}$
 Mass per unit area: 8.90 kg/m^2
 Perforated area: 11.0%
 Material class as per DIN 4102: A2, "non-inflammable"
 Fire behaviour as per DIN EN 13501: A2-s1, d0

Back of panel laminated with
Acoustic fleece AV 2010

Rated sound absorption $\alpha_w = 0.55$
 sound absorption class **D**
 (absorbing)

Single number rating as per ASTM C 423:
 SAA = 0.55
 Classification as per ASTM E 1264:
 NRC = 0.55

Air gap: 200 mm

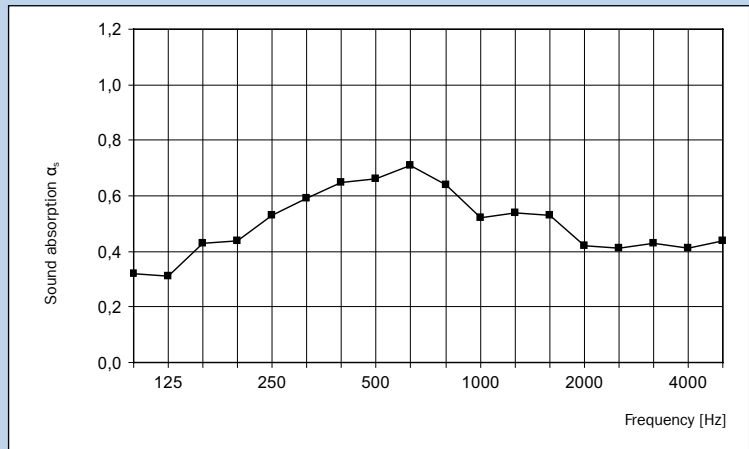

Octave centre frequency [Hz]	125	250	500	1000	2000	4000
Sound absorption coefficient α_s	0.31	0.53	0.66	0.52	0.42	0.41

Back of panel laminated with
Acoustic fleece AV 2010
 backed with glass wool
Mineral wool panel SSP 1, 30 mm

Rated sound absorption $\alpha_w = 0.60$
 sound absorption class **C**
 (highly absorbing)

Single number rating as per ASTM C 423:
 SAA = 0.58
 Classification as per ASTM E 1264:
 NRC = 0.55

Air gap: 200 mm

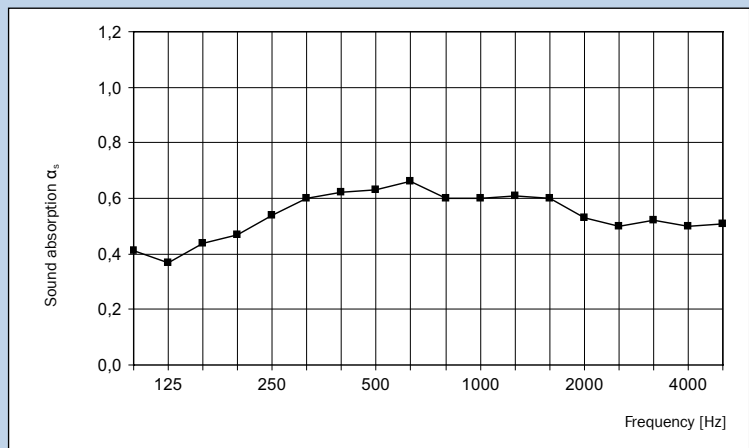

Octave centre frequency [Hz]	125	250	500	1000	2000	4000
Sound absorption coefficient α_s	0.37	0.54	0.63	0.60	0.53	0.50

Find all our product documentation in many languages, always up-to-date and available at any time, on our website under:
<http://www.vogl-ceilingssystems.com/> in the "Downloads" category

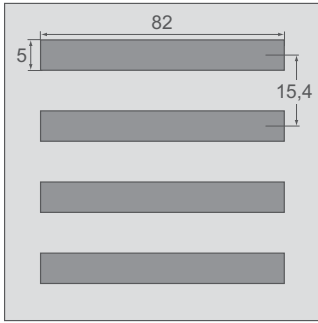

- Determination of sound absorption coefficient as per DIN EN ISO 354
- Rating of sound absorption coefficient as per DIN EN ISO 11654

Panel thickness: $th = 12.5 \text{ mm}$
 Mass per unit area: 7.9 kg/m^2
 Perforated area: 21.5%
 Material class as per DIN 4102: $A2, \text{ "non-inflammable"}$
 Fire behaviour as per DIN EN 13501: $A2-s1, d0$

Back of panel laminated with
Acoustic fleece AV 2010

Rated sound absorption $\alpha_w = 0.70$
 sound absorption class **C**
 (highly absorbing)

Single number rating as per ASTM C 423:
 $SAA = 0.71$
 Classification as per ASTM E 1264:
 $NRC = 0.70$

Air gap: 200 mm

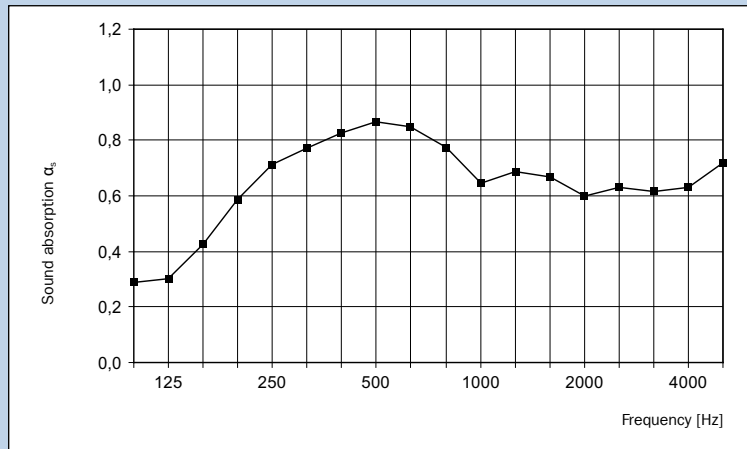

Octave centre frequency [Hz]	125	250	500	1000	2000	4000
Sound absorption coefficient α_s	0.29	0.69	0.86	0.65	0.60	0.63

Back of panel laminated with
Acoustic fleece AV 2010 +
 backed with glass wool
Mineral wool panel SSP 1, 30 mm

Rated sound absorption $\alpha_w = 0.85$
 sound absorption class **B**
 (extremely absorbing)

Single number rating as per ASTM C 423:
 $SAA = 0.83$
 Classification as per ASTM E 1264:
 $NRC = 0.85$

Air gap: 200 mm

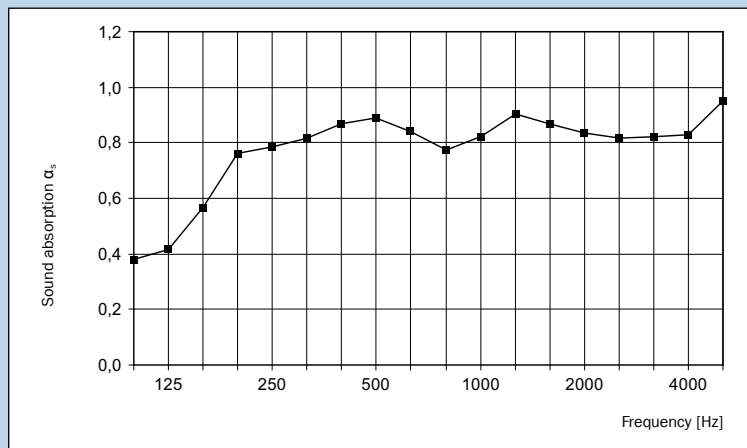

Octave centre frequency [Hz]	125	250	500	1000	2000	4000
Sound absorption coefficient α_s	0.42	0.78	0.88	0.82	0.85	0.83

Find all our product documentation in many languages, always up-to-date and available at any time, on our website under:
<http://www.vogl-ceilingssystems.com/> in the "Downloads" category

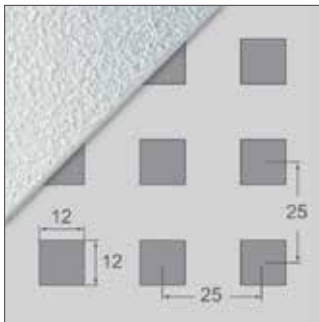

- Determination of sound absorption coefficient as per DIN EN ISO 354
- Rating of sound absorption coefficient as per DIN EN ISO 11654

Panel thickness: $th = 12.5 \text{ mm}$
 Mass per unit area: 7.7 kg/m^2
 Perforated area: 22.9%
 Material class as per DIN 4102: A2, "non-inflammable"
 Fire behaviour as per DIN EN 13501: A2-s1, d0

System structure: wallpapered with plaster base fleece on site and finished with VoglToptec® acoustic plaster Nano SF

Back of panel laminated with
Acoustic fleece AV 2010

Rated sound absorption $\alpha_w = 0.75$
 sound absorption class **C**
 (highly absorbing)

Single number rating as per ASTM C 423:
 SAA = 0.73
 Classification as per ASTM E 1264:
 NRC = 0.70

Air gap: 200 mm

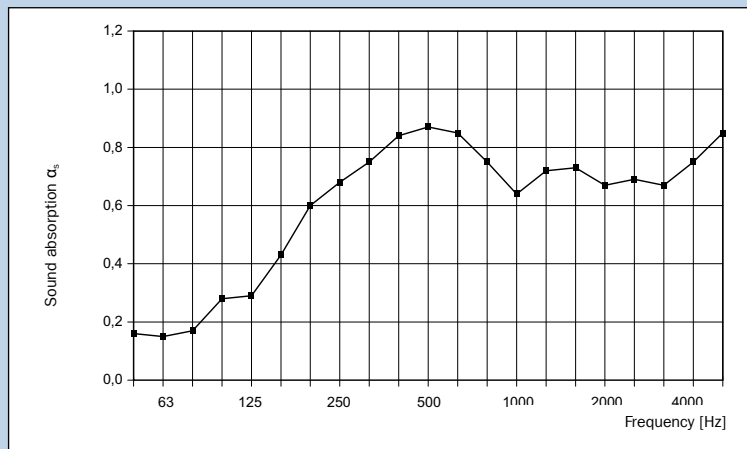

Octave centre frequency [Hz]	125	250	500	1000	2000	4000
Sound absorption coefficient α_s	0.29	0.68	0.87	0.64	0.67	0.75

Back of panel laminated with
Acoustic fleece AV 2010 +
Mineral wool panel SSP 1, 30 mm

Rated sound absorption $\alpha_w = 0.90$
 sound absorption class **A**
 (extremely absorbing)

Single number rating as per ASTM C 423:
 SAA = 0.85
 Classification as per ASTM E 1264:
 NRC = 0.85

Air gap: 200 mm

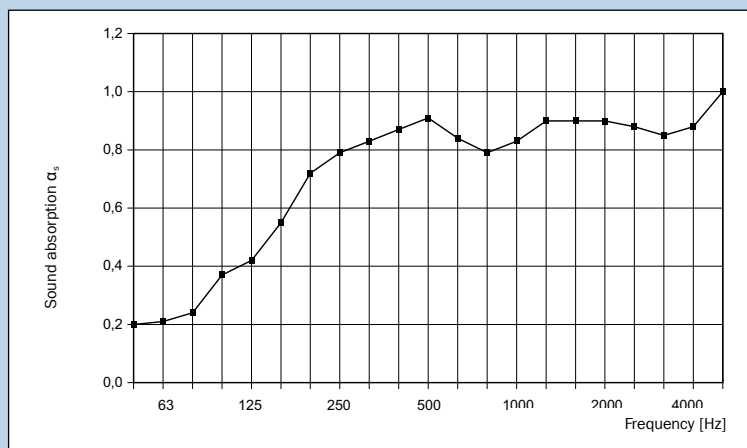

Octave centre frequency [Hz]	125	250	500	1000	2000	4000
Sound absorption coefficient α_s	0.42	0.79	0.91	0.83	0.90	0.88

Find all our product documentation in many languages, always up-to-date and available at any time, on our website under:
<http://www.vogl-ceilingssystems.com/> in the "Downloads" category

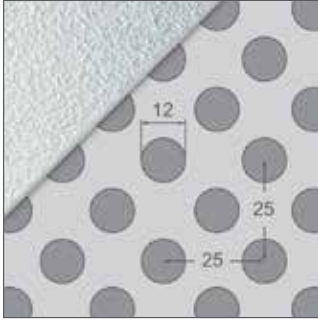

- Determination of sound absorption coefficient as per DIN EN ISO 354
- Rating of sound absorption coefficient as per DIN EN ISO 11654

Panel thickness: $th = 12.5 \text{ mm}$
 Mass per unit area: 6.5 kg/m^2
 Perforated area: 35.3%
 Material class as per DIN 4102: A2, "non-inflammable"
 Fire behaviour as per DIN EN 13501: A2-s1, d0

System structure: wallpapered with plaster base fleece on site and finished with VoglToptec® acoustic plaster Nano SF

Back of panel laminated with
Acoustic fleece AV 2010

Rated sound absorption $\alpha_w = 0.80$
 sound absorption class **B**
 (extremely absorbing)

Single number rating as per ASTM C 423:
 SAA = 0.75
 Classification as per ASTM E 1264:
 NRC = 0.75

Air gap: 200 mm

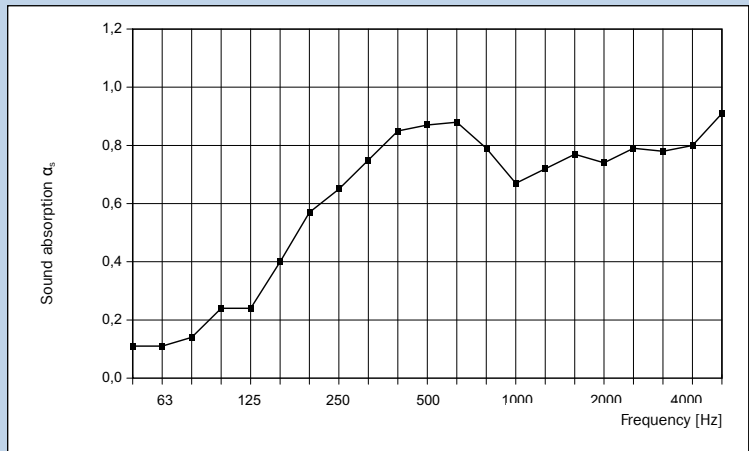

Octave centre frequency [Hz]	125	250	500	1000	2000	4000
Sound absorption coefficient α_s	0.24	0.65	0.87	0.67	0.74	0.80

Back of panel laminated with
**Acoustic fleece AV 2010 +
 Mineral wool panel SSP 1, 30 mm**

Rated sound absorption $\alpha_w = 0.95$
 sound absorption class **A**
 (extremely absorbing)

Single number rating as per ASTM C 423:
 SAA = 0.91
 Classification as per ASTM E 1264:
 NRC = 0.90

Air gap: 200 mm

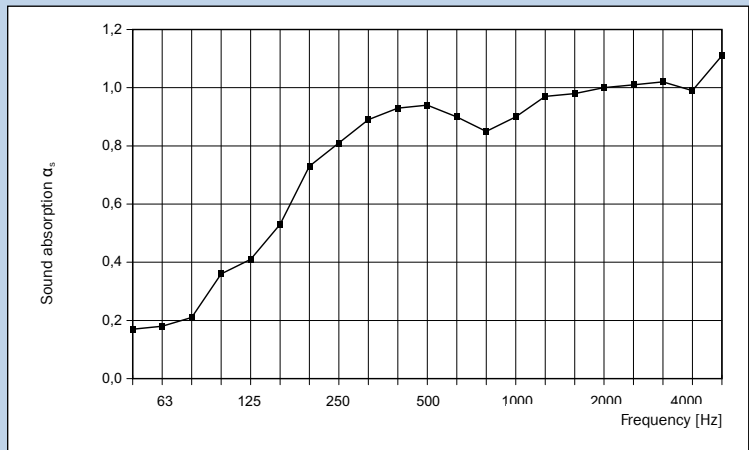

Octave centre frequency [Hz]	125	250	500	1000	2000	4000
Sound absorption coefficient α_s	0.41	0.81	0.94	0.90	1.00	0.99

Find all our product documentation in many languages, always up-to-date and available at any time, on our website under:
<http://www.vogl-ceilingssystems.com/> in the "Downloads" category

VOGL System Training

Our know-how for your result reliability



Inquiry

Vogl Deckensysteme GmbH · Ms Jessica Sauchella · Industriestrasse 10 · D-91448 Emskirchen

I am interested in the following event:

- Acoustic plaster system VoglToptec® – Applications and processing
- Framework for acoustic design ceilings ("perforated ceilings")
- Installation of acoustic design ceilings – Various joint systems
- Others _____

Personal data

Date / stamp / signature

Company	Contact partner
Street, house no.	Postcode, town/city
Phone	E-mail

Having a long journey, I would like to arrive the day before the training course and require accommodation for one night. Please send me some hotel addresses with your special rates.

Some more colleagues/customers are interested. I expect to come with people.

We are looking forward to your visit in Emskirchen! (Emskirchen is located 25 km to the northwest of Nuremberg)

You have any questions in advance? We are glad to assist you! Phone: 09104-825-100

Registration is possible by e-mailing sauchella@vogl-deckensysteme.de directly or by fax to 09104/825-280. You can also find all information on training under www.vogl-ceilingssystems.com

A

Abrasive mesh	54
Access panels (general)	147
Acoustic floating ceilings	41
Acoustics and sound absorption	161
Additional charges	58
Adjustable vibration bracket	17
Advantages, Access panels	148
Advantages, Ball-impact resistant ceiling	102
Advantages of the Compound Seam	92
Advantages, Vogl Frieze Tape Set	158
Advantages, VoglToptec®	118
Anchor bracket	17
Anchor fast suspension	16
Anchor suspension	16
Angled connector	18

B

Ball-impact resistant ceiling (general)	101
Bucket trowel	55

C

CD profile	15
Ceiling Tiles (general)	109
Chamfer plane	54
Chapter Overview	03
Compound Seam (general)	91
Connection pliers	54
Connector	18, 24
Cooling and heating ceilings	31
Cross connector	17
Custom models, VoglToptec®	123

D

Direct mounting clip	16
Direct mounting vibration clip	20
Direct suspended bracket	16
Direct vibration hanger	20
Double spring clip	22
Drilling template	56
Drywall saw	55
Drywall screw	25

E

Easy-span hanger	22
Editorial	06
Europallets	58
Eyelet wire	19, 21

F

Fastening clip	16
Framework, Ball-impact resistant ceiling	105
Framework, Compound Seam	94
Framework for GSG4 joint	84
Framework, VoglToptec®	121

G

General Terms and Conditions	182
GSG4 Joint, advantages	80
GSG4 Joint (general)	79
GSG4 Joint, installation guide	86
GSG4 Joint, perforation patterns	82
GSG4 Joint, special designs	83

H

Handle with knurled screw	55
Hand sander	54
Hooked wire	22

I

Installation guide, access panels	149
Installation guide, Ceiling Tiles	116
Installation Guide, Compound Seam	96
Installation guide, VoglFriestape-Set®	159
Installation guide, VoglToptec®	124
Interseroh	58

J

Joint sealing set	55
-------------------	----

M

Mounting aid	56
--------------	----

P

Panel pallet	58
Parcel service charges	58
Perforated panel screw	25
Perforation wheel	55
Philosophy	07
Picture Gallery	04
Plastic foil hood	58
Product portfolio	09
Product Range, 3D design	49
Product Range, Adhesive seam	30
Product Range, Ball-impact resistant ceiling	103
Product Range, Ceiling tiles	36
Product Range, Compound Seam	27, 93
Product Range, Double layer fleece	54
Product Range, GSG4 joint	28, 81

Index

Product Range, Moulded components	42, 142
Product Range, Stretch ceilings	53
Product Range, Visible chamfer	29
Product Range, Vogl access panels	50
Product Range, VoglFriestape-Set®	54
Product Range, VoglFuge®	26
Product Range, VoglModu® QuadRound	52
Product Range, VoglThermotecplatten® Compound Seam ...	32
Product Range, VoglThermotecplatten® PLUS Compound Seam	34
Product Range, VoglThermotecplatten® PLUS VoglFuge	33
Product Range, VoglThermotecplatten® VoglFuge®	31
Product Range, VoglToptec®	40, 119
Product Range, Working methods	54
Products	11

Q

Quick hanger	22, 24
--------------------	--------

R

Recycling certificate	58
Rentex	53
Replacement blades for chamfer plane	54
Round rasp	55

S

Sanding paper	54
Screwdriver handle trowel	55
Screw head trowel	55
Service portfolio	10
Services	58
Shipping costs	58
Sound absorption values	161
Sound absorption values, acoustic design panel ...	162
Sound absorption values, acoustic plaster system panel	174
Sound absorption values, ultracoustic panel	175
Spare parts for joint sealing set	55
Special palletising	58
Support clip	17
Surcharge	58
System components, VoglToptec®	120
System description, Ball-impact resistant ceiling ...	106
System Description, Compound Seam	95
System description, VoglToptec®	122
System structure, Ceiling Tiles	114

T

3D Design (general)	145
Tapping screw	25
Tender specification, Ball-impact resistant ceiling ...	108
Tender specification, Compound Seam	99

Tender specifications (general)	181
Tender specification, VoglFriestape-Set®	160
Tender specification, VoglToptec®	128
Twisting anchor bracket	17

U

UA cross connector	17
UD profile	15
Universal connector	18
Universal mixing paddle	55
Unloading costs	58

V

Vernier bottom part	20
Vernier connector	19
Vernier coupling	20
Vernier hanger	20
Vernier rod	20
Vernier safety bolt	19
Vernier short hanger	23
Vernier suspended bracket	23, 24
Vernier top part	19, 21
Vertical connector	18
Vogl ceiling paint Colormix Plus	57
Vogl ceiling paint White Premium	57
VoglColorplatte®	35
VoglFriestape-Set® (general)	157
VoglModu® QuadRound (general)	150
Vogl Stretch Ceiling (general)	151
Vogl Supergrund primer	56
VOGL System Training, Acoustic plaster system	
VoglToptec® – Applications and processing	140
VOGL System Training, inquiry	176
VOGL System Training, topic: Framework for acoustic design ceilings	90
Vogl System Training, topic: Installation of acoustic design ceilings – various joint systems	100
VoglToptec® Akustik Color Nano SF	57
VoglToptec® Akustik Nano SF	57
VoglToptec® (general)	117
VoglToptec® plaster base fleece	57
VoglToptec® plaster base fleece, small	57
VoglToptec® special adhesive	57
VoglToptec® wallpaper smoother	57

W

Wafer head screw	25
------------------------	----

Tender Specifications



Use our multiple online resources:

- References
- Videos
- Acoustic calculator
- Picture gallery
- Flyers
- Newsletter
- Detailed designs
- Specifications
- Installation guides as PDF and animated



Online support, making your job easier:
www.vogl-ceilingssystems.com



General Terms and Conditions

§ 1 General

All contracts, deliveries and services are regulated exclusively by our following General Terms and Conditions. They apply particularly with regard to merchants and companies as well as for all future business relationships without the need for explicit repeated reference thereto.

Any contradictory General Terms and Conditions, in particular the customer's Conditions of Purchase, are only valid if confirmed by us.

§ 2 Offer and Acceptance, Service Description

Our offers are non-binding.

The acceptance of a still valid offer leads to a binding order once confirmed by us in writing.

Our written confirmation of the order is exclusively relevant for the terms of the contract. Technical data and descriptions in our product information or marketing materials do not constitute a guaranty of quality or durability and particularly do not guarantee any specific properties.

In case of sample-based sales, the Purchaser shall inspect the Goods immediately and report any complaints within a period of ten days. After this period has expired, the sample or specimen is deemed to be accepted and the desired contractual relationship comes into effect.

For custom-made goods, the right to withdraw from the contract is excluded. Customised orders are only realised when the technical requirements put forth by the Purchaser are unambiguous and feasible and are confirmed by us in writing.

Models and tools remain our property, even when the customer has paid for their construction.

§ 3 Prices, Terms of Payment and Default

The prices specified in the respective contract, particularly in the order form or the order confirmation, are valid plus statutory VAT (value added tax). If a price is not explicitly defined, our respective price lists at the time of the contract are valid. The weights and quantities defined by us determine the calculation of the prices unless the Purchaser objects immediately upon receipt of the Goods and proves the contrary. Packaging and transportation costs, and any costs of transportation insurance, are charged in addition.

We reserve the right to also adjust our prices after conclusion of the contract in case significant unforeseen changes in costs occur, e.g. through exchange rate fluctuations.

Unless otherwise agreed, our invoices are payable within 30 days of receipt. After this period has expired, the Purchaser is automatically in default and has to pay interest from then on in the amount of currently five percentage points above the base rate of the European Central Bank. Discounts are only given if separately agreed upon. The final invoice amount minus shipping costs, packaging costs and palette value are discountable. If circumstances become known that give rise to justifiable doubt about the Purchaser's ability to pay, we have the right to freely choose to either withdraw from the contract or to demand prepayments or securities for receivables due or not yet due from the entire business relationship, and to make the obligation to deliver dependent on the provision of such securities.

§ 4 Transportation, Transfer of Risk, Place of Fulfilment

Place of fulfilment is our business location in Emskirchen. The transfer of risk takes place as soon as the Goods have been loaded into the means of transport or, in case of collection, as soon as we have expressed readiness for dispatch in writing.

Transportation of goods takes place exclusively and in all cases at the Purchaser's risk, even if the delivery is carried out by us, be it with one of our own lorries or freight carriers or other commissioned third parties.

§ 5 Packaging

We charge for the pallets used for shipping. If the pallets are returned carriage paid in undamaged condition, we will accredit the same amount. If the goods are packaged in a different way than the usual standard based on the customer's wishes, these packaging costs will be charged separately.

§ 6 Time of Delivery and Performance

We generally do our best to meet agreed delivery dates, with the notification of readiness for dispatch qualifying as fulfilment of the delivery date.

In case of force majeure and other unforeseeable circumstances beyond our control, particularly operational disruptions through fire, water and damage to production facilities and machinery caused thereby, non-delivery by our suppliers, disruptions due to lack of raw materials, power failure, strikes or lockouts, traffic disruptions or interventions by the authorities, the delivery time will be extended appropriately.

If the delivery is postponed by more than a month, both we and the Purchaser have the right to withdraw from the contract with any claims for damages being excluded. In case of a performance default caused by us, the Purchaser has the right to withdraw if the delivery of Goods fails to take place within a reasonable grace period.

The amount of any resulting claim for damages is limited to the order value.

§ 7 Purchaser Rights and Obligations, Retention of Ownership and Prohibition of Assignment

The Purchaser undertakes to collect the Goods declared ready for dispatch immediately and to pay within the term of payment in compliance with article 3. The Purchaser undertakes to immediately check the Goods for defects and to report any defects detected.

The delivered Goods remain our property up to the full payment of all invoices currently due under the business relationship and shall thus be treated with care by the Purchaser and shall be sufficiently insured at replacement value, particularly against loss, damage and destruction as well as against theft, at the Purchaser's expense. The Purchaser assigns any claims arising from insurance policies to us, and we accept this assignment.

For enforcing these claims, the Purchaser has to provide address and membership number for the respective insurance. The Purchaser is not permitted to pledge the Goods in our ownership nor to transfer title to the Goods by way of security. Processing of the Goods prior to payment is only allowed upon our express prior consent.

Any claims resulting from a resale of the Goods delivered by us are assigned to us, and we accept this assignment. For enforcing these claims, the Purchaser has to provide name and address of his customer.

Attachments and any other third-party interventions shall be brought to our attention immediately so that we can exercise our rights arising from the reservation of title.

Even through processing, Goods under our retention of title do not become the property or the co-property of the Purchaser.

§ 8 Warranty and Compensation

We are obligated by the contract to provide the Goods free from material defects and defects of title. The Goods are free from defects when they possess the agreed quality or are suitable for common use and have a quality that is usual amongst goods of the same nature and that can be expected by the Purchaser from this type of goods. If the Goods do not have these properties, the Purchaser can expect subsequent fulfilment provided that he has complied with his obligation of immediate inspection and notification of defects. It is our decision whether we remedy or deliver replacement Goods.

If this is impossible or too expensive, i.e. possible only on the basis of disproportionately high costs, we can refuse subsequent fulfilment. In this case, the Purchaser may withdraw from the contract or, if he keeps the defective Goods, demand an appropriate price discount.

Here, the value of the goods in a state free of defects and the significance of the defect for the fulfilment of the contractually intended results need to be specifically taken into consideration. Exercising claims for damages is excluded.

If the Purchaser withdraws from the contract without any justifying cause, he has to pay lump-sum damages of 30% of the value of the goods due to breach of contract unless the Purchaser can prove a minor damage. If our damage is verifiably larger, we may demand higher compensation of damages.

§ 9 Time of Limitation for Claims

Purchaser claims due to defects of the goods delivered by us or for services rendered in breach of our duty, including compensation claims and claims for replacement of futile expenditures, expire a year after delivery. Exempted from this are claims for damages according to the product liability law and damages in context with the lack of assured properties; these claims expire three years after delivery.

§ 10 Place of Jurisdiction, Applicable Law

Exclusive place of jurisdiction for all claims resulting from the contractual agreement is the jurisdiction of the place of fulfilment, which in this case is either the county court of Neustadt/Aisch or the regional court Nuremberg-Fuerth. The law of the Federal Republic of Germany is exclusively applicable; the regulations about the international purchase of goods and of international civil law are expressly excluded.

§ 11 Technical Consulting, Information, Training

Our technical information, suggestions and consultative services are only binding if they are carried out in relation to a specific project and in writing.

Furthermore, our specifications and guidelines related to the technical implementations apply.

§ 12 Final Clause, Severability Clause

Additional oral agreements besides the written contracts have not been made. Any changes and amendments require the written form.

If any of the preceding provisions should be totally or partially ineffective, this shall not affect the validity of the remaining provisions.

The ineffective provisions shall be interpreted in good faith and with the interests of the parties in mind in such a way that they come as close as possible to the permissible provisions.



Vogl Deckensysteme GmbH

Industriestrasse 10
D-91448 Emskirchen

Phone +49 (0) 9104-825-0
Fax +49 (0) 9104-825-250

info@vogl-ceilingystems.de
www.vogl-ceilingystems.com

Subject to technical changes. Consumption, quantity and design details are based on empirical values. The details contained in this text correspond to the current state of technology. Any relevant valid building technology regulations, standards and guidelines must be observed in addition to our processing instructions. All rights reserved. Reprints as well as electronic reproduction, even extracts, require the express approval of Vogl Deckensysteme GmbH, Industriestrasse 10, 91448 Emskirchen, Germany. 01/15



Vogl Deckensysteme GmbH

Industriestrasse 10
D-91448 Emskirchen

Phone +49 (0) 9104-825-0
Fax +49 (0) 9104-825-250

info@vogel-ceilingssystems.de
www.vogel-ceilingssystems.com

